

Architectural Binder Section NW Reinforced 647

GENERATION ™

Folding Glass Walls by NanaWall

NanaWall[®]
Boundaries **Unbound**[®]

Nana Wall Systems, Inc.
100 Meadowcreek Drive #250
Corte Madera, CA 94925

800 873 5673
415 383 3148
Fax 415 383 0312

info@nanawall.com
nanawall.com

r4-0324

NW Reinforced 647—Generation 4 Folding Glass Wall by NanaWall for Mid-Rise Multifamily Buildings

NW Reinforced 647 is a Generation 4 folding glass wall system specifically designed for mid-rise buildings where higher windload requirements and limits to deflection are needed. Designed to meet the structural capabilities required for taller buildings with a DP rating of +/-70 psf in accordance with (ASD) Allowable Stress Design Pressure, the reinforced frame profile is styled in a crisp, angular design where the intersection of two folding panels is a mere 5 1/4" (133 mm). Comprised of a host of proprietary and patented features, this Generation 4 Folding Glass Wall by NanaWall offers a streamlined appearance with minimal exposed hardware, creating a new level of aesthetics.

With floor supported panels capable of reaching system heights up to 10' 2" (3100 mm) and panel widths up to 3' 3" (1000 mm), this folding glass wall offers the possibility of wider opening sizes with the integration of FourFold and SixFold Panel Sets that move and stack to either side of the opening. NW Reinforced 647 provides the ultimate in layout flexibility. For openings onto balconies, terraces, and rooftops, this reinforced folding glass wall system opens wide to 90% or more and is not restricted as with a traditional slider.

A swing door is possible for easy access and unlike a multi-track slider, the single track sill is slim and clean with options to meet ADA compliance.

As a performance-driven architectural solution, this system is independently certified and rated to meet CW-PG35. Available in inswing or outswing configurations, NW Reinforced 647 provides fresh air, increased daylight, and expanded living to the outdoors in a vertical living environment.

Designed for energy efficiency and strong weather performance, this folding glass wall provides exceptional protection from outside elements and delivers comfort and security when closed. As a NanaWall product, the NW Reinforced 647 has been put through rigorous independent performance testing for air, water, structural, operation, and forced entry with excellent results.

Minimal Sightline for a Modern Aesthetic

Panel frames are slim and contemporary with a total 5 3/16" (133 mm) junction where the two adjacent folding vertical stiles meet. The panel profiles offer a crisp, angular design. Top and bottom rails are a minimal 2 5/8" (67 mm), providing slim-line aesthetics. Panel depth is 2 5/8" (67 mm).

To coordinate with design programs, simulated divided lites, horizontal and vertical mullions are possible.

Patented Multifunctional Thermal Break Affords Slim Sightline

The Bionic Turtle® is a patented (Patent No. US10550625B2) polyamide single piece insulbar design that serves many functions. Not only does it provide an outstanding insulating thermal break within the frame profiles for energy efficiency, but it also serves as a concealed channel to house the system's locking rods. By being able to combine functions within one element, the Bionic Turtle design allows the slim profile appearance of NW Reinforced 647.

Unique Gothic Arch Roller Design Provides Frictionless Smooth Operation

NW Reinforced 647 is engineered for ease of use. Hinged panels are intuitive and convenient to operate allowing for the effortless opening and closing of the system on demand. The bottom rollers run on two stainless steel wheels with a unique Gothic arch design supported by a double row of encapsulated and self-lubricating ball bearings. With a 2-point contact of each wheel to the floor track, the system glides quietly and smoothly with less friction by providing an equal distribution of weight on the stainless steel track.

The rollers run above the water table, visible during operation and concealed between the panel profiles when the system is closed. This proprietary design allows for continued long-term smooth operation and has been (internally) tested to 20,000 opening and closing cycles in accordance with DIN/EN 1191.

Left/Right FourFold or SixFold Panel Set Available for Wider Openings and Flexible Stacking

NW Reinforced 647, along with Generation 4 Folding Glass Walls by NanaWall product family, is the only floor supported, thermally broken folding systems available that allows for larger opening sizes and flexible space management with the integration of up to one unhinged FourFold or SixFold Panel Set in a unit. These panel sets are able to move and stack either to the right, left, or center within the same track allowing the panels to be stacked in the most convenient location as needed. Additionally, the panels may be partially opened and located to control traffic flow or utilized to protect areas that are exposed to excessive wind.

Floor Supported Technology Reduces Structural Requirements

Floor supported systems are ideal for applications where the load-bearing capability of the header is a concern.

The benefits of floor supported are:

Reduced Structural Requirements

- Control construction costs. NanaWall Floor Supported Technology requires less header load and limits the need for extensive pre-cambering.
- Improves the likelihood of keeping existing header when retrofitting/remodeling thus reduced construction costs—as long as the maximum deflection is the lesser of a 1/4" or L/720.

Long-term Durability and Smooth Operation

- Floor supported systems are durable and offer smooth operation with stainless steel wheels on a stainless steel track.

Three Sill Options with High Heel Resistant Feature

NW Reinforced 647 has three sill options: Performance, Low Profile Saddle, and Low Profile Saddle with UniverSILL® (Patent No. US011174673B2). Standard to all sills is removable aluminum high heel resistant sill inserts. These inserts provide ADA compliance for the Low Profile Saddle sill and create a very barefoot-friendly transition. Furthermore, the inserts offer protection from dirt and debris collecting in the bottom track. A lighted option is possible; LED rope lights by others may be run under the sill insert to illuminate the way.

Swing Doors for Traffic Management

To accommodate traffic flow, swing panels can be added either to the end of a chain of panels for systems with an odd number of panels folding in one direction or hinged to the side jamb (up to 3' 3" (1000 mm)), depending on unit height and configuration.

Swing panels have been tested and passed over 500,000 cycles and can be optionally outfitted with higher kickplates for ADA compliance. Top door closer by others is possible.

A single, stand alone swing door hinged to the jamb is offered up to 3' 7" (1100 mm).

Please reference the NW Reinforced 647 size charts.

Concealed Panel Alignment Means Less Exposed Panel Hinges

The patented (Patent No. US10711510B2) TwinX mechanism aligns panels of over 7' (2150 mm) in height by adding a hidden

spring-loaded structural reinforcement feature without the need for an additional exposed hinge in the middle of the system. TwinX interlocks the panels together when the system is closed providing a consistent seal between the panels, specifically engineered to meet higher wind loads. This unique feature provides a clean-lined, sleek, and uniform appearance to the system.

Multipurpose Frame Insert Provides Continuous Surface at Side Jamb and Head Track

Standard to the system is a black polyamide clip-on multipurpose frame insert that conceals all visible frame-to-structure attachment points and screw heads to create a clean, even appearance. Additionally, this frame cover piece creates a hollow space to run and guide concealed cabling for the NW Reinforced 647 to connect to a home security system by others.

System Width Adjustment Feature for Long-term Tight, Consistent Sealing

System width adjusts with ease. To allow for construction tolerance, a patented (Patent No. US10683688B2) lateral adjustment feature of +/- 3/16" (5 mm) is available at the side jamb. This allows for consistent seal compression within the system and can be adjusted should the need arise. This adjustment feature is located so that it doesn't interfere with the continuous perimeter seal of the frame.

Anti-tilt Feature For Dynamic Stacking of Panel Sets

Each floor supported FourFold or SixFold Panel Set is outfitted with a proprietary engineered anti-tilt feature in the head track. This feature assures that the floating panels stack neatly and securely when in open formation. Panels may stack either to the right side, left side, or anywhere within the opening.

Installation Mounting Plate for Optimal Load Transfer

Stainless steel installation plates provide optimal load transfer reducing the number of screws required for mounting the system's frame. Each installation plate is backed with a sealing cushion to avoid bridging the thermal break and spreads the load of the screw head over a larger surface area resulting in fewer fixing points needed. These plates create a clean, finished look.

Optional Advanced Security Mechanism

For applications requiring state-of-the-art security, an optional lock monitoring system with Reed contacts is

available located within the head track. A special concealed locking mechanism end cap, in combination with the concealed Reed contact, creates an open or closed loop for the home security system supplied by others. This optional locking feature can be concealed cable routed through the frames to a home security system. Additionally, the Reed contact can be connected to a service/maintenance system by others that counts the number of opening and closing cycles of the unit advising when it may be time to contact a service technician for routine maintenance.

Concealed Locking for Clean Appearance

Concealed locking between folding panels that operates with a 180° turn of a flat handle. Standard to NW Reinforced 647 is the PowerLock—a pair of locking bolts to the top and to the bottom with approximately a 1" (24 mm) throw for maximum security engagement into the head and floor track.

Standard and Tested Locking Option on Primary Swing Panels:

1. Multi-point locking operated by lever handles and with European profile cylinder. Locking is independently tested for air, water, structural load performance, and forced entry. Instead of a profile cylinder, an adapter case is available for use with an SFIC core.

Non-standard Commercial Locking Options on Primary Swing Panels (no air, water, or structural load values for primary swing panel):

1. Deadbolt lock(s) and push/pull handles and key/key European profile cylinder on both sides. Only recommended for end swing panel with door closer by others. Instead of a profile cylinder, an adapter casing is available for use with an SFIC core.

Standard and Tested Locking for Secondary Swing Panels:

1. Concealed edge lock with top and bottom locking bolts have approximately a 1" (24 mm) throw for maximum security engagement into the head and floor track. Locking is independently tested for air, water, structural load performance, and forced entry.

For additional hardware options, contact NanaWall.

Handles

Stainless Steel Lever Handles

Stainless steel lever handles and escutcheon plates are available either in brushed satin or black titanium finish.

Stainless Steel Flat Handles

Stainless steel flat handles are available either in brushed satin or black titanium finish.

Spring-Loaded Pull Handle

For outswing units with larger panel sizes, a spring-loaded pull handle is supplied for ease of closing the system.

The pull handle is located above the flat handle. When not in use, the handle lays flat against the adjacent panel and is supplied with bumpers to avoid metal-to-metal contact.

Handles are either silver or black titanium stainless steel with the attachment to coordinate with the hinge hardware of the system.

System Sizes

Depending on the desired glazing of the unit, maximum panel sizes range. For double or triple glazed systems, units can reach heights of 10' 2" (3100 mm) and panel widths up to 3' 3" (1000 mm). Increased system widths are possible with the addition of unhinged FourFold or SixFold Panel Sets.

Thermal Efficiency and Glazing Options

A fundamental benefit of this Generation 4 folding glass wall is energy efficiency. Depending on glass type selected, NW Reinforced 647 offers thermal performance values as low as ".24". The system comes standard with continuous seals along the face of each panel frame. Furthermore, standard for each system are two levels of insulating thermal breaks for optimal defense from heat and cold.

The glass pocket can accommodate glass from 1/4" (6 mm) to 1 3/4" (45 mm) insulated glass.

Florida Product Approval

NW Reinforced 647 for all panel sizes and configurations is Florida statewide approved with Product Approval number FL41109. This approval includes inswing, outswing, and cornerless units.

Finishes

NW Reinforced 647 is available in 50 standard powder coat colors in standard AAMA 2604 (2605 optional) and over another 200 optional colors available in powder coat and anodized finishes. Custom matched colors and simulated wood effects are also available. For accurate color swatch examples, please request our Powder Coating Finish Options brochure.

Performance Sill NW Reinforced 647

TYPE OF TEST	INWARD OPENING UNITS	OUTWARD OPENING UNITS	
 Air Infiltration ^① ASTM E-283, ft ³ /min./ft. and NFRC 400	@ 1.57 psf (75 Pa): 0.03 (0.03 exfiltration) A3 ^②	@ 1.57 psf (75 Pa): 0.03 (0.03 exfiltration) A3 ^②	
	@ 6.24 psf (300 Pa): 0.07	@ 6.24 psf (300 Pa): 0.07	
 Water Penetration ^{①*} ASTM E-547 and E-331	No uncontrolled water entry ^① @ 9 psf (450 Pa) Please contact NanaWall for more information when higher water ratings are necessary.		
 Structural Load ^① ASTM E-330; pass See design windload charts for other sized panels <i>Note that the structural test pressures were 50% higher than the design pressures shown.</i>	DESIGN PRESSURE		
	Positive @ 70 psf (3330 Pa)	Negative @ 70 psf (3330 Pa)	Positive @ 70 psf (3330 Pa)
	Uniform Load Deflection, L/175 @ 35 psf (1700 Pa) Class CW-PG35 - FLD 4000 x 2600 & Class LC-PG60 - FLD 4000 x 2600		Negative @ 70 psf (3330 Pa)
Uniform Load Deflection, L/175 @ 35 psf (1700 Pa) Class CW-PG35 - FLD 4000 x 2600 & Class LC-PG60 - FLD 4000 x 2600		Uniform Load Deflection, L/175 @ 35 psf (1700 Pa) Class CW-PG35 - FLD 4000 x 2600 & Class LC-PG60 - FLD 4000 x 2600	
 Forced Entry Resistance ^① AAMA-1304	In accordance with AAMA-1304 requirements		
 Operating Force ^① ASTM E-2068	The NW Reinforced 647 meets <ul style="list-style-type: none"> • Swing Panel: Open 1 lbf (2.8 N) & Close 1 lbf (3.9 N) • Folding Panels: Initiate Motion - Open 4 lbf (20 N) & Close 3 lbf (15 N) • Folding Panels: Maintain Motion - Open 1 lbf (3 N) & Close 1 lbf (4 N) 		
 Operation / Cycling Performance AAMA 920 & DIN EN 1191 Windows and Pedestrian Doors - Mechanical Durability	The NW Reinforced 647 meets: <ul style="list-style-type: none"> • "AAMA 920" requirement for swing panel attached to side jamb: 500,000 cycles - Pass • German "DIN EN 1191/12400 Classification," where a unit is tested after 20,000 opening and closing cycles and is still functional 		

① Excerpts of results of 13' 1" W x 8' 6" H (4000 mm x 2600 mm) 4 panel unit (1L3R configuration) specific or equivalent to lab tested by Intertek Building & Construction, an independent testing laboratory in March 2020 per AAMA/WDMA/CSA 101/IS.2/A440-17, NAFS-17 - North American Fenestration Standard

② For Canada, tested to NAFS-17 or equivalent and CSA A44051-09 (for drainage of standing water, weep hole in sill by others).

* Water and structural ratings may not be applicable for configuration not tested, especially even panels plus even panels configurations.



Thermal Performance

NW Reinforced 647[®] - Rated, certified, and labeled in accordance with NFRC 100 + 200

TYPE OF GLASS (1 LITE) ^④	CENTER OF GLASS U-FACTOR	INWARD OPENING UNITS				OUTWARD OPENING UNITS			
		UNIT U-FACTOR	SHGC ^⑤	VT ^⑥	2015 ENERGY STAR	UNIT U-FACTOR	SHGC ^⑤	VT ^⑥	2015 ENERGY STAR
Double IG Clear (air filled)	.48	.50	.56	.59	-	.51	.56	.59	-
Double IG Standard Low E (argon filled)	.25	.34	.20	.45	-	.35	.20	.45	-
Double IG Standard Low E (air filled)	.30	.38	.20	.45	-	.39	.20	.45	-
Double IG Standard Low E #2 & #4 surfaces (argon filled)	.20	.31	.19	.43	-	.32	.19	.43	-
Double IG Standard Low E #2 & #4 surfaces (air filled)	.24	.33	.20	.43	-	.34	.20	.43	-
Triple IG Low E x 2 (argon filled)	.12	.24	.17	.32	*	.25	.17	.32	*
Triple IG Low E x 2 (air filled)	.15	.27	.17	.32	*	.27	.17	.32	*
Double IG Alternate Higher SHGC Low E (argon filled)	.25	.34	.30	.52	-	.35	.30	.52	-
Double IG Alternate Higher SHGC Low E (air filled)	.29	.38	.30	.52	-	.39	.30	.52	-
Double IG Alternate Higher SHGC Low #2 & #4 surfaces (argon filled)	.20	.31	.29	.50	-	.32	.29	.50	-
Double IG Alternate Higher SHGC Low #2 & #4 surfaces (air filled)	.24	.33	.29	.50	-	.34	.29	.50	-
Triple IG Alternate Higher SHGC Low E (argon filled)	.12	.24	.26	.42	**	.25	.26	.42	**
Triple IG Alternate Higher SHGC Low E (air filled)	.15	.27	.26	.42	**	.28	.26	.42	**

NOTES

③ U-Factor, SHGC, & VT for NW Reinforced 647 system unhung panels will be about the same except in some cases variations of +/- .01 from what is shown.

④ NFRC simulated U-factors of units with a horizontal mullion will have values of about .01 to .02 higher than units with no horizontal mullion. Please contact NanaWall for details.





⑤ SHGC = Solar Heat Gain Coefficient
⑥ VT = Visible Transmittance

* 2015 Energy Star Qualification Criteria: U-Factor for doors in all climate zones ≤.30, SHGC ≤.25 in South/South Central zones, and ≤.40 in North/North Central zones. (For guidance only. NanaWall is not a participant of the Energy Star program.)

** Meets SHGC Energy Star Qualification criteria for North/North Central zones only.

Shown above are thermal values for select glass options only. Thermal values for many other glass options are available. These may be able to meet specific requirements, such as Energy Star values for other zones, CA Title 24 prescriptive values, other state and local energy codes, etc. Thermal values for glass with other Low E coatings and Suntuitive dynamic glass are available. Please contact NanaWall for more information.

Low Profile Saddle Sill NW Reinforced 647

TYPE OF TEST	INWARD OPENING UNITS	OUTWARD OPENING UNITS	
 Air Infiltration ^① ASTM E-283, ft ³ /min./ft. and NFRC 400	@ 1.57 psf (75 Pa): 0.11 (0.12 exfiltration) A2 ^②	@ 1.57 psf (75 Pa): 0.12 (0.12 exfiltration) A2 ^②	
	@ 6.24 psf (300 Pa): 0.29	@ 6.24 psf (300 Pa): 0.29	
 Water Penetration ^{①*} ASTM E-547 and E-331	No uncontrolled water entry ^① @ 5.43 psf (260 Pa)		
	Subject to the following adaptations of the sill in the field by others; <ol style="list-style-type: none"> 1. Remove the gaskets covering the inner channel. 2. Drill weep holes through the bottom of the channel and drill weep holes from the middle channel to the exterior bottom hollow in sill (about one 5/16" weep hole per panel). 3. Drill weep holes through the lower front face of sill to the inner channel bottom (3/8" weep hole per panel). <p>Please note that due to the varying site requirements and conditions, these sills will not be prepared for drainage by NanaWall. If this drainage system is desired, we recommend that qualified professionals construct this system on the project site strictly in accordance with instructions provided by NanaWall and in accordance with good waterproofing techniques, if drain connections are not made or not possible, unit may leak with wind driven rain.</p>		
 Structural Load ^① ASTM E-330: pass See design windload charts for other sized panels <i>Note that the structural test pressures were 50% higher than the design pressures shown.</i>	DESIGN PRESSURE		
	Positive @ 70 psf (3330 Pa)	Negative @ 70 psf (3330 Pa)	DESIGN PRESSURE
	Positive @ 70 psf (3330 Pa)	Negative @ 70 psf (3330 Pa)	
	Uniform Load Deflection, L/175 @ 35 psf (1700 Pa)	Uniform Load Deflection, L/175 @ 35 psf (1700 Pa)	
	Class CW-PG35 - FLD 4000 x 2600	Class CW-PG35 - FLD 4000 x 2600	
 Forced Entry Resistance ^① AAMA-1304	In accordance with AAMA-1304 requirements		
 Operating Force ^① ASTM E-2068	The NW Reinforced 647 meets <ul style="list-style-type: none"> • Swing Panel: Open 1 lbf (2.8 N) & Close 1 lbf (3.9 N) • Folding Panels: Initiate Motion - Open 4 lbf (20 N) & Close 3 lbf (15 N) • Folding Panels: Maintain Motion - Open 1 lbf (3 N) & Close 1 lbf (4 N) 		
 Operation / Cycling Performance AAMA 920 & DIN EN 1191 Windows and Pedestrian Doors - Mechanical Durability	The NW Reinforced 647 meets: <ul style="list-style-type: none"> • "AAMA 920" requirement for swing panel attached to side jamb: 500,000 cycles - Pass • German "DIN EN 1191/12400 Classification," where a unit is tested after 20,000 opening and closing cycles and is still functional 		
<p>① Excerpts of results of 13' 1" W x 8' 6" H (4000 mm x 2600 mm) 4 panel unit (1L3R configuration) specific or equivalent to lab tested by Intertek Building & Construction, an independent testing laboratory in March 2020 per AAMA/WDMA/CSA 101/IS.2/A440-17, NAFS-17 - North American Fenestration Standard</p> <p>② For Canada, tested to NAFS-17 or equivalent and CSA A44051-09 (for drainage of standing water, weep hole in sill by others).</p> <p>* Water and structural ratings may not be applicable for configuration not tested, especially even panels plus even panels configurations.</p>			



Thermal Performance

NW Reinforced 647[®] - Rated, certified, and labeled in accordance with NFRC 100 + 200

TYPE OF GLASS (1 LITE) ^④	CENTER OF GLASS U-FACTOR	INWARD OPENING UNITS				OUTWARD OPENING UNITS			
		UNIT U-FACTOR	SHGC ^⑤	VT ^⑥	2015 ENERGY STAR	UNIT U-FACTOR	SHGC ^⑤	VT ^⑥	2015 ENERGY STAR
Double IG Clear (air filled)	.48	.50	.56	.59	-	.51	.56	.59	-
Double IG Standard Low E (argon filled)	.25	.35	.20	.45	-	.35	.20	.45	-
Double IG Standard Low E (air filled)	.30	.38	.20	.45	-	.39	.20	.45	-
Double IG Standard Low E #2 & #4 surfaces (argon filled)	.20	.32	.19	.43	-	.32	.19	.43	-
Double IG Standard Low E #2 & #4 surfaces (air filled)	.24	.34	.20	.43	-	.34	.20	.43	-
Triple IG Low E x 2 (argon filled)	.12	.25	.17	.32	*	.26	.17	.32	*
Triple IG Low E x 2 (air filled)	.15	.27	.17	.32	*	.28	.17	.32	*
Double IG Alternate Higher SHGC Low E (argon filled)	.25	.35	.30	.52	-	.36	.30	.52	-
Double IG Alternate Higher SHGC Low E (air filled)	.29	.38	.30	.52	-	.39	.30	.52	-
Double IG Alternate Higher SHGC Low E #2 & #4 surfaces (argon filled)	.20	.32	.29	.50	-	.32	.29	.50	-
Double IG Alternate Higher SHGC Low E #2 & #4 surfaces (air filled)	.24	.34	.29	.50	-	.34	.29	.50	-
Triple IG Alternate Higher SHGC Low E (argon filled)	.12	.25	.26	.42	**	.26	.26	.42	**
Triple IG Alternate Higher SHGC Low E (air filled)	.15	.28	.26	.42	**	.28	.26	.42	**

NOTES

③ U-Factor, SHGC, & VT for NW Reinforced 647 system unhunged panels will be about the same except in some cases variations of +/- .01 from what is shown.

④ NFRC simulated U-factors of units with a horizontal mullion will have values of about .01 to .02 higher than units with no horizontal mullion. Please contact NanaWall for details.

⑤ SHGC = Solar Heat Gain Coefficient
⑥ VT = Visible Transmittance

* 2015 Energy Star Qualification Criteria: U-Factor for doors in all climate zones ≤.30, SHGC ≤.25 in South/South Central zones, and ≤.40 in North/North Central zones. (For guidance only. NanaWall is not a participant of the Energy Star program.)

** Meets SHGC Energy Star Qualification criteria for North/North Central zones only.

Shown above are thermal values for select glass options only. Thermal values for many other glass options are available. These may be able to meet specific requirements, such as Energy Star values for other zones, CA Title 24 prescriptive values, other state and local energy codes, etc. Thermal values for glass with other Low E coatings and Suntuitive dynamic glass are available. Please contact NanaWall for more information.

Low Profile Saddle Sill with UniverSILL® NW Reinforced 647

TYPE OF TEST	OUTWARD OPENING UNITS		
 Air Infiltration ^① ASTM E-283, ft ³ /min./ft. and NFRC 400	@ 1.57 psf (75 Pa): 0.04 (0.02 exfiltration) A3 ^② <hr/> @ 6.24 psf (300 Pa): 0.07		
 Water Penetration ^{①*} ASTM E-547 and E-331	No uncontrolled water entry ^① @ 7.5 psf (360 Pa) UniverSILL transforms a Low Profile Saddle sill to obtain a better water rating when needed and to be easily removed when not required. To meet a water rating with the UniverSILL, the following needs to be done in the field by others: 1. Weepholes and drainage as described for the low profile saddle sill (minimum needed are weepholes from the middle channel). 2. Remove the gasket covering the inner channel and insert the UniverSILL. 3. Seals at ends at the side jambs.		
 Structural Load ^① ASTM E-330: pass See design windload charts for other sized panels <i>Note that the structural test pressures were 50% higher than the design pressures shown.</i>	DESIGN PRESSURE <table border="1" style="width: 100%; border-collapse: collapse;"> <tr> <td style="text-align: center;"> Positive @ 70 psf (3330 Pa) </td> <td style="text-align: center;"> Negative @ 70 psf (3330 Pa) </td> </tr> </table> <hr/> Uniform Load Deflection, L/175 @ 35 psf (1700 Pa) Class CW-PG35 - FLD 4000 x 2600 & Class LC-PG60 - FLD 4000 x 2600	Positive @ 70 psf (3330 Pa)	Negative @ 70 psf (3330 Pa)
Positive @ 70 psf (3330 Pa)	Negative @ 70 psf (3330 Pa)		
 Forced Entry Resistance ^① AAMA-1304	In accordance with AAMA-1304 requirements		
 Operating Force ^① ASTM E-2068	The NW Reinforced 647 meets <ul style="list-style-type: none"> Swing Panel: Open 1 lbf (2.8 N) & Close 1 lbf (3.9 N) Folding Panels: Initiate Motion - Open 4 lbf (20 N) & Close 3 lbf (15 N) Folding Panels: Maintain Motion - Open 1 lbf (3 N) & Close 1 lbf (4 N) 		
 Operation / Cycling Performance AAMA 920 & DIN EN 1191 Windows and Pedestrian Doors - Mechanical Durability	The NW Reinforced 647 meets: <ul style="list-style-type: none"> "AAMA 920" requirement for swing panel attached to side jamb: 500,000 cycles - Pass German "DIN EN 1191/12400 Classification," where a unit is tested after 20,000 opening and closing cycles and is still functional 		

① Excerpts of results of 13' 1" W x 8' 6" H (4000 mm x 2600 mm) 4 panel unit (1L3R configuration) specific or equivalent to lab tested by Intertek Building & Construction, an independent testing laboratory in March 2020 per AAMA/WDMA/CSA 101/I.S.2/A440-17, NAFS-17 - North American Fenestration Standard

② For Canada, tested to NAFS-17 or equivalent and CSA A44051-09 (for drainage of standing water, weep hole in sill by others).

* Water and structural ratings may not be applicable for configuration not tested, especially even panels plus even panels configurations.



Thermal Performance

NW Reinforced 647^③ - Rated, certified, and labeled in accordance with NFRC 100 + 200

		OUTWARD OPENING UNITS			
TYPE OF GLASS (1 LITE) ④	CENTER OF GLASS U-FACTOR	UNIT U-FACTOR	SHGC ⑤	VT ⑥	2015 ENERGY STAR
Double IG Clear (air filled)	.48	.51	.56	.59	-
Double IG Standard Low E (argon filled)	.25	.35	.20	.45	-
Double IG Standard Low E (air filled)	.30	.39	.20	.45	-
Double IG Standard Low E #2 & #4 surfaces (argon filled)	.20	.32	.19	.43	-
Double IG Standard Low E #2 & #4 surfaces (air filled)	.24	.34	.20	.43	-
Triple IG Low E x 2 (argon filled)	.12	.26	.17	.32	*
Triple IG Low E x 2 (air filled)	.15	.28	.17	.32	*
Double IG Alternate Higher SHGC Low E (argon filled)	.25	.36	.30	.52	-
Double IG Alternate Higher SHGC Low E (air filled)	.29	.39	.30	.52	-
Double IG Alternate Higher SHGC Low E #2 & #4 surfaces (argon filled)	.20	.32	.29	.50	-
Double IG Alternate Higher SHGC Low E #2 & #4 surfaces (air filled)	.24	.34	.29	.50	-
Triple IG Alternate Higher SHGC Low E (argon filled)	.12	.26	.26	.42	**
Triple IG Alternate Higher SHGC Low E (air filled)	.15	.28	.26	.42	**

NOTES

③ U-Factor, SHGC, & VT for NW Reinforced 647 system unHINGED panels will be about the same except in some cases variations of +/- .01 from what is shown.

④ NFRC simulated U-factors of units with a horizontal mullion will have values of about .01 to .02 higher than units with no horizontal mullion. Please contact NanaWall for details.

⑤ SHGC = Solar Heat Gain Coefficient
⑥ VT = Visible Transmittance

* 2015 Energy Star Qualification Criteria: U-Factor for doors in all climate zones ≤.30, SHGC ≤.25 in South/South Central zones, and ≤.40 in North/North Central zones. (For guidance only. NanaWall is not a participant of the Energy Star program.)

** Meets SHGC Energy Star Qualification criteria for North/North Central zones only.

Shown above are thermal values for select glass options only. Thermal values for many other glass options are available. These may be able to meet specific requirements, such as Energy Star values for other zones, CA Title 24 prescriptive values, other state and local energy codes, etc. Thermal values for glass with other Low E coatings and Suntuitive dynamic glass are available. Please contact NanaWall for more information.

Design Windload Chart | NW Reinforced 647

Applies to Positive and Negative Design Pressure for both Inswing and Outswing Units with the Performance Sill and Low Profile Saddle Sill, and Inswing Units with Performance Sill

(In Accordance with Allowable Stress Design (ASD) Design Pressures*)

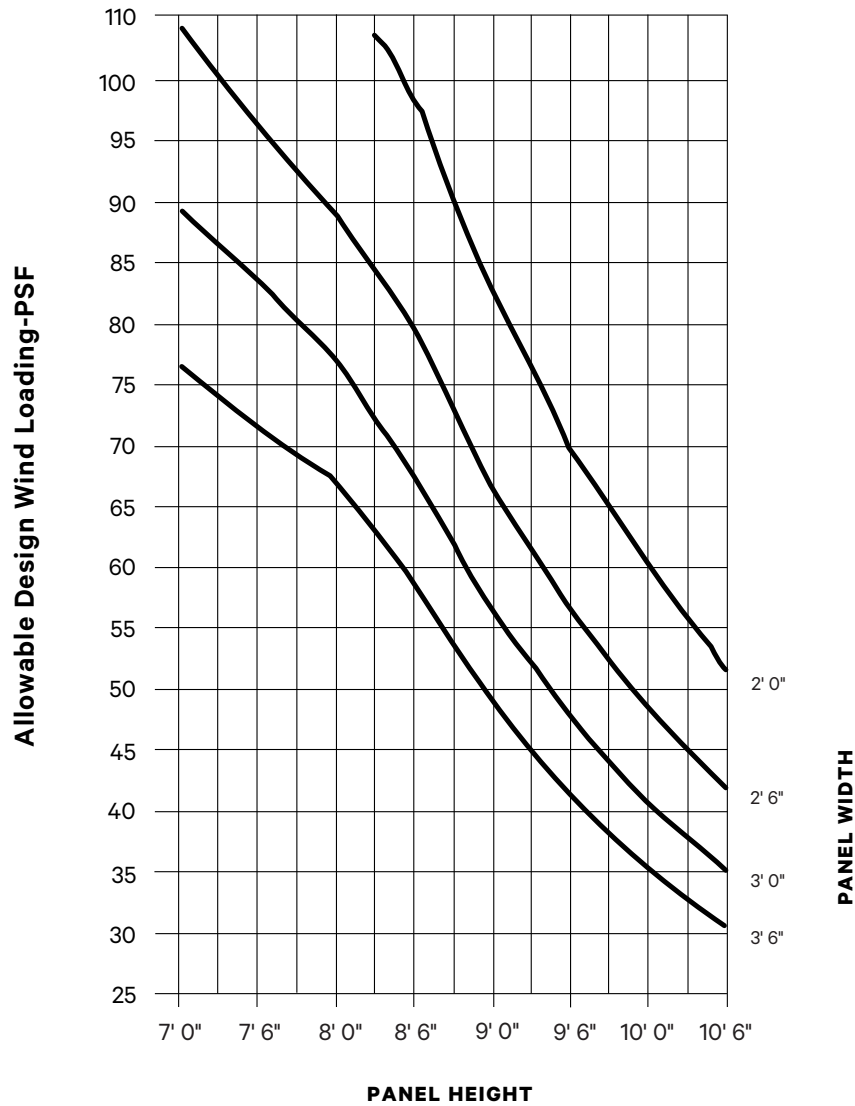

Any Custom Size is Possible. See Maximum Frame Size Chart for Possible Sizes.

(Derived from Comparative Analysis) Test Panel Size: 3' 3" W x 8' 2" H.

Please note that some jurisdictions may limit the use of these charts or may not accept them at all. Design pressures and/or sizes may be restricted to what was tested. These charts are also not restricted by any water ratings or deflection limitations. For Florida approval products, please see the FL Evaluation Report and Installation Instructions for restrictions. This chart is only applicable for units with standard NanaWall supplied locking.

* If the project design pressures have been calculated in accordance with Ultimate Design Wind Speed (ULT), then these design pressures have to be multiplied by a factor of 0.6 to obtain the equivalent ASD design pressures shown in this chart.

Maximum Size Chart NW Reinforced 647 (Double Glazed)

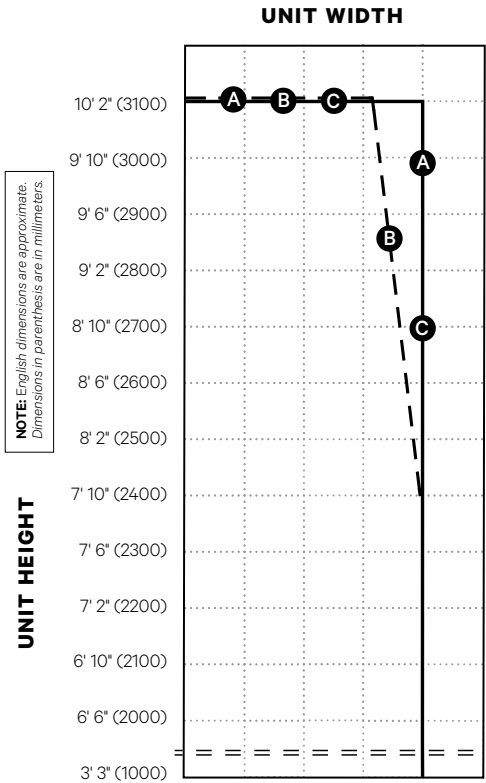

NOTE: English dimensions are approximate. Dimensions in parenthesis are in millimeters.

UNIT HEIGHT

Number of Panels in Unit	1	1' 11" (600)	2' 3" (700)	2' 7" (800)	2' 11" (900)	3' 3" (1000)
	2	3' 11" (1200)	4' 7" (1400)	5' 3" (1600)	5' 10" (1800)	6' 6" (2000)
	3	5' 10" (1800)	6' 10" (2100)	7' 10" (2400)	8' 10" (2700)	9' 10" (3000)
	4	7' 10" (2400)	9' 2" (2800)	10' 6" (3200)	11' 9" (3600)	13' 1" (4000)
	5	9' 10" (3000)	11' 5" (3500)	13' 1" (4000)	14' 9" (4500)	16' 4" (5000)
	6	11' 9" (3600)	13' 10" (4200)	15' 8" (4800)	17' 8" (5400)	19' 8" (6000)
	7	13' 10" (4200)	16' 0" (4900)	18' 4" (5600)	20' 8" (6300)	22' 10" (7000)
	8	15' 8" (4800)	18' 4" (5600)	20' 11" (6400)	23' 7" (7200)	26' 1" (8000)
	9	17' 9" (5400)	20' 7" (6300)	23' 6" (7200)	26' 6" (8100)	29' 4" (9000)
	10	19' 8" (6000)	22' 10" (7000)	26' 1" (8000)	29' 6" (9000)	32' 9" (10000)
	11	21' 7" (6600)	25' 1" (7700)	28' 8" (8800)	32' 5" (9900)	36' 1" (11000)
	12	23' 6" (7200)	27' 4" (8400)	31' 5" (9600)	35' 5" (10800)	39' 4" (12000)

Frame Width of Unit

(Wider widths possible with addition of Panel Sets.)

Any Custom Size is Possible Up to the Maximum Size Limit Lines Shown

MAXIMUM SIZE LIMIT LINE OF:

A CONFIGURATIONS ———
(Swing panel hinged at jamb only.)

Standard Configurations:
 1L 1R | 1L 4R | 2L 1R | 4L 1R | 6L 1R
 1L 2R | 1L 6R

Sample Configurations with Unhinged FourFold or SixFold Panel Sets:
 1L 4L/R | 1L 6L/R 1R | 4L/R 1R

Addition of Panel Sets to all A Configurations possible.

C CONFIGURATIONS ———
(No swing panels.)

Standard Configurations:
 2L | 4L | 6L | 2L 2R | 4L 2R | 6L 2R
 2R | 4R | 6R | 2L 4R | 4L 4R | 6L 4R
 2L 6R | 4L 6R | 6L 6R

Sample Configurations with Unhinged FourFold or SixFold Panel Sets:
 2L 4L/R | 4L/R 4R | 6L 6L/R | 4L/R 4L/R | 6L/R 4L/R

Addition of Panel Sets to all C Configurations possible.

B CONFIGURATIONS - - -
(Swing panel as part of odd number of panels to one side.)

Standard Configurations:
 3L | 5L | 1L 3R | 3L 2R | 5L 1R | 4L 3R | 5L 3R | 5L 4R | 5L 6R
 3R | 5R | 3L 1R | 3L 3R | 2L 5R | 5L 2R | 3L 6R | 6L 3R | 6L 5R
 2L 3R | 1L 5R | 3L 4R | 3L 5R | 4L 5R | 5L 5R

Sample Configurations with Unhinged FourFold or SixFold Panel Sets:
 3L 4L/R | 3L 6L/R | 3L 4L/R 3R

Addition of Panel Sets to all B Configurations possible.

GLAZING

- Glass thicknesses from 7/8" (22 mm) to 1 7/16" (36 mm) can be accommodated.
- Maximum size chart is based on maximum glass weight of 30 kg/m² (6 lbs/ft²).
- Dry glazing system.

NOTES

- Max. panel width swing panel attached to side jamb 3' 3" (1000 mm).
- Min. panel width 23 5/8" (600 mm) for paired panels hinged to side jamb.
- Min. panel width 21 5/8" (550 mm) for Panel Sets 4L/R, 6L/R.
- Max. number of hinged panels to one side is 6.
- Up to one unhinged FourFold or SixFold panel set possible in a unit. Additional adequate structural lateral support by others where panel stack.
- Configurations with even panels meeting even panels, including panel sets, provide lower weather resistant results from tested units.
- For other configurations, contact NanaWall.

Maximum Size Chart NW Reinforced 647 (Triple Glazed)

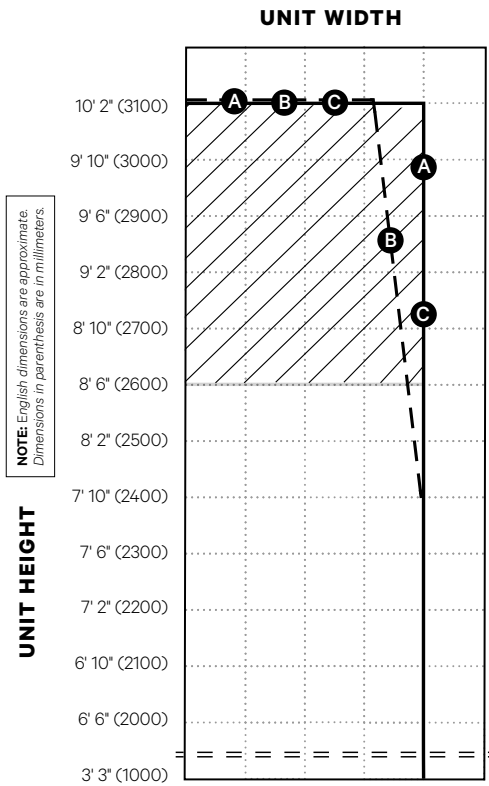

NOTE: English dimensions are approximate. Dimensions in parenthesis are in millimeters.

UNIT HEIGHT

UNIT WIDTH

Number of Panels in Unit

1	1' 11" (600)	2' 3" (700)	2' 7" (800)	2' 11" (900)	3' 3" (1000)
2	3' 11" (1200)	4' 7" (1400)	5' 3" (1600)	5' 10" (1800)	6' 6" (2000)
3	5' 10" (1800)	6' 10" (2100)	7' 10" (2400)	8' 10" (2700)	9' 10" (3000)
4	7' 10" (2400)	9' 2" (2800)	10' 6" (3200)	11' 9" (3600)	13' 1" (4000)
5	9' 10" (3000)	11' 5" (3500)	13' 1" (4000)	14' 9" (4500)	16' 4" (5000)
6	11' 9" (3600)	13' 10" (4200)	15' 8" (4800)	17' 8" (5400)	19' 8" (6000)
7	13' 10" (4200)	16' 0" (4900)	18' 4" (5600)	20' 8" (6300)	22' 10" (7000)
8	15' 8" (4800)	18' 4" (5600)	20' 11" (6400)	23' 7" (7200)	26' 1" (8000)
9	17' 9" (5400)	20' 7" (6300)	23' 6" (7200)	26' 6" (8100)	29' 4" (9000)
10	19' 8" (6000)	22' 10" (7000)	26' 1" (8000)	29' 6" (9000)	32' 9" (10000)
11	21' 7" (6600)	25' 1" (7700)	28' 8" (8800)	32' 5" (9900)	36' 1" (11000)
12	23' 6" (7200)	27' 4" (8400)	31' 5" (9600)	35' 5" (10800)	39' 4" (12000)

Frame Width of Unit

(Wider widths possible with addition of Panel Sets.)

Any Custom Size is Possible Up to the Maximum Size Limit Lines Shown

MAXIMUM SIZE LIMIT LINE OF:

A CONFIGURATIONS ———

(Swing panel hinged at jamb only.)

Standard Configurations:

1L 1R	2L 1R	4L 1R	6L 1R
1L 2R	1L 4R	1L 6R	

Sample Configurations with Unhinged FourFold or SixFold Panel Sets:

1L 4L/R	4L/R 1R	1L 6L/R 1R
---------	---------	------------

Addition of Panel Sets to all A Configurations possible.

C CONFIGURATIONS ———

(No swing panels.)

Standard Configurations:

2L	4L	6L	2L 2R	4L 2R	6L 2R
2R	4R	6R	2L 4R	4L 4R	6L 4R
			2L 6R	4L 6R	6L 6R

Sample Configurations with Unhinged FourFold or SixFold Panel Sets:

2L 4L/R	4L/R 4R	6L 6L/R	4L/R 4L/R	6L/R 4L/R
---------	---------	---------	-----------	-----------

Addition of Panel Sets to all C Configurations possible.

B CONFIGURATIONS - - -

(Swing panel as part of odd number of panels to one side.)

Standard Configurations:

3L	5L	1L 3R	3L 2R	5L 1R	4L 3R	5L 3R	5L 4R	5L 6R
3R	5R	3L 1R	3L 3R	2L 5R	5L 2R	3L 6R	6L 3R	6L 5R
		2L 3R	1L 5R	3L 4R	3L 5R	4L 5R	5L 5R	

Sample Configurations with Unhinged FourFold or SixFold Panel Sets:

3L 4L/R	3L 6L/R	3L 4L/R 3R
---------	---------	------------

Addition of Panel Sets to all B Configurations possible.

Horizontal mullion required for unit height taller than 8' 6" (2600 mm) such that no glass pane is more than 7' 10" (2400 mm) tall.

GLAZING

- Glass thicknesses from 1 7/16" (36 mm) to 1 3/4" (45 mm) can be accommodated.
- Maximum size chart is based on maximum glass weight of 30 kg/m² (6 lbs/ft²).
- Dry glazing system.

NOTES

- Max. panel width swing panel attached to side jamb 3' 3" (1000 mm).
- Min. panel width 23 5/8" (600 mm) for paired panels hinged to side jamb.
- Min. panel width 21 5/8" (550 mm) for Panel Sets 4L/R, 6L/R.
- Max. number of hinged panels to one side is 6.
- Up to one unhinged FourFold or SixFold panel set possible in a unit. Additional adequate structural lateral support by others where panels stack.
- Configurations with even panels meeting even panels, including panel sets, provide lower weather resistant results from tested units.
- For other configurations, contact NanaWall.

Maximum Size Chart NW Reinforced 647 - Single Swing Door (Double and Triple Glazed)

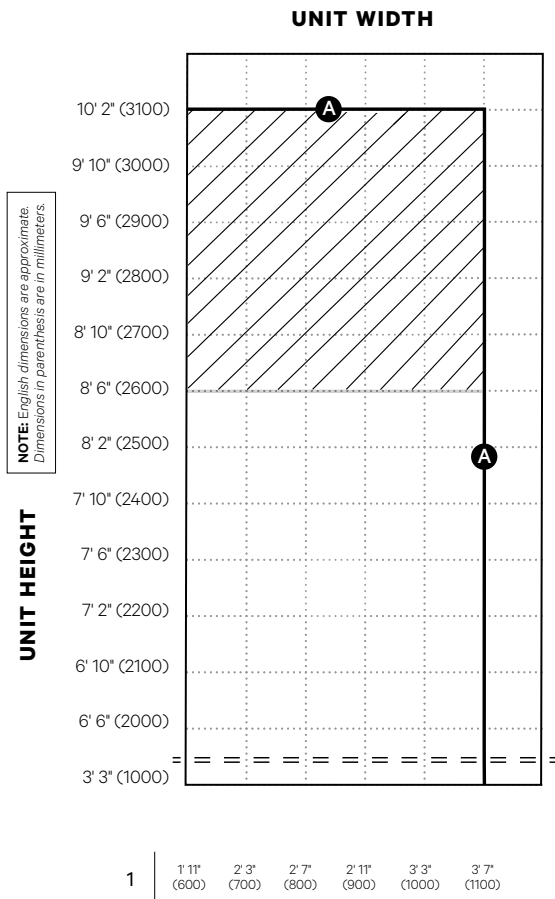

Frame Width of Unit

Single Swing Door Possible Up to the Maximum Size Limit Lines Shown

MAXIMUM SIZE LIMIT LINE OF:

A CONFIGURATIONS ———
(Swing door hinged at jamb only.)

Standard Configurations:

1L | 1R

Horizontal mullion required for triple glazing with unit height taller than 8' 6" (2600 mm) such that no glass pane is more than 7' 10" (2400 mm) tall.

GLAZING

- Glass thicknesses from 1/4" (6 mm) to 1 3/4" (45 mm) can be accommodated.
- Maximum size chart is based on maximum glass weight of 30 kg/m² (6 lbs/ft²).
- Dry glazing system.

NOTES

- Max. panel width swing panel attached to the side jamb 3' 7" (1100 mm).
- Min. panel width swing panel attached to the side jamb 21 5/8" (550 mm).
- For other options, contact NanaWall.

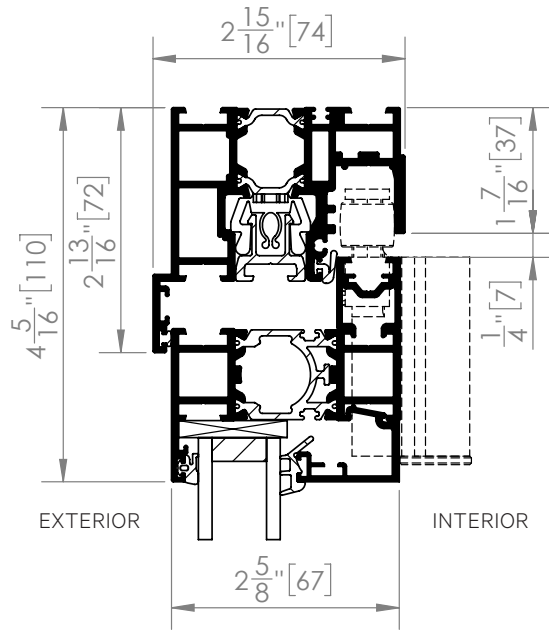

Detail 1.0
Head Jamb

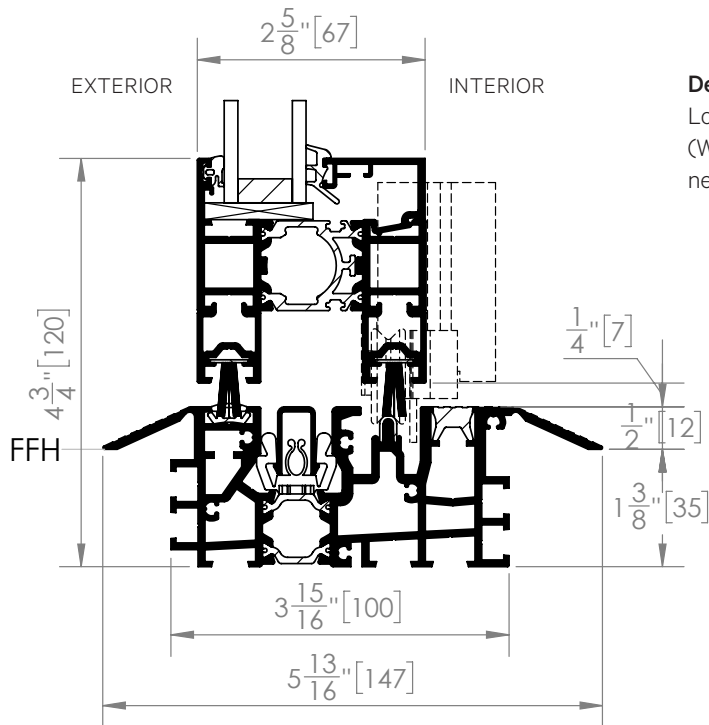

Detail 22.0
Low Profile Saddle Sill
(Weep holes and drainage by others necessary for water rating.)

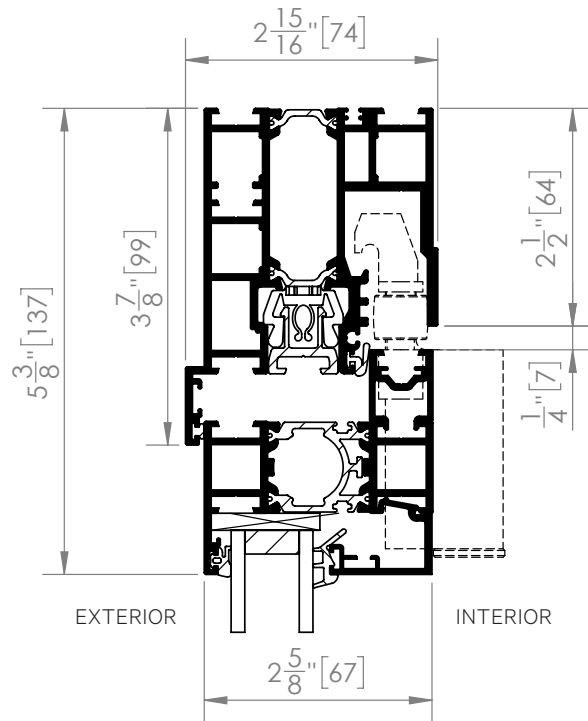

Detail 12.0
Head Jamb for
Unhinged Panel Sets

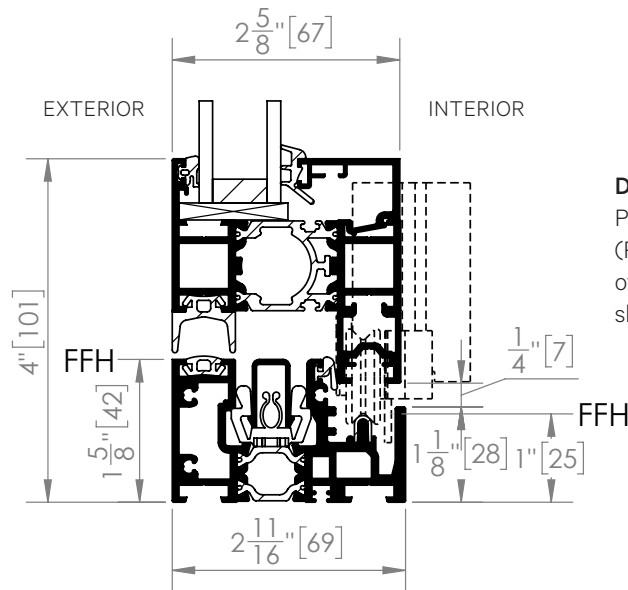

Detail 2.0
Performance Sill
(Proper drainage by others
of water exiting sill weep
slots necessary.)

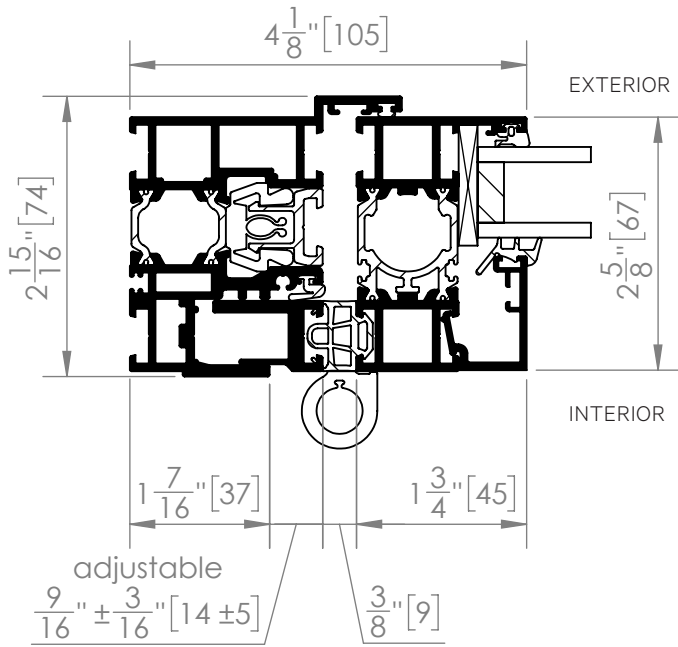

Detail 3.0
 Panel Hinged to Side Jamb

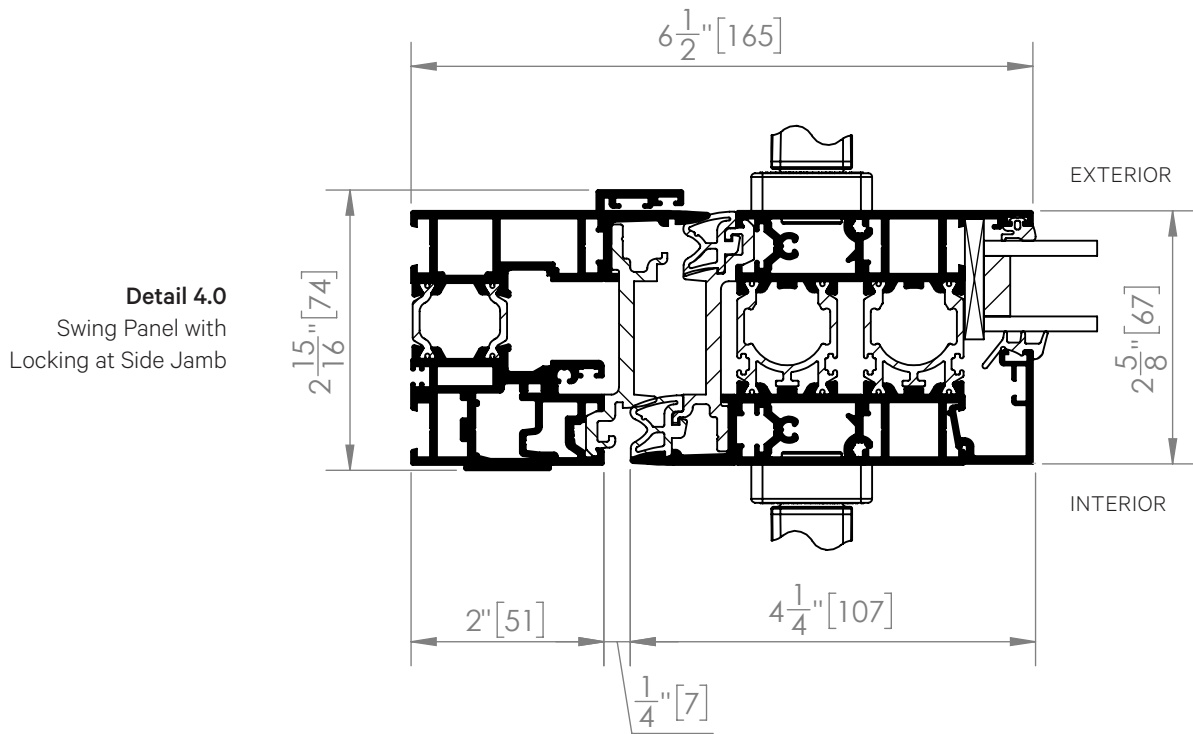

Detail 4.0
 Swing Panel with
 Locking at Side Jamb

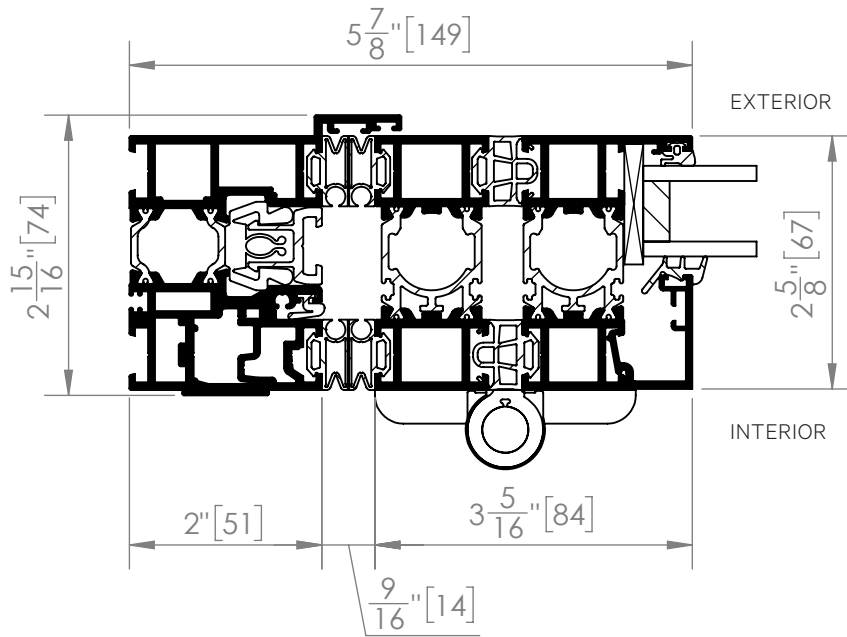

Detail 5.0

Panel with Running Post and Top and Bottom Rollers Attached Meeting at Side Jamb

(Note: Daylight opening "DLO" of the panel will be $1 \frac{5}{16}$ " [33.5 mm] wider than the adjacent attached panel.)

Detail 7C.0
Hinged Folding Panels

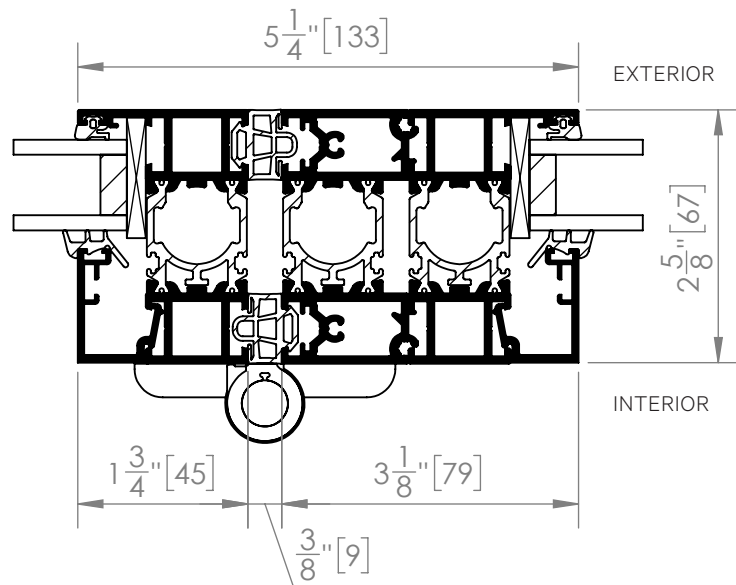

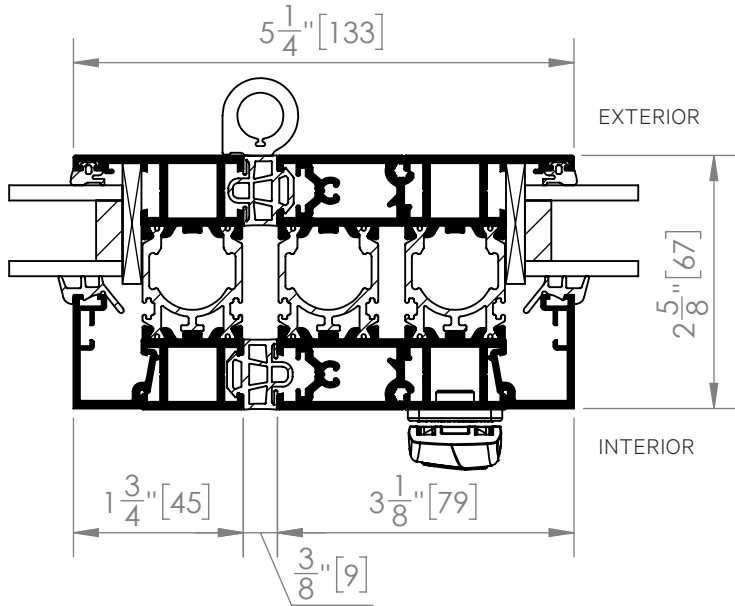

Detail 7.0
Hinged Folding Panels
with Locking

Detail 8.0
Pair of Swing Panels with
Primary Swing Panel with Lever
Handle Locking on Right and
Secondary Swing Panel with
Concealed Edge Lock on Left

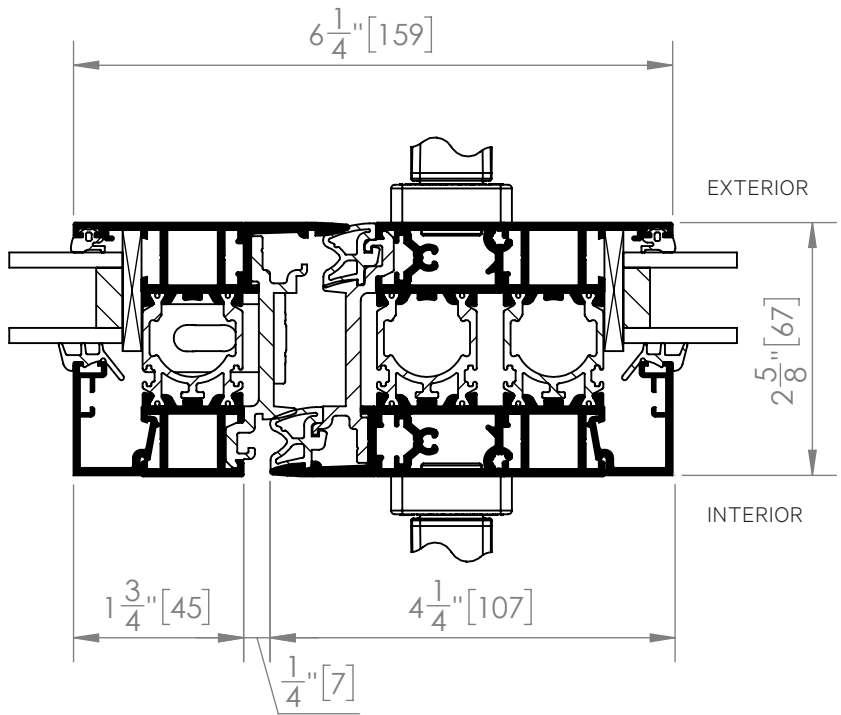

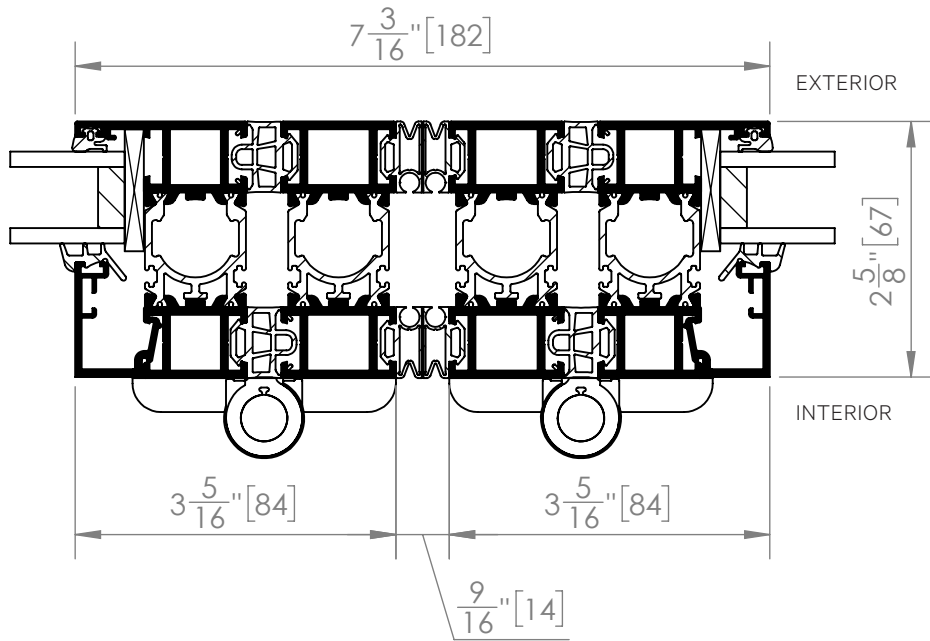

Detail 9.0
 Meeting of Folding Panels
 with Running Post and Top and
 Bottom Rollers Attached
 (Note: Daylight opening "DLO"
 of the panels will be 15/16"
 [33.5 mm] wider than the
 adjacent attached panels.)

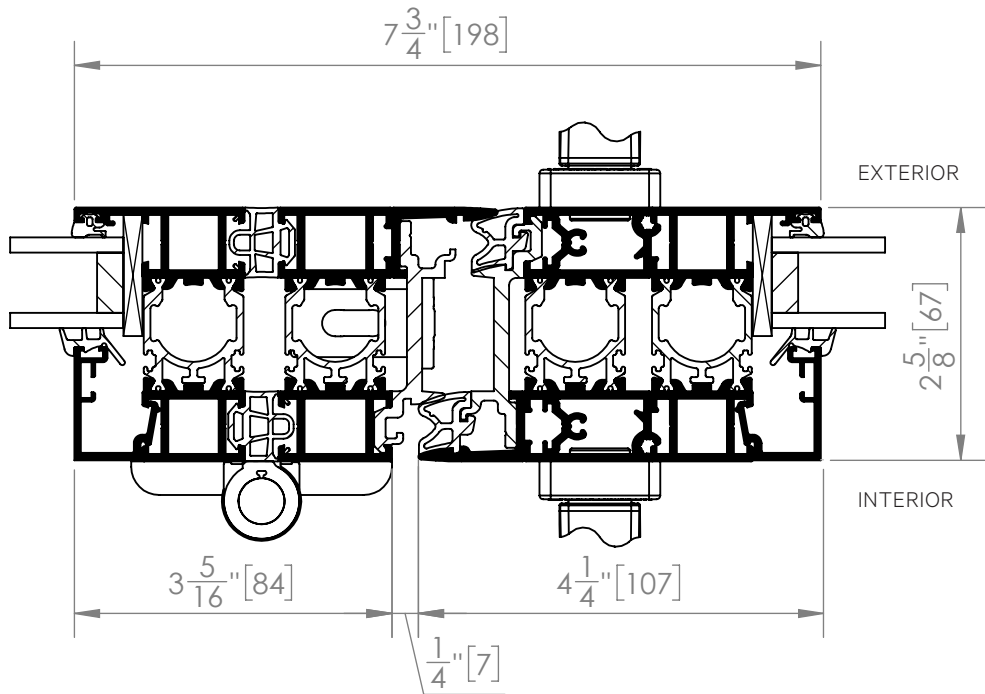

Detail 10.0
 Meeting of Swing Panel with
 Locking and Folding Panel
 with Running Post and Top
 and Bottom Rollers Attached
 (Note: Daylight opening "DLO"
 of the panel with the running
 post will be 15/16"
 [33.5 mm] wider than the
 adjacent attached panel.)

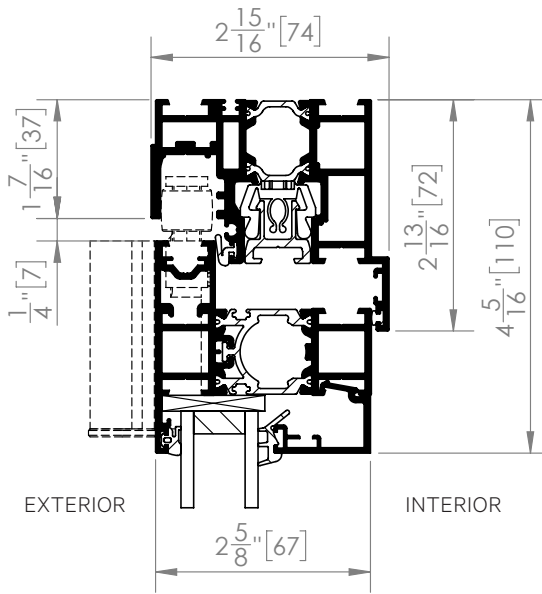

Detail 1.1
Head Jamb

Detail 22.1
Low Profile Saddle Sill
(Weep holes and drainage by others necessary for water rating.)

Detail 22.1 UniverSILL®
Low Profile Saddle Sill with UniverSILL®
(Weep holes and drainage by others necessary for water rating.)

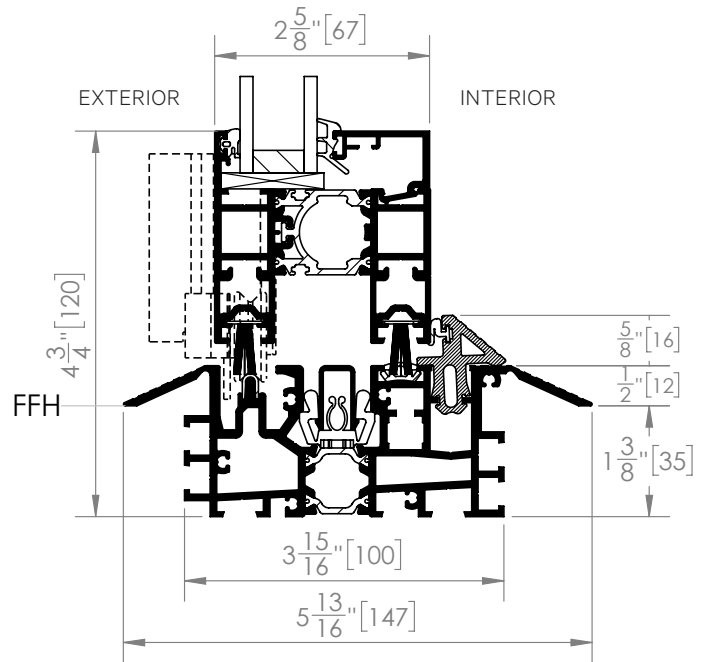
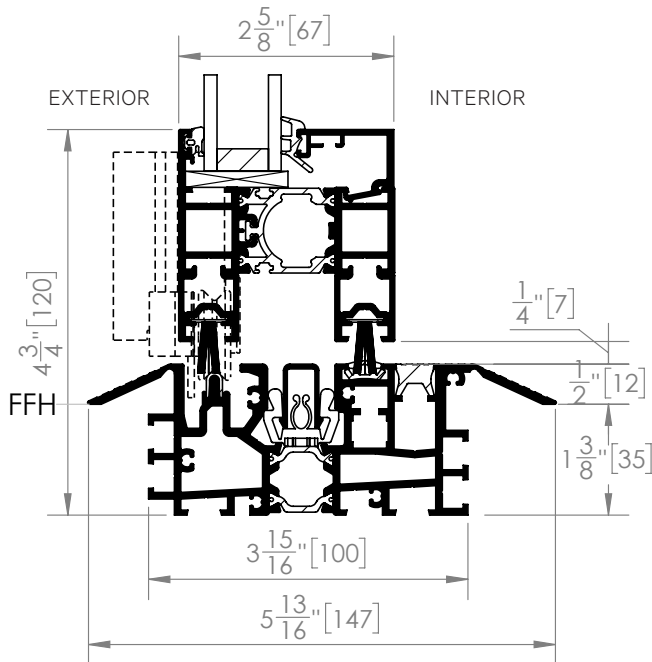

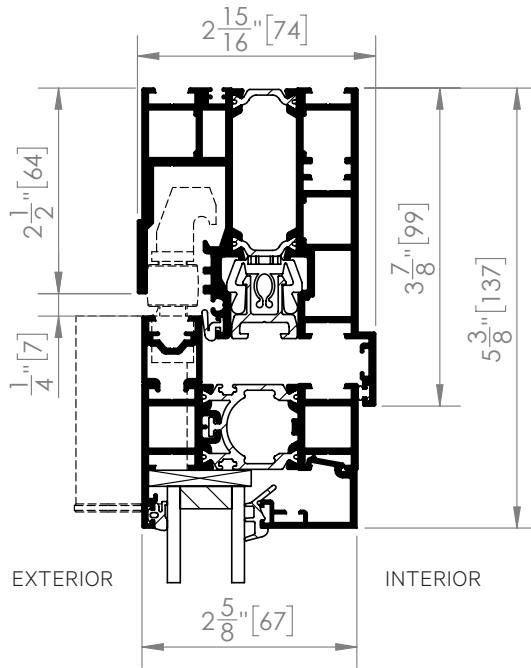

Detail 12.1
Head Jamb for UnHINGED Panel Sets

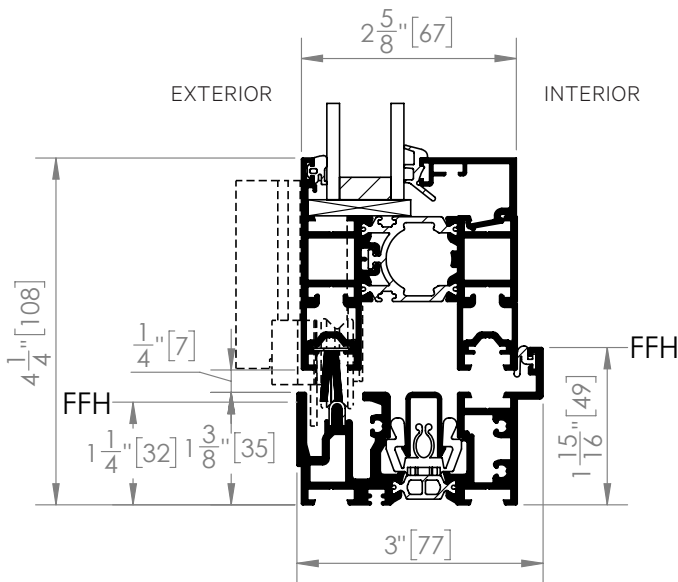

Detail 2.1
Performance Sill
(Proper drainage by others of water exiting weep slots necessary.)

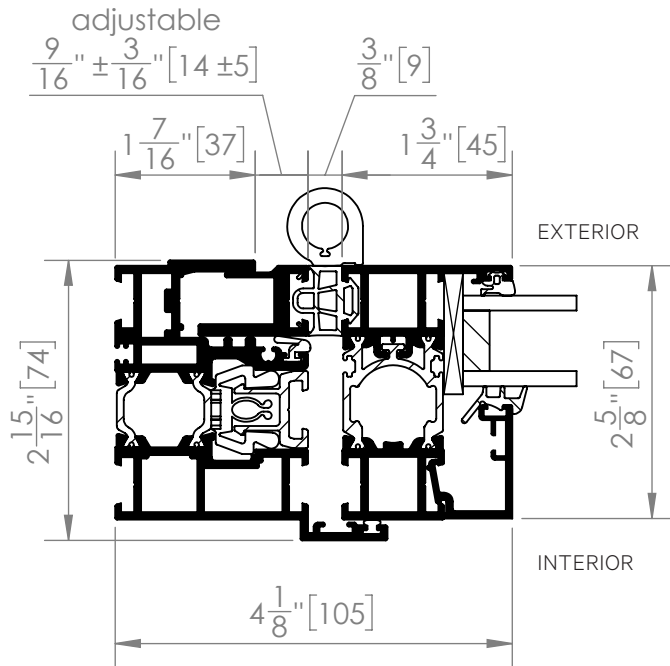

Detail 3.1
Panel Hinged to Side Jamb

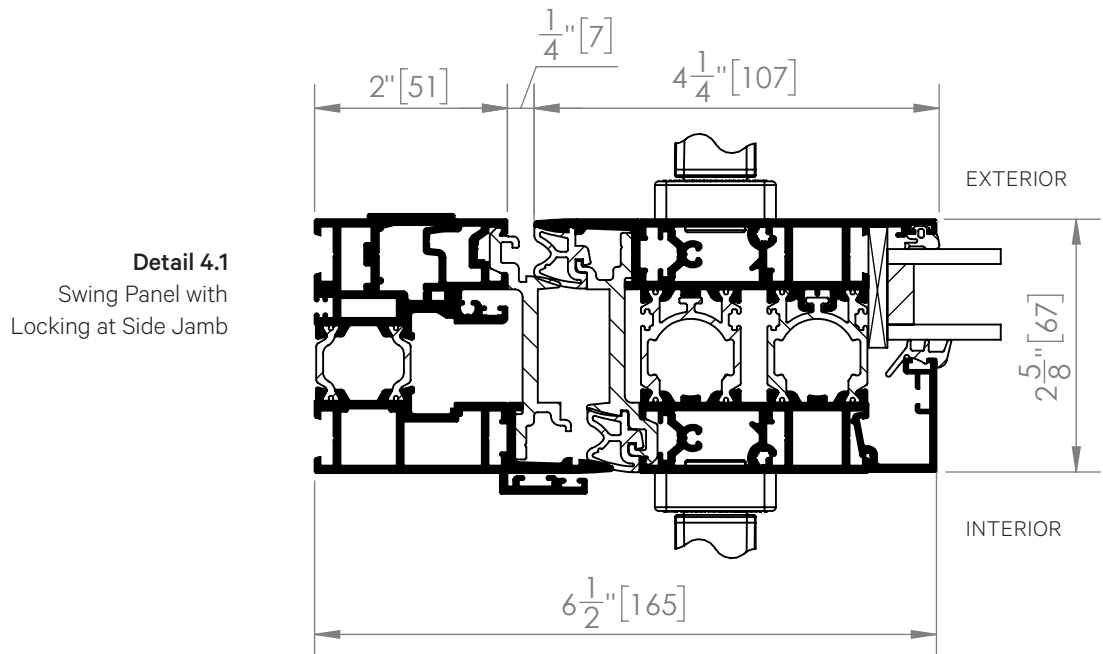

Detail 4.1
Swing Panel with
Locking at Side Jamb

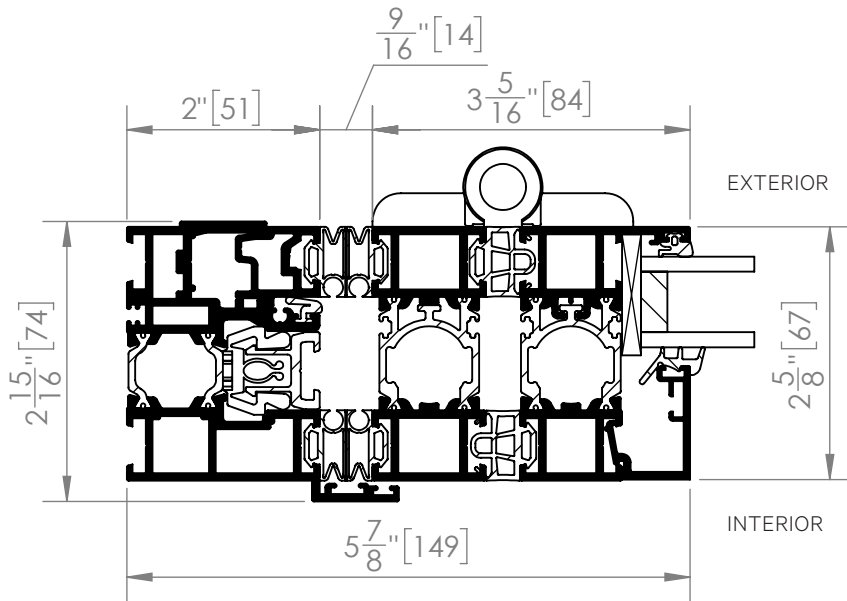

Detail 5.1
 Panel with Running Post and Top and Bottom Rollers Attached Meeting at Side Jamb
 (Note: Daylight opening "DLO" of the panel will be 1 5/16" [33.5 mm] wider than the adjacent attached panel.)

Detail 7C.1
 Hinged Folding Panels

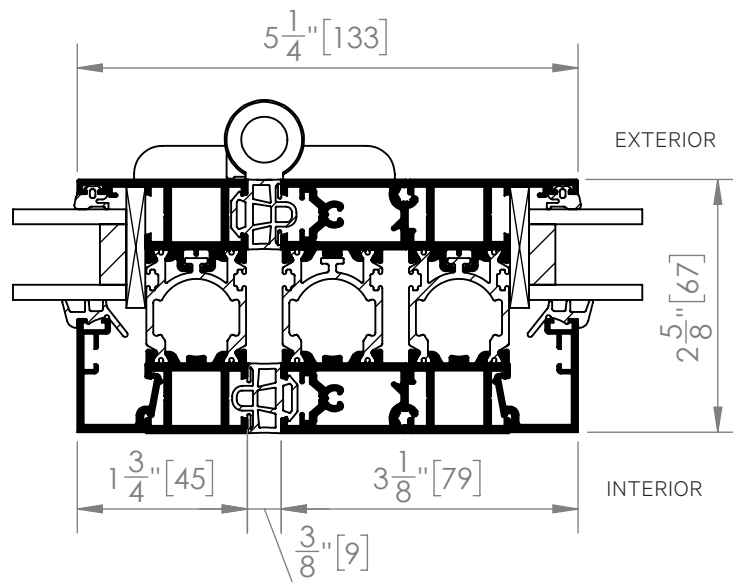

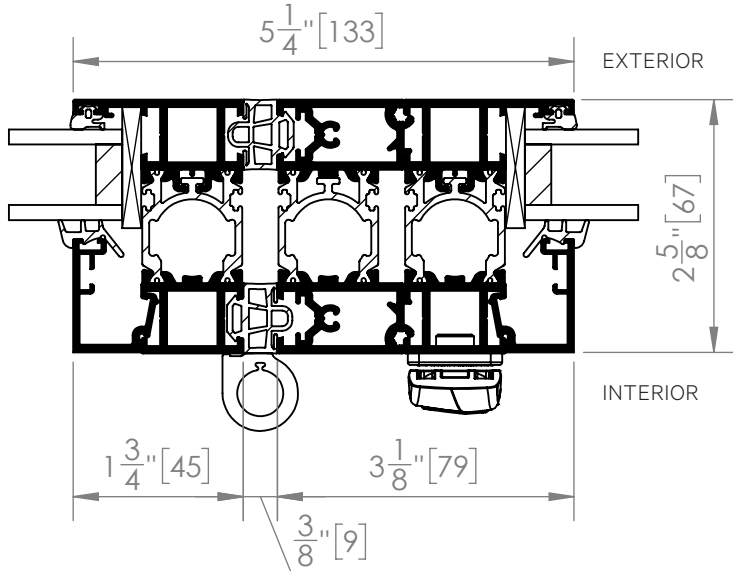

Detail 7.1
Hinged Folding Panels
with Locking

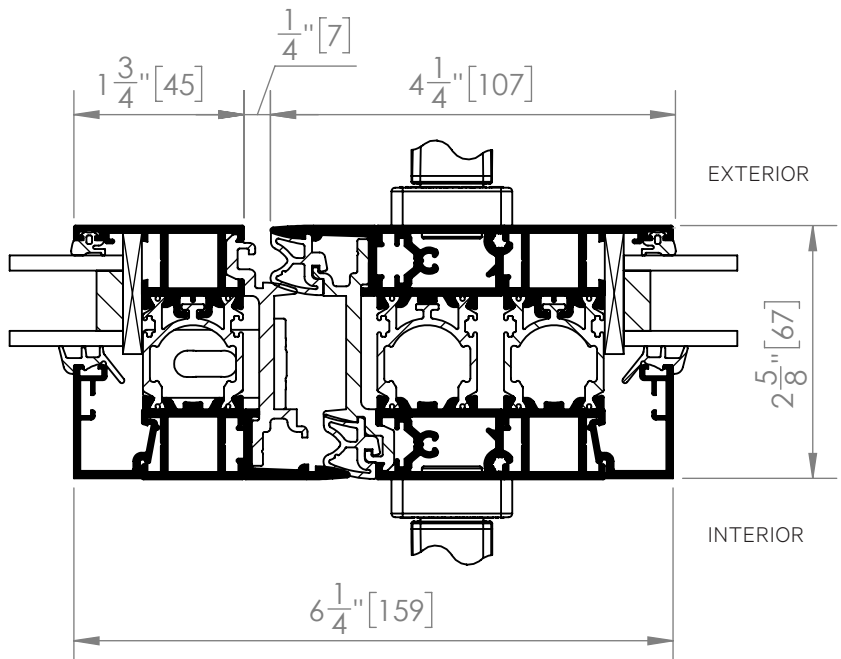

Detail 8.1
Pair of Swing Panels with
Primary Swing Panel with
Lever Handle Locking on
Right and Secondary Swing
Panel with Concealed Edge
Lock on Left

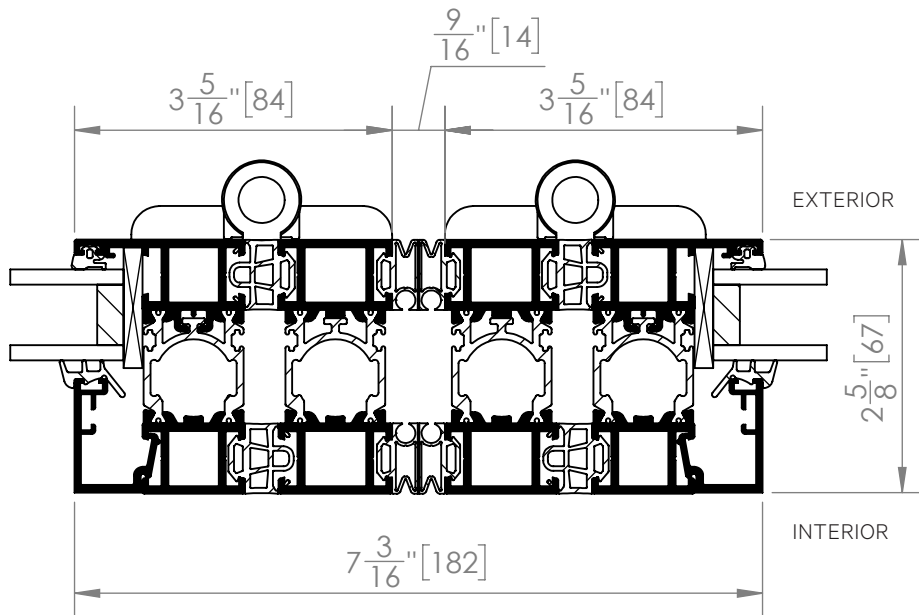

Detail 9.1

Meeting of Folding Panels with Running Post and Top and Bottom Rollers Attached
 (Note: Daylight opening "DLO" of the panels will be 1 5/16" [33.5 mm] wider than the adjacent attached panels.)

Detail 10.1
 Meeting of Swing Panel with Locking and Folding Panel with Running Post and Top and Bottom Rollers Attached
 (Note: Daylight opening "DLO" of the panel with the running post will be 1 5/16" [33.5 mm] wider than the adjacent attached panel.)

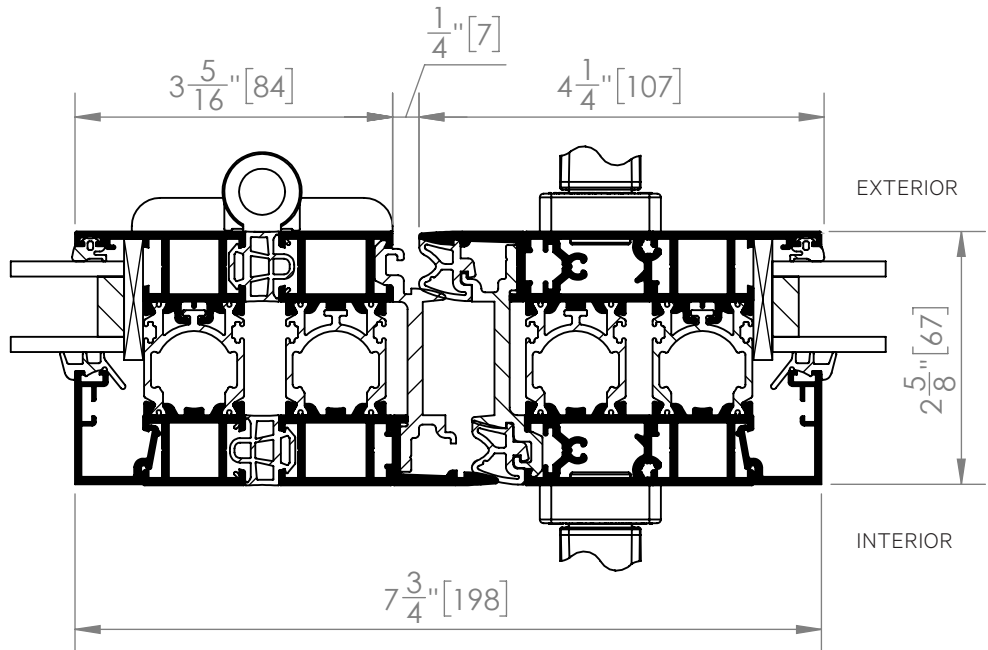

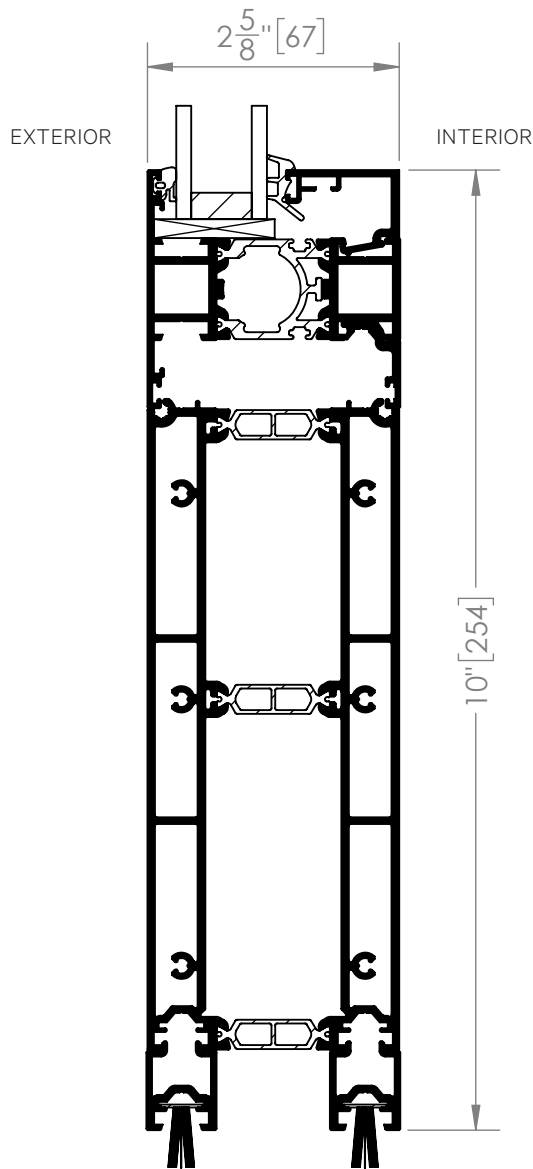

Typical Higher Bottom Rail

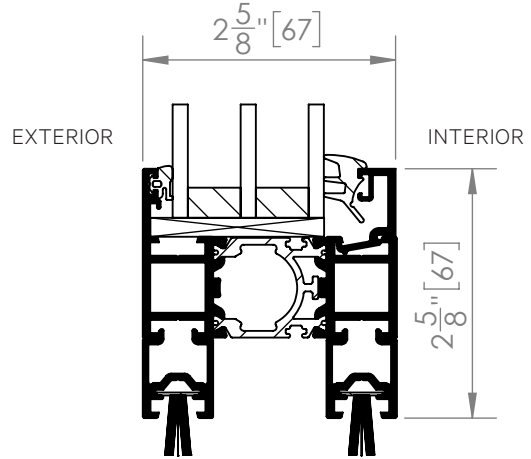

Typical Glass Stop Profile with Triple Glazing

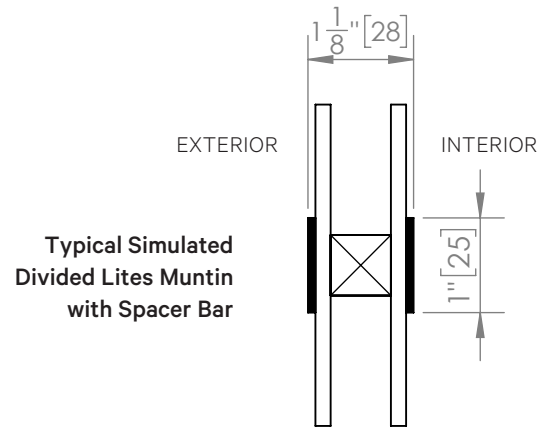

Typical Simulated Divided Lites Muntin with Spacer Bar

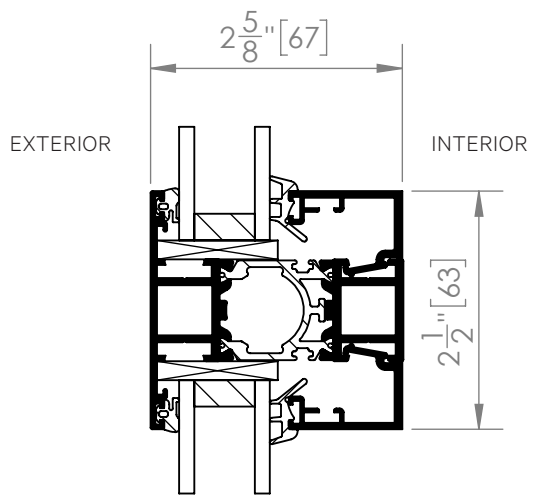

Typical Mullion Profile

Suggested Typical Installation

INSTALLATION NOTES

Suggested Typical Installation drawings shown are very general and may not be suitable for any particular installation. Product placement, fasteners, flashing, waterproofing, sealant, trim, and other details for specific surrounding conditions must be properly designed and provided by others.

INSTALLATION CONSIDERATIONS

The approximate weight of a panel with double glazing is 5.5-7.5 lbs/ft² (27-37 kg/m²), and with triple glazing is 7-8 lbs/ft² (34-39 kg/m²). The maximum vertical structural deflection of the header should be ¼" (6 mm) under full live and dead loads. Although for Floor Supported systems, there is no vertical live load deflection of the header from the weight of the panels, structural support for lateral loads (both windload and when the panels are stacked open) must be provided for the header, surrounding walls, and floor. For further information, see "Preparation of the Rough Opening" section in the Installation Instructions for the applicable system. An owner's manual with these Installation Instructions is available from NanaWall or from NanaWall's website.

It is recommended that all building dead loads be applied to the header prior to installing the NanaWall. If so and if a reasonable amount of time has been allowed for the effect of this dead load to be imposed on the header, then only the building's live load can be used to account for the above maximum header deflection of ¼" (6 mm). There may be additional structural requirements not mentioned here.

Note: For some jurisdictions, any standing water in sill channels must be drained. Weep holes for this purpose are to be done by others in the field, including drain connections if sill is recessed.

Inward Opening Details

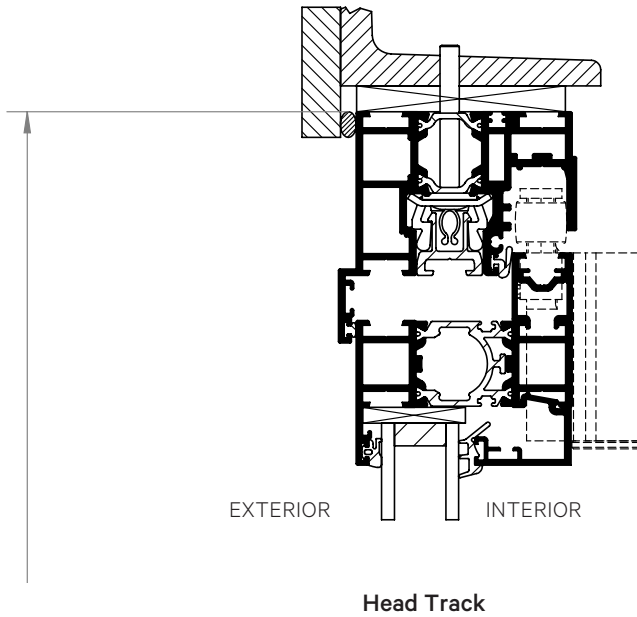

Head Track

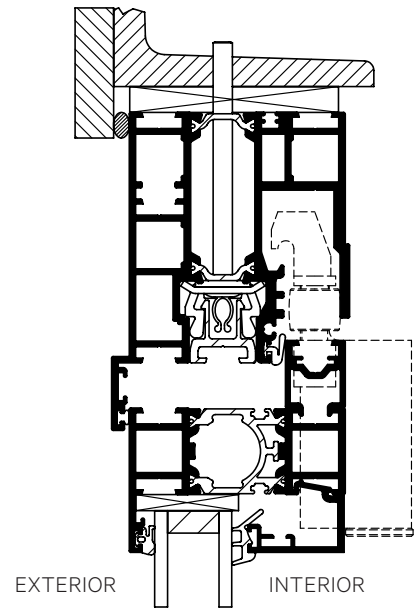

Head Track for Left/Right FourFold and SixFold Panel Sets

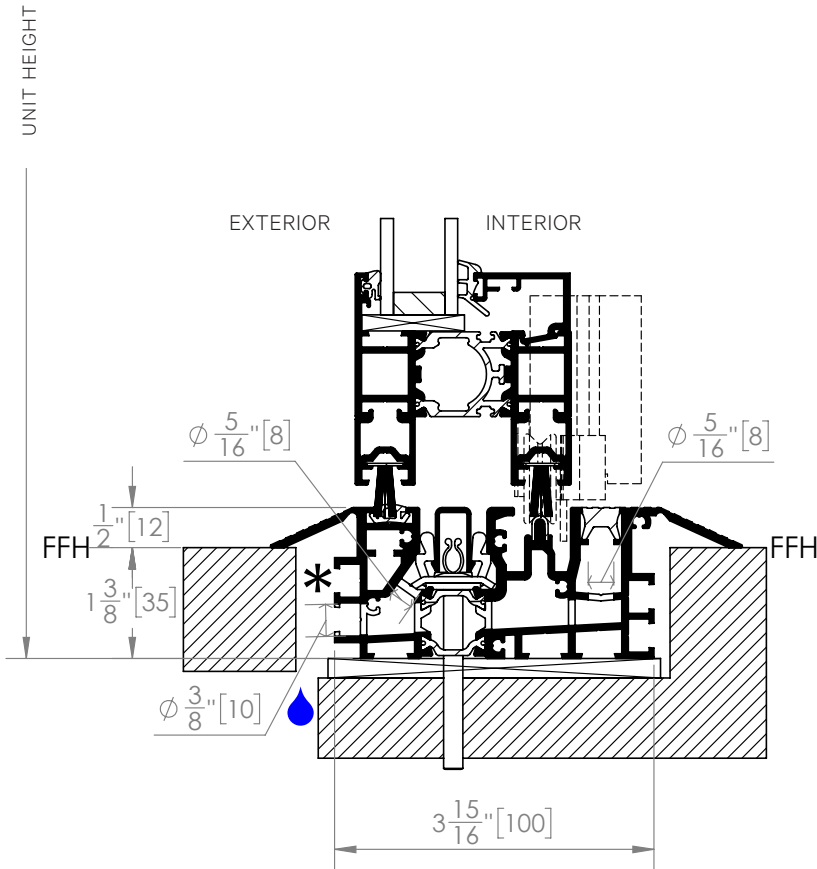

Low Profile Saddle Sill - Option 1
 (*Weep holes have to be unobstructed. Drainage by others is necessary for water rating. Please see detail drawing available from NanaWall for weep hole sizes, pattern, and spacing.)

Inward Opening Details

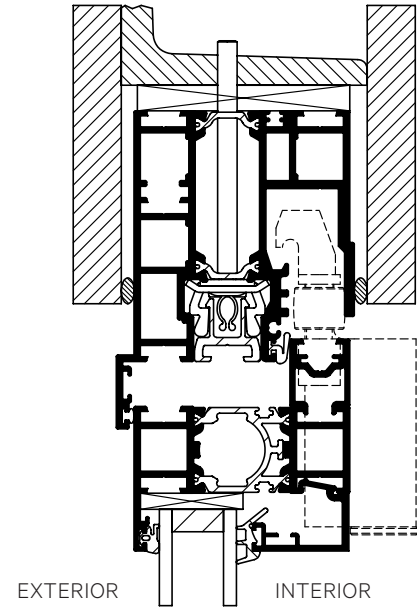
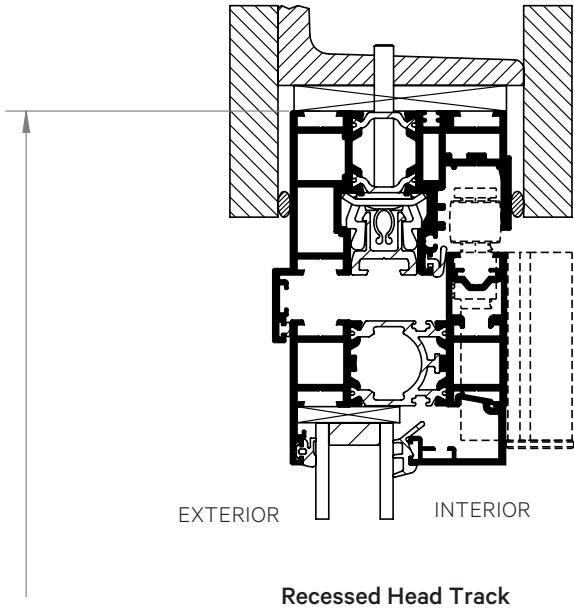

UNIT HEIGHT

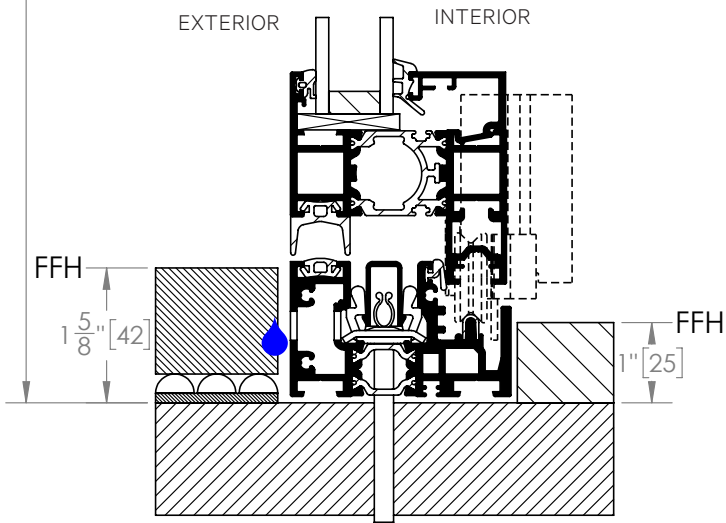

Performance Sill

(Weep slots have to be unobstructed. Details of the management of water exiting the weep slots must be designed and installed by others.)

Inward Opening Details

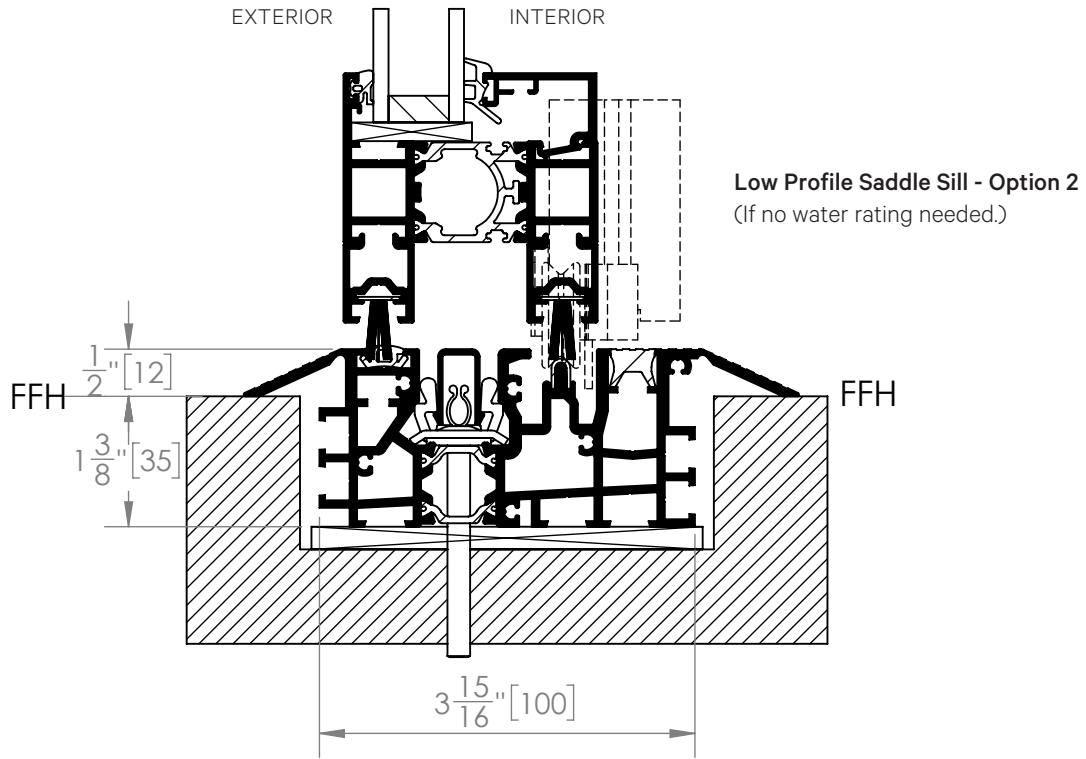

Inward Opening Details

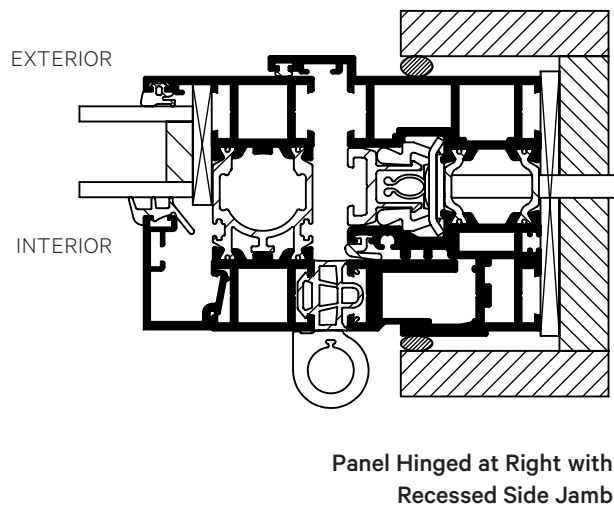
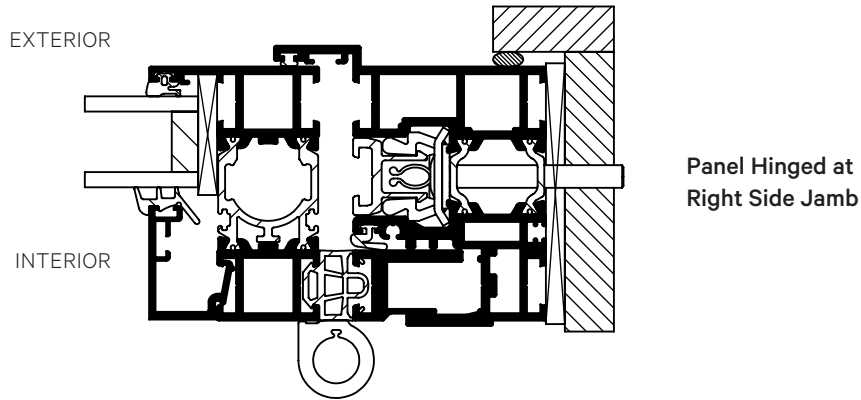

Outward Opening Details

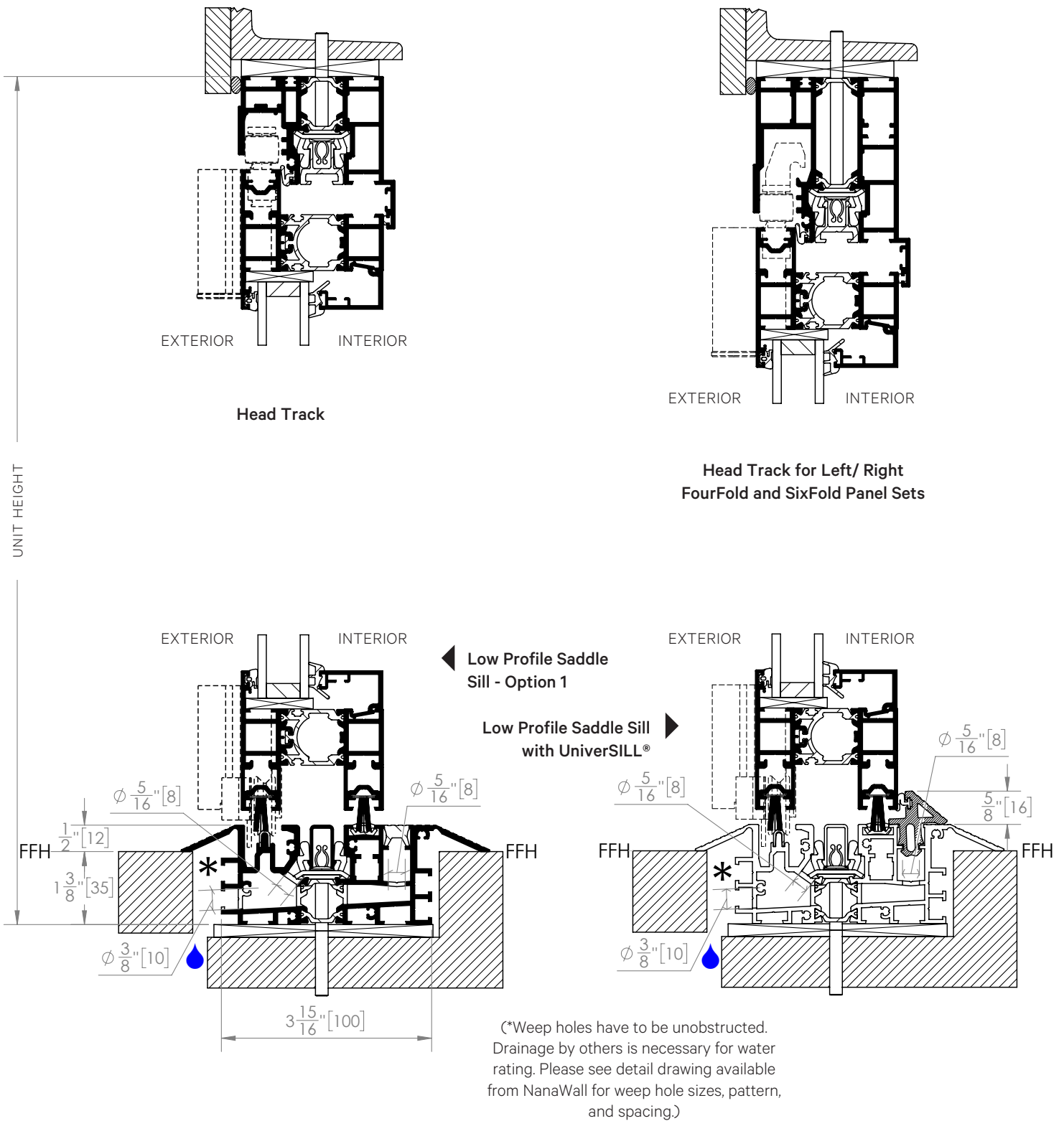

Outward Opening Details

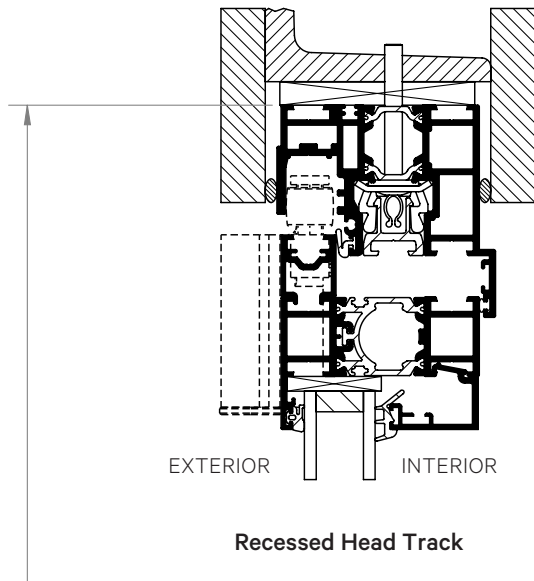

Recessed Head Track

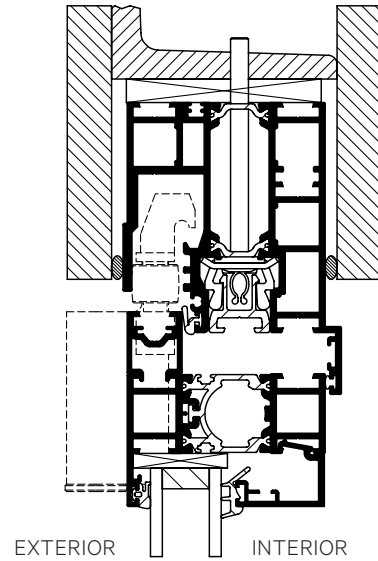

Recessed Head Track for Left/Right FourFold and SixFold Panel Sets

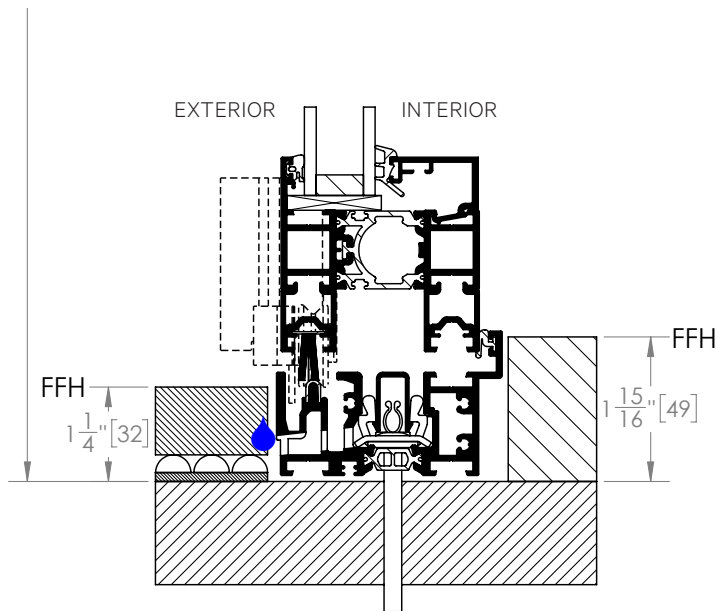

Performance Sill

(Weep slots have to be unobstructed. Details of the management of water exiting the weep slots must be designed and installed by others.)

Outward Opening Details

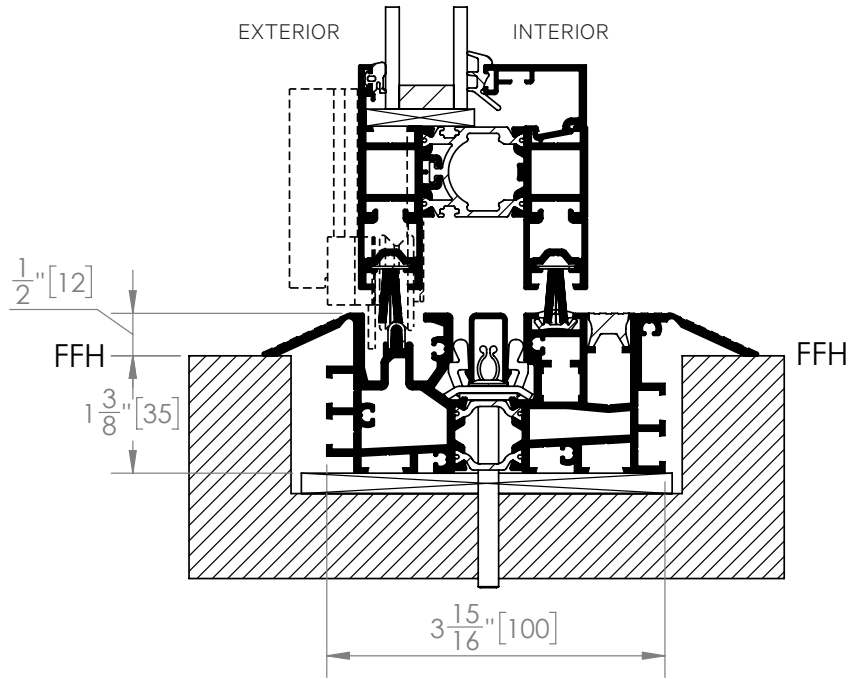

Low Profile Saddle Sill - Option 2
(If no water rating needed.)

Outward Opening Details

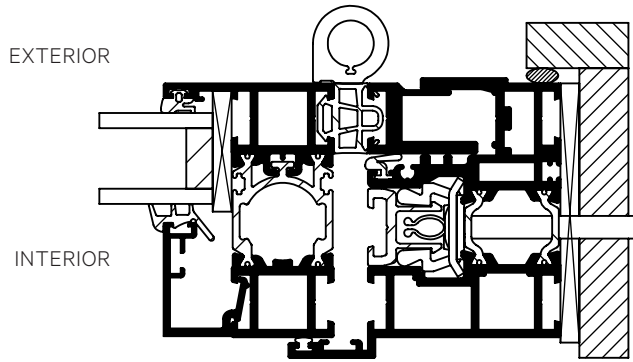

Panel Hinged at
Right Side Jamb

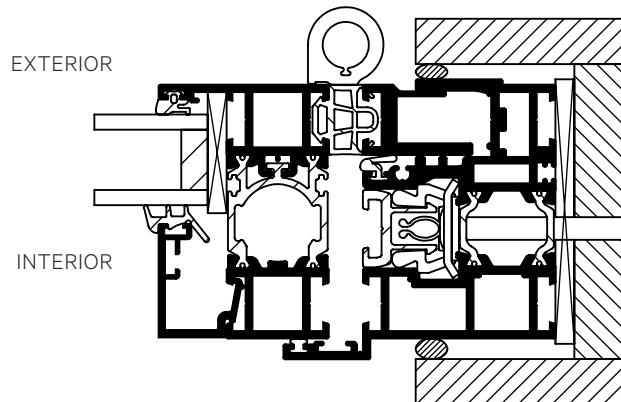

Panel Hinged at Right
with Recessed Side Jamb