

NanaWall HSW60 - Thermally Broken Aluminum Framed Single Track Sliding System

Introduction	1
Engineering Details.....	4
Performance and Testing Results	5
Design Windload Chart.....	8
Maximum Frame Size Chart	9
Possible Stacking Options and Configurations	12
Section Details	17
Suggested Typical Installation	24



NanaWall HSW60 The Thermally Broken Aluminum Framed Single Track Sliding System

Unique Features

The thermally broken aluminum framed NanaWall HSW60 is an exterior, weather-resistant single track sliding system that provides the ultimate in versatility and flexibility. This is a storefront and entrance system that can easily and efficiently slide with a minimum of force completely out-of-sight when desired, offering designers new possibilities for large, exterior opening glass walls. To see these operable wall concepts in action, please visit www.nanawall.com and click on the "Configuration" link on the HSW60 page.

For benefits of all NanaWall systems, see the "General Introduction" section. For common features and a comparison between aluminum individual panel systems, see the "Sliding Glass Walls" page.

Sizes

Unit heights of up to 12' (3650 mm) and panel widths of up to 5' (1525 mm) are possible.

No horizontal mullion needed for unit heights of up to 10' 6" (3200 mm).

Incorporated swing panel with panel heights of up to 9' 2" (2800 mm) possible, with many choices on position of incorporated swing panels in the opening and designed for use as a "normal" commercial egress door.

Single Hand Easy Operation In/Out of Stacking Bay

With an intelligent guide system, most panels self-guide through the switches for easy operation and stacking using sintered Bronze Carrier rollers and guided switches.

Incorporated Swing Entry/Exit Panel(s)

If desired, almost every sliding panel in the closed position can be converted and be used as an incorporated single acting swing panel. A pair of incorporated swing panels allows the possibility that either panel can be opened first. Swing panels can open inward or outward. The incorporated entrance doors have been engineered for "normal" commercial traffic and have been independently tested to half a million opening and closing cycles per AAMA 920.

High Weather Resistance

The HSW60 is engineered to provide high weather resistance and structural performance. Excellent independent testing

results were achieved per AAMA/WDMA/CSA 101/I.S.2/A440 standards with a unit height of 10' and panel width of 3' achieving a DP rating per ASTM E-331 of +/- 45 psf. See "Performance and Testing Results" for further details.

Florida Approval

The HSW60 has received statewide Florida approval with Product Approval number 37259. This information with limitations can be viewed at www.floridabuilding.org.

Floor Track Optional

For certain applications, sills can be eliminated completely – providing seamless transition between two spaces. Locking rods in panels engage in adjustable floor sockets.

Multiple Stacking Options

The sliding storefront can be completely out-of-sight during business hours. The tracks can be laid out beyond the frame in a variety of configurations, and the stacking bays can be positioned anywhere along the track. The two carrier suspension system permits the use of track with right-angle turns and segmented curves, allowing multiple options for space set-up and remote storage.

Multiple Space Set-up

Using the same panels with additional parallel and perpendicular tracks will expand or reduce heated or air conditioned spaces with ease and convenience.

Right Turns and Segmented Curved Walls

With an ingenious, variable angle astragal profile, systems can be supplied with any segmented angle between 0° and 90° between panels, allowing the designer to create completely open corners or bays. Panels can turn corners.

Design Flexibility

Individual panels can be designed with different widths, glazing choices (double and triple insulated glass, laminated glass, etc.) and muntin layouts (horizontal mullions, SDLs, solid panels, higher bottom rails, etc.).

NFRC Rated Thermal Performance

The HSW60 has been rated, certified, and labeled in accordance with NFRC 100 and NFRC 200; see the “Performance and Testing Results” section for more details.

Superior Thermal Break

Panels thermally broken with a 7/8" (22 mm) polyamide plastic reinforced with glass fibers. This thermal barrier provides increased strength, superior humidity control, improved acoustics, and energy savings with better U-values.

Acoustical Performance

The HSW60 system has been tested by an independent acoustic lab for acoustical performance. A standard unit (no incorporated swing panel) with STC 46 special laminated glass achieved STC and Rw values of 43 with the head track recessed and 41 with the head track exposed. See “Acoustical Performance” page for STC test results with other glass.

General Description

The HSW60 is a thermally broken, aluminum framed single track sliding system, designed to provide an opening glass wall or storefront with any custom panel size within the limitation of the Maximum Size Chart. Different panel widths are possible with additional tracks in the stacking bay for the different widths. Sliding panels convertible to incorporated swing entry/exit panel(s) are possible. An end panel can be a swing panel hinged to a side jamb. Swing panels are single acting but can be either inward or outward opening. Possible configurations and stacking bay options are virtually limitless (see drawings for some possibilities).

Frames

The nominal head jamb thickness is 2 9/16" (65 mm). Optional cover plates on both sides can be provided. The nominal side jamb thickness is 2 3/8" (60 mm) extruded aluminum thermally broken with a 7/8" (22 mm) wide polyamide plastic. All pins and screws to assemble the frame are provided. Various sill options, including a no sill option with floor sockets only, are available. The stacking bay and the upper track leading to the stacking bay are the same profile as the head jamb.

Panels

The stiles and rails of all panels are extruded aluminum, 2 3/8" (60 mm) thick and thermally broken with a 7/8" (22 mm) wide polyamide plastic; see cross-section drawings. Standard finishes available are 50 powder coated finishes as shown in the NanaWall Color Chart and in clear anodized. 25 of these colors are available in both glossy and semi-glossy (matte) finishes. Other various custom finishes are also available. Different finishes are also possible on interior and exterior sides; see “Aluminum Finish Options” in the General Introduction.

Panels are pre-assembled and panel stiles and rails are connected by special zinc die cast alloy, thermally broken corner fittings that incorporate carriers, hinge components, and male and female locking receptacles. The finish for corner connectors is the closest powder coat match to the finish of frame and panels.

Incorporated swing panel pivot side stiles utilize a special circular profile that also doubles as storage for a crank handle that is used to convert panel from sliding panel to swing panel and vice versa.

Glazing

Units can be supplied glazed with 15/16"-1 1/8" clear double insulating safety, 15/16"-1 1/8" double insulating Low-E safety, 1 1/2" triple insulating glass, 1/4" single tempered glass, other high performing safety glass such as special acoustic glass, special tint, etc. or other glass on request.

See “Glazing” in the General Introduction for other glass thickness possible.

Weatherstripping

Double APTK weatherstripping is provided for vertical sealing between panels and between panels and frames; brush seals with flexible plastic web are provided for all horizontal sealing and for vertical sealing at pivot stiles of incorporated swing panels; see cross-section drawings.

Sliding Hardware

For sliding panels, two load-bearing unidirectional carriers are attached to the upper corners of each panel. Each carrier has one glide-roller and two-three horizontal counter-rotating wheels that roll in the track. Each wheel is made from sintered bronze (oil impregnated) that is self-lubricating and is attached to the panels with stainless steel rods. Carriers can easily negotiate square or angled corners.

Swing Panel Hardware

For Incorporated swing panels, the top rail consists of two parts - an upper arm with similar unidirectional carriers as on sliding panels and the actual top rail of the swing panel. This top rail can be detached from the upper arm for conversion from a sliding panel function to a swing panel function and vice versa. Conversion from a sliding panel to a swing panel and vice versa is accomplished by turning the flat handle 180° and by operation with a crank handle of the Conversion box located on the upper arm.

For swing panels that are attached to a side jamb, a commercial grade clear or dark bronze anodized hinges are attached.

Locking Hardware and Handle Options

On sliding panels and swing panels attached to a side jamb, a two-point locking hardware is provided as needed, consisting of top and bottom locking rods operated by a 180° turn of a flat handle on the inside only. The top rod interlocks the male locking receptacle with the female receptacle of the adjacent panel or engages into the head track. The lower rod is thrown into a designated striker plate. The pivot side of incorporated swing panels are provided with the same locking with the lower rod engaging into a designated strike plate.

For incorporated swing panels and swing panel(s) attached to the side jamb, there are the following additional hardware options:

1. Lever Handle Operation. Consisting of standard lever handles on the inside and outside, a lockset, a lockable latch, deadbolt and rods at the top and bottom. After unlocking with turn of key or thumbturn, depression of handles withdraws all locking points and latch. Lifting of handles engages rods and turn of key or thumbturn engages deadbolt and locks. Available with profile cylinder or with SFIC adapter.

2. Push/Pull Handle Operation. Consisting of push/pull handles on both sides with deadbolt(s) operated by a lockset. Turn of key or thumb turn operates lock. Lockset option of having key operation on both sides. To keep the panel closed when unlocked, a door closer can be supplied.

3. Panic Hardware Operation. For panic hardware to be supplied and installed by others, outward opening swing panels can be supplied with no locking hardware, but as support for the panic bar and to hide the back side of the panic bar, a horizontal mullion is provided.

For a unit with no swing panel, an option to enable a unit to be opened from the outside is to provide on the sliding panel to be opened first: Two-point locking hardware consisting of

top and bottom Polyamide capped locking rods operated by a 180° turn of a L-shaped handle on the inside and lockable with a thumbturn or a flat handle on the inside and lockable with a key. In both cases, there will be an L-shaped/flat handle on the outside that is lockable with a key. Please note that locking from the inside with a key may not meet egress requirements.

Handle Finish Schemes:

Standard - Stainless steel lever, flat, and L-shaped handles in brushed satin or black titanium finish.

Optional - Lever and flat handle available in anti-viral/anti-microbial copper nickel finish. Brass lever handles in oil rubbed, satin nickel, or white finish and flat handles closest powdercoat match to panel aluminum finish.

Push/pull handles are in brushed stainless steel finish.

HSW60 Engineering Details



Tight Weather Seal
End-to-end closure with interlocking profiles and heavy duty double siliconized EPDM gaskets provide a tight, draft, and rattle-free weather seal.

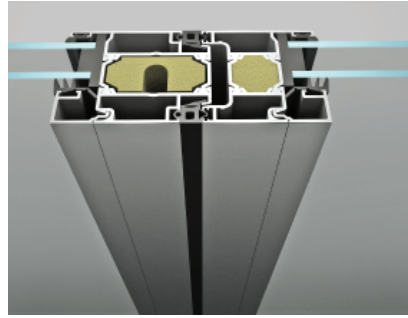

Superior Energy Performance
Multi-chamber thermally efficient aluminum profiles include a foam core. This 15/16" (24 mm) polyamide thermal barrier provides increased strength, superior humidity control, and acoustic attenuation. The thermally efficient sills minimize inside condensation.

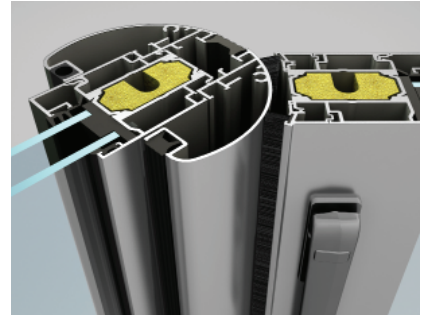

Patented Pinch Protection
The entrance doors are equipped with rounded profiles to provide pinch protection during opening and closing.

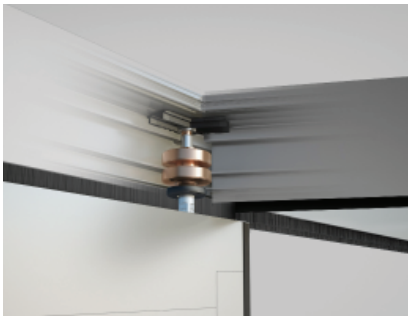

Trouble-Free Operation
The unique "intelligent" rollers and guide technology ensures easy, single hand trouble-free operation of panels into the stacking bays. The self-lubricated, oil-infused, bronze rollers with ball bearings and stainless steel axles are engineered for longevity.



Main Entrance Doors Can Move Away
If desired, every sliding panel can include an incorporated single acting swing panel with an overhead door closer.

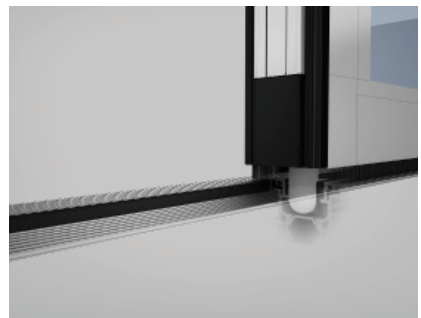

Security
Concealed multi-point locking operates with the turn of a handle. Convenient one-handed operation shoots the concealed lockbolt up to engage the hook receiver of the adjacent panel and down to secure the panel to the floor track for a multi-point secure connection. The bottom shoot bolt has a full one-inch throw for maximum security.







Clean Lines
The innovative profile conceals the entrance door conversion locking rods. All accessories are integrated into the system for clean lines. The locking system is easy to operate with one hand.



Elegant and Durable Hardware
The stainless steel lever handles and pull handles are durable and ensure easy operation of the entry/exit panel. Other handle shapes and finishes are available.

HSW60

TYPE OF TEST	RESULTS			
 <p>Air Infiltration ^① ASTM E-283, cfm/ft²</p>	<p>@ 1.6 psf (75 Pa): 0.30 (1.5 L/s/m²)</p>			
 <p>Water Penetration ^① ASTM E-547 and ASTM E-331 <i>(With low profile saddle sill only.)</i></p>	<p>Unit with weep holes from inner channel: No uncontrolled water entry @ 6 psf (290 Pa)</p> <p>Subject to the following adaptations of the sill in the field by others:</p> <ol style="list-style-type: none"> 1. Remove the gaskets covering the inner channel. 2. Drill weep holes through the bottom of this channel (about one 3/8" weep hole per panel). 3. Drill weep holes through the lower front face of the sill to the inner channel bottom (about 3/8" weep hole per panel). <p>Please note that due to varying site requirements and conditions, these sills will not be prepared for drainage by NanaWall Systems, Inc. If this drainage system is desired, we recommend that a qualified professional construct this system on the project site that is strictly in accordance with instructions provided by NanaWall and in accordance with good waterproofing techniques. If drain connections are not made, or are not possible, unit may leak with wind driven rain.</p>			
 <p>Structural Load Deflection ^① ASTM E-330: pass See Design Windload Charts for other sized panels <i>Note that the structural test pressures were 50% higher than the design pressures.</i></p>	<p style="text-align: center;">DESIGN PRESSURE</p> <table style="width: 100%; border-collapse: collapse;"> <tr> <td style="width: 50%; text-align: center; vertical-align: middle;"> Positive @ 45 psf (2160 Pa) </td> <td style="width: 10%; text-align: center; vertical-align: middle;"> </td> <td style="width: 40%; text-align: center; vertical-align: middle;"> Negative @ 45 psf (2160 Pa) </td> </tr> </table> <p>For saddle sill specimen above, class SP-PG40 (weep holes by others), panel size - 3' 1" x 9' 5" (940 mm x 2870 mm) ^②</p>	Positive @ 45 psf (2160 Pa)		Negative @ 45 psf (2160 Pa)
Positive @ 45 psf (2160 Pa)		Negative @ 45 psf (2160 Pa)		
 <p>Forced Entry Resistance ^① ASTM F842</p>	<p>Type A. Grade: 40 Pass</p>			
 <p>Life Cycle Performance AAMA 920</p>	<p>For incorporated swing panel 500,000 cycles - pass</p>			

^① Excerpts of results of a 6 panel unit tested by Architectural Testing, Inc., an independent testing laboratory, in October 2010 per AAMA/WDMA/CSA 101/IS.2/A440 Fenestration Standard (NAFS). Unit was 18' 1/2" W x 10' H with a total of 6 panels consisting of a half swing panel attached to the side jamb, 3 sliding panels and 2 incorporated swing panels. All locking was standard and sill was low profile saddle sill.

^② For Canada, tested to NAFS-08 or equivalent and CSA A44051-09.

Check www.NanaWall.com for the latest updates.

HSW60



Thermal Performance

Rated, certified and labeled in accordance with NFRC 100 and NFRC 200

TYPE OF GLASS (1 LITE) ^④	CENTER OF GLASS U-FACTOR	GLASS THICKNESS	STANDARD SILL				LOW PROFILE SADDLE SILL				SOCKETS ONLY			
			UNIT U-FACTOR	SHGC ^⑤	VT ^⑥	2015 ENERGY STAR	UNIT U-FACTOR	SHGC ^⑤	VT ^⑥	2015 ENERGY STAR	UNIT U-FACTOR	SHGC ^⑤	VT ^⑥	2015 ENERGY STAR
Double IG Clear (air filled)	.48	15/16" (24 mm)	.49	.50	.54	-	.50	.50	.53	-	.50	.50	.53	-
Double IG Standard Low E (argon filled)	.26	15/16" (24 mm)	.34	.23	.46	-	.34	.23	.46	-	.34	.23	.46	-
Double IG Standard Low E (air filled)	.30	15/16" (24 mm)	.37	.23	.47	-	.37	.23	.46	-	.37	.23	.46	-
Triple IG Low E x 2 (argon filled)	.13	1 7/16" (38 mm)	.25	.20	.36	*	.25	.20	.36	*	.25	.20	.36	*
Triple IG Low E x 2 (air filled)	.16	1 7/16" (38 mm)	.27	.20	.36	*	.28	.20	.36	*	.28	.20	.36	*
1/4" single clear	1.02	1/4" (6 mm)	.84	.55	.59	-	.85	.55	.58	-	.84	.55	.58	-

NOTES

④ NFRC simulated U factors of units with a horizontal mullion will have values of .01 to .03 higher than units with no horizontal mullion. Please contact NanaWall for details.

⑤ SHGC = Solar Heat Gain Coefficient
 ⑥ VT = Visible Transmittance

* A 2015 Energy Star Qualification Criteria: U-Factor for doors in all climate zones <.30, Shgc <.25 in South/South central zones and <.40 in North/North Central zones. (For guidance only. NanaWall is not a participant of the Energy Star program.)

Values shown are for limited select glass types only. Call NanaWall for U-Factor & SHGC for other glass types

HSW60

TYPE OF TEST	RESULTS
 <p>Acoustical Performance ^{①②}</p>	STC (Rw) 33 and OITC 27 achieved with STC 32 glass (1 5/16" [24 mm] double IGU, 4 mm tempered + 4 mm tempered) ^①
	STC 37 (Rw 38) and OITC 31 achieved with STC 41 glass (1 5/16" [34 mm] double IGU, 8 mm laminated + 6 mm tempered) ^①
	STC (Rw) 41 achieved with STC 46 glass (1 9/16" [40 mm] double IGU, 8 mm laminated + 8 mm tempered) ^②
	STC (Rw) 43 achieved with STC 46 glass (1 9/16" [40 mm] double IGU, 8 mm laminated + 8 mm tempered) with head track recessed ^②

① Excerpts of results of a three panel unit 9' 10" W x 8' 2" H (3000 mm x 2500 mm) tested in August 2019 by SG Bauakustik, Muelheim an der Ruhr, Germany, an EN DIN ISO accredited and certified independent testing laboratory.

② Excerpts of results of four panel unit with swing panel attached to the side jamb 13' 7" W x 8' 8" H (4140 mm x 2640 mm) tested in December 2011 by Nusing Mobile Trennwandtechnik, Munster, Germany, an accredited and certified independent testing laboratory.

Check www.NanaWall.com for the latest updates.

Acoustical Performance Interpolation with Other Glazing Options

TYPE OF GLASS	GLASS ONLY STC	COMPLETE SYSTEM STC (Rw)	MAXIMUM UNIT HEIGHT POSSIBLE (*)
1/4" (6 mm) tempered	31	32	12' 0" (3650 mm)
1/4" (6 mm) laminated	35	35	12' 0" (3650 mm)
3/8" (10 mm) laminated	38	36	12' 0" (3650 mm)
1 7/16" (36 mm) double IGU, 6 mm laminated + 6 mm laminated	42	38	12' 0" (3650 mm)
1 5/8" (42 mm) double IGU, 8 mm enhanced laminated + 8 mm enhanced laminated	47	41	12' 0" (3650 mm)
1 5/8" (42 mm) double IGU, 8 mm enhanced laminated + 8 mm enhanced laminated	47	43 (with head track recessed)	12' 0" (3650 mm)

NOTES

(*) Does not apply if there is an incorporated swing door.

Contact NanaWall for other glass types.

Both Positive and Negative Design Pressures
 (In Accordance with Allowable Stress Design (ASD) Design Pressures*)

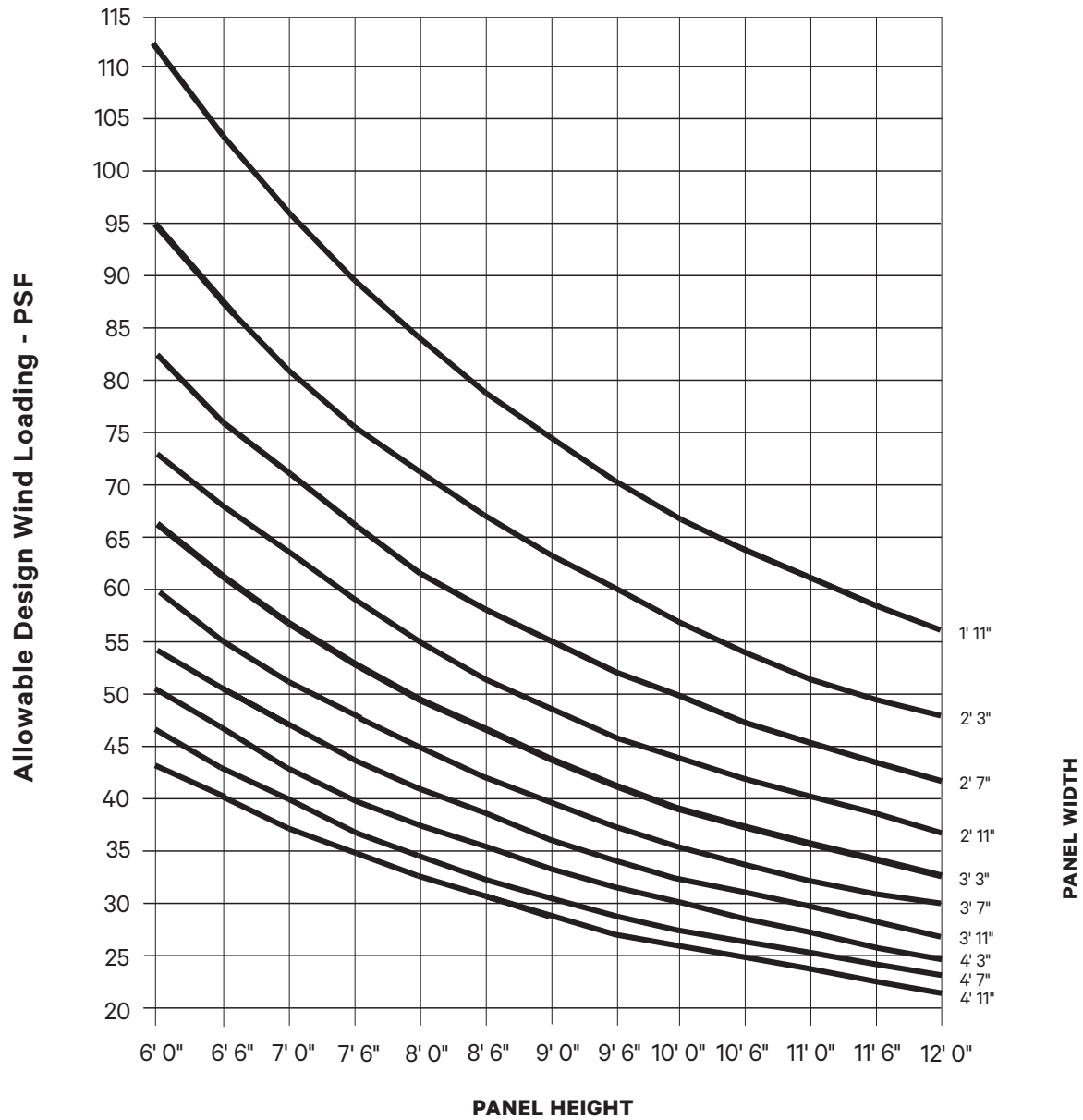

See Maximum Frame Size Chart for Possible Sizes.

(Derived from Comparative Analysis) Test Panel Size: 37" W x 113" H.

Please note that some jurisdictions may limit the use of these charts or may not accept them at all. Design pressures and/or sizes may be restricted to what was tested. This chart is only applicable for units with referenced NanaWall supplied locking.

* If the project design pressures have been calculated in accordance with Ultimate Design Wind Speed (ULT), then these design pressures have to be multiplied by a factor of 0.6 to obtain the equivalent ASD design pressures shown in this chart.

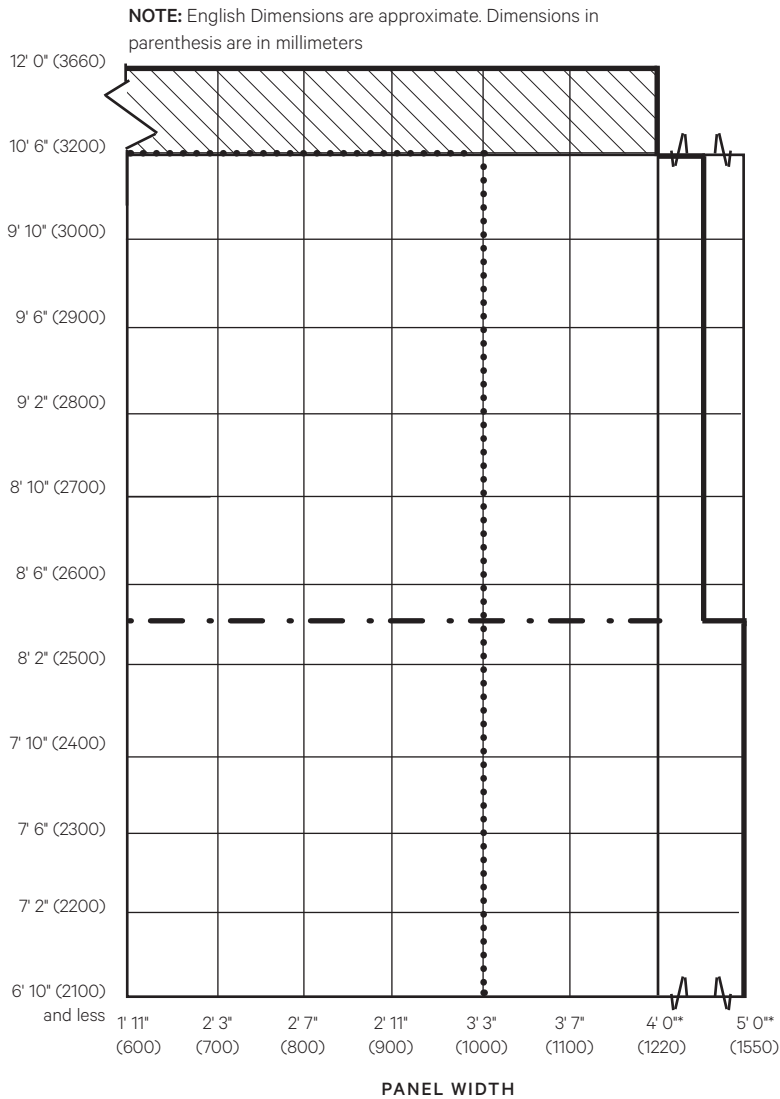

The number of panels possible in a system is unlimited.

Any custom panel size is possible up to the maximum size shown.

——— : Indicates maximum unit height and width of a **sliding panel**. Note the chart shows maximum unit height, not panel height.

..... : Indicates maximum unit height and width of a **swing panel**.

• — • — : For triple glazed panels for heights above 8' 4" (2550 mm) a horizontal mullion is needed, located such that no glass pane height is more than 7' 10" (2400 mm). 10' (3050 mm) is also maximum height for triple glazed units.

▨ On chart indicates that for single and double glazed panels a horizontal mullion is needed located such that no glass panel height is more than 7' 10" (2400 mm). The total number of panels in a unit is only restricted by structural steel consideration.

The maximum size limits are based on the weight of a panel that has a net glass thickness of 1/2" or 12 mm for heights up to 10' 6" (3200 mm) and panel widths up to 4' (1220 mm) and net glass thickness of 5/16" (8 mm) for heights above 10' 6" (3200 mm) or panel widths of more than 4'. If thicker net glass is used on a panel, this maximum size chart will not apply. Please consult with NanaWall.

Each application is different so please consult with NanaWall on possibilities.

The unit width is the panel width multiplied by the number of panels.

Generally, the minimum width of each sliding panel is 1' 11" (600 mm) and the minimum incorporated swing panel width is 2' 7" (800 mm).

* For panel widths wider than 4' 0" (1220 mm) and less than 5' 0" (1550 mm), there are the following limitations:

1. Only certain stacking concepts are possible. Please check with NanaWall.
2. A horizontal mullion is needed for unit heights greater than 8' 4" (2550 mm).
3. Triple glazed panels are not possible.

Interior Size Chart HSW60: STC 32 to STC 38

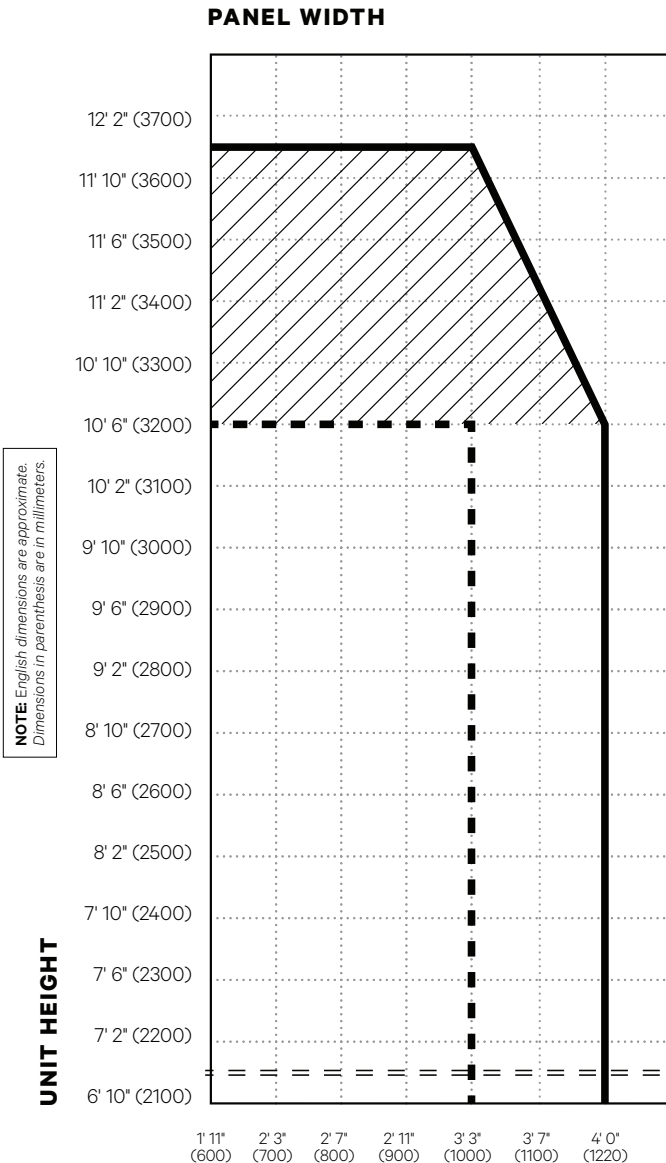

 Indicates that a horizontal mullion is needed located such that no glass panel height is more than 10' 6" (3200 mm)

The number of panels possible in a system is unlimited.

Any custom panel size is possible up to the maximum size shown.

 Indicates maximum unit height and width of a sliding panel. Note the chart shows maximum unit height, not panel height.

 Indicates maximum unit height and width of a swing panel at the side jamb and incorporated swing panel (ISP). *

**using an ISP within the unit is estimated to reduce the overall sound performance of the system by about 3 STC points.*

The total number of panels in a unit is only restricted by structural steel consideration.

NOTES

- The maximum size limits are based on the weight of a panel that has a net glass thickness of 1/2" or 12 mm (6 lbs/ft 2 - 30 kg). If thicker net glass is used on a panel, this maximum size chart will not apply. Please consult with NanaWall.
- Each application is different so please consult with NanaWall on possibilities.
- The unit width is the panel width multiplied by the number of panels.
- Generally, the minimum width of each sliding panel is 1' 11" (600 mm) and the minimum incorporated swing panel (ISP) width is 2' 7" (800 mm).
- ISP is a swing panel within the system that converts to a sliding panel.
- Higher sized panels (over 10' 6" [3200 mm] in height) may need to be operated by more than one person.

Interior Size Chart HSW60: STC 41 and STC 43

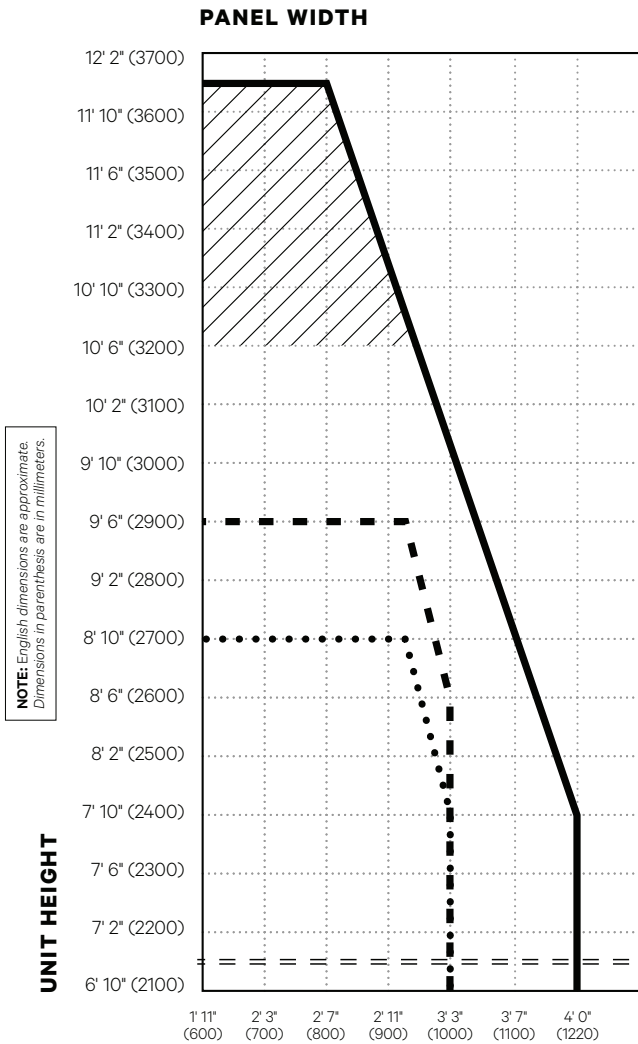



STC 43 is achieved with the head track recessed.
 STC 41 is achieved without the head track recessed.

 Indicates that a horizontal mullion is needed located such that no glass panel height is more than 10' 6" (3200 mm)

The number of panels possible in a system is unlimited.

Any custom panel size is possible up to the maximum size shown.

 Indicates maximum unit height and width of a sliding panel. Note the chart shows maximum unit height, not panel height.

 Indicates maximum unit height and width of a swing panel hinged to side jamb.

 Indicates maximum unit height and width of an incorporated swing panel (ISP). *

**using an ISP within the unit is estimated to reduce the overall sound performance of the system by about 3 STC points.*

The total number of panels in a unit is only restricted by structural steel consideration.

NOTES

- The maximum size limits are based on the weight of a panel that has a net glass thickness of 5/8" (16 mm) 8 lbs/ft² (40 kg/m²). If thicker net glass is used on a panel, this maximum size chart will not apply. Please consult with NanaWall.
- Each application is different so please consult with NanaWall on possibilities.
- The unit width is the panel width multiplied by the number of panels.
- Generally, the minimum width of each sliding panel is 1' 11" (600 mm) and the minimum incorporated swing panel ISP width is 2' 7" (800 mm).
- ISP is a swing panel within the system that converts to a sliding panel.
- Higher sized panels (over 10' 2" [3100 mm] in height) may need to be operated by more than one person.

Elevation drawings and plan views of typical possible stacking concepts. Please see referenced cross-section details. As there can be many other stacking possibilities, please submit your ideas and sketches to NanaWall Systems, Inc. for evaluation. If needed, NanaWall Systems can provide a 3D Conceptual Drawing to help in the design / development process. **Please note that the number of panels in a system are unlimited.**

Incorporated swing panels can be placed almost anywhere in the opening. Only a few examples are shown below.

A switch is defined as a break in the upper track at the head jamb to lead panels away from the opening to the stacking bay.

Concept A (1)

Perpendicular stacking in opening with end swing panel. Also see Concept O, which is similar but with no end swing panel.

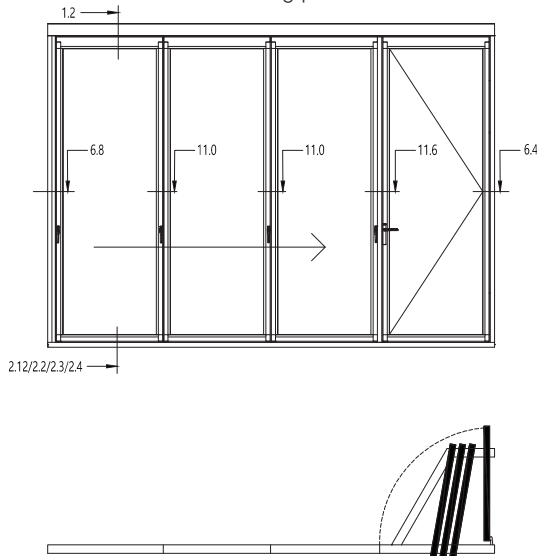

Concept B (2)

Parallel remote stacking. See also Concepts L, M, and N for variations.

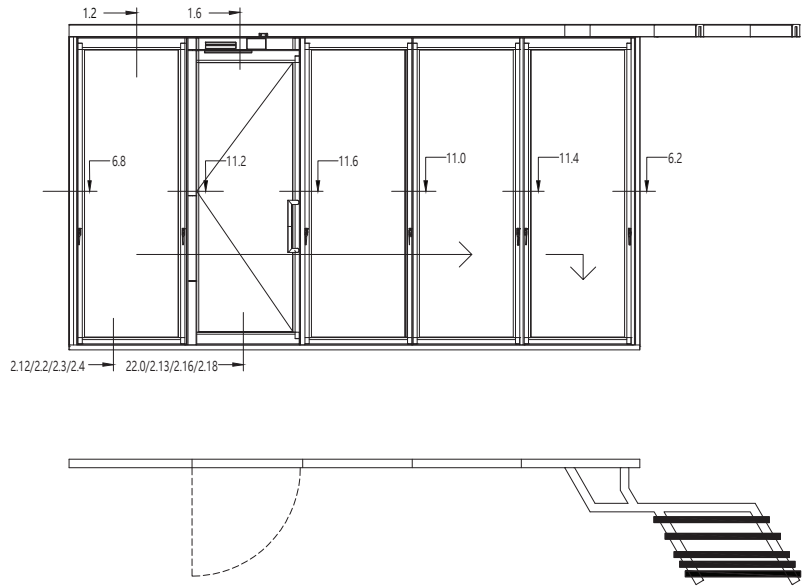

Concept C (3)

Parallel stacking with an extended track. Unit is offset from the wall opening. See also Concepts D & F for variations.

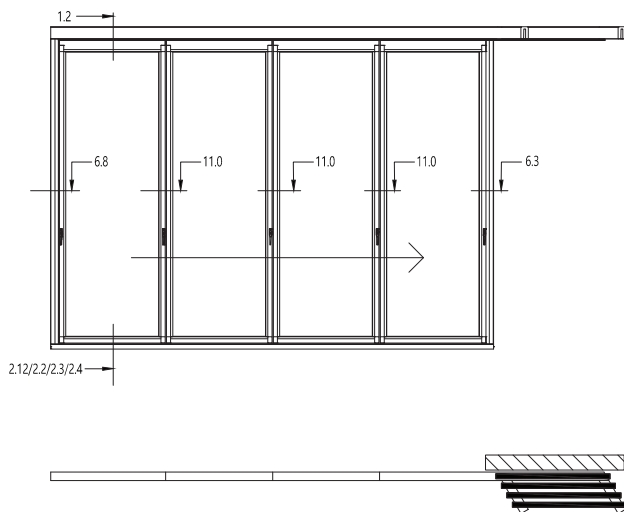

Concept D

Extended track for first panel and remote parallel stacking for other panels to allow for swing panel hardware to clear wall. Unit is offset from the wall opening. See Concepts C & F for variations.

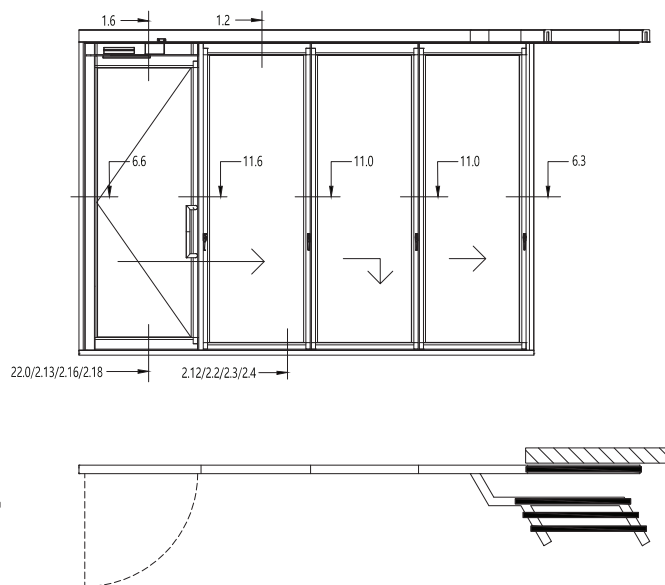

Concept E

Remote parallel stacking with end swing panel opened completely. See Concept G for variation.

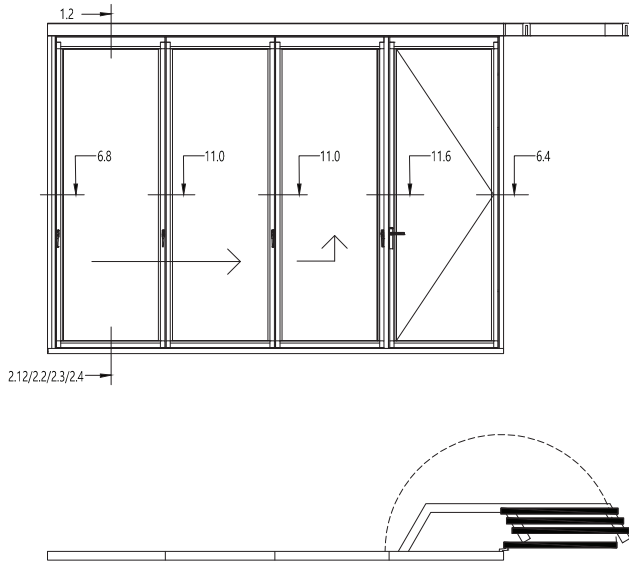

Concept F

Extended track for first panel and remote parallel stacking for other panels to allow for swing panel hardware to clear wall. Unit is offset from the wall opening. See Concepts C & D for variations.

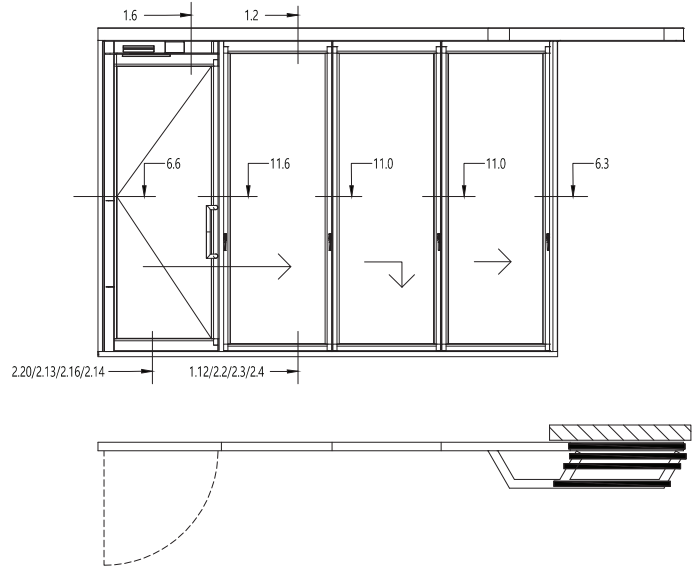

Concept G

Remote parallel stacking with end swing panel opened completely. See Concept E for variation.

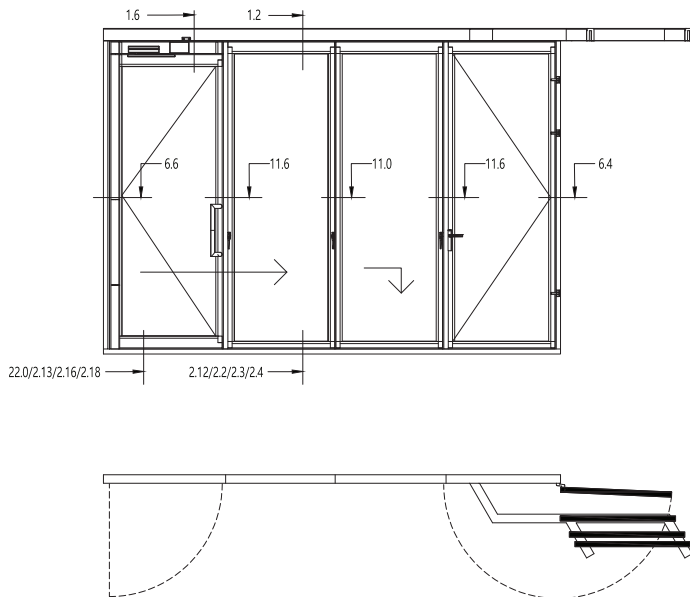

Concept H

Remote perpendicular stacking. See Concept I for variation.

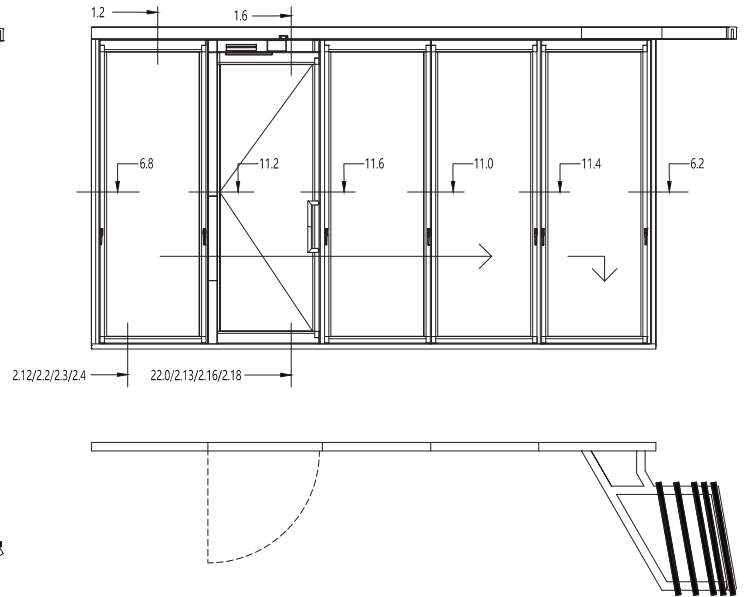

Concept I

End swing panel and remote perpendicular stacking. See Concept H for variation.

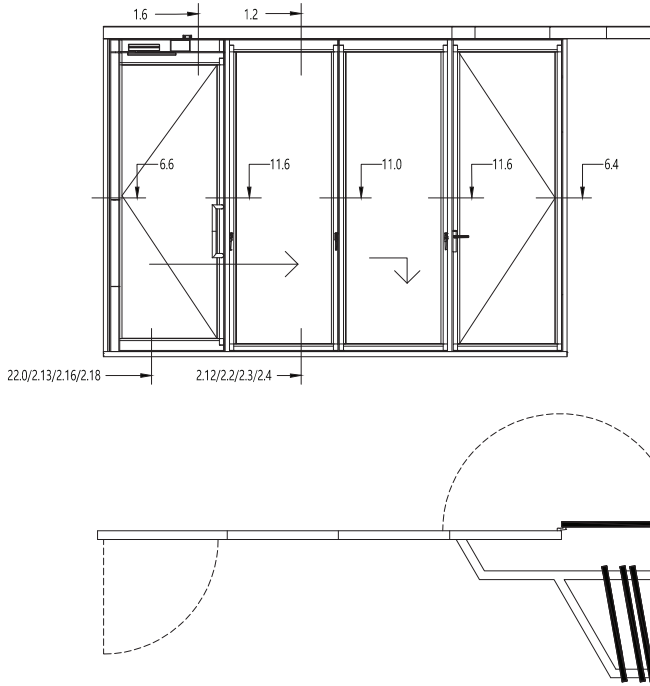

Concept J

Parallel stacking in opening with end swing panel.

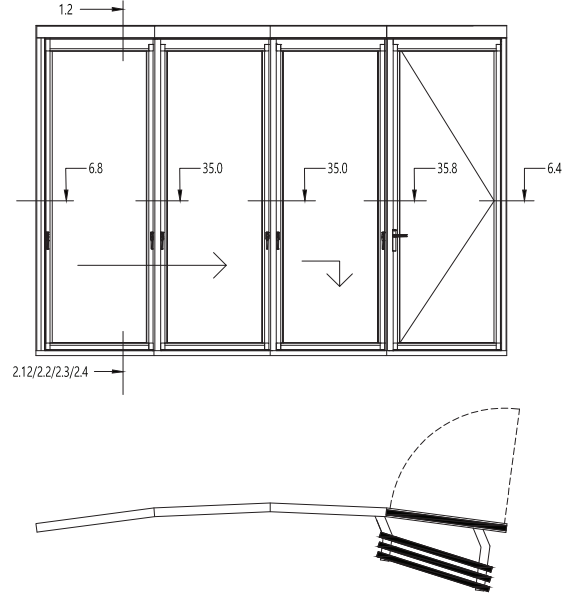

Concept K

Split stacking within opening if limited space (has no air or acoustic raiting)

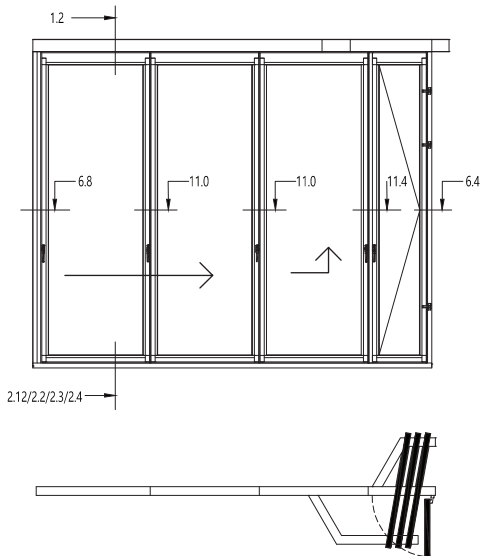

Concept L

Parallel remote stacking. See Concepts B, M, and N for variations.

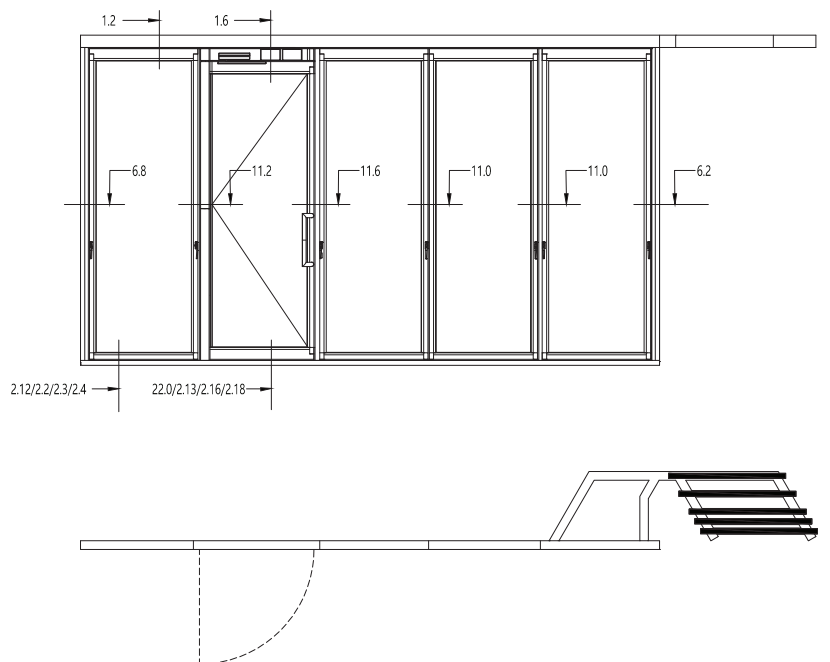

Concept M

Parallel remote stacking with stacking head track legs perpendicular to the opening. See Concepts B, L, and N for variations.

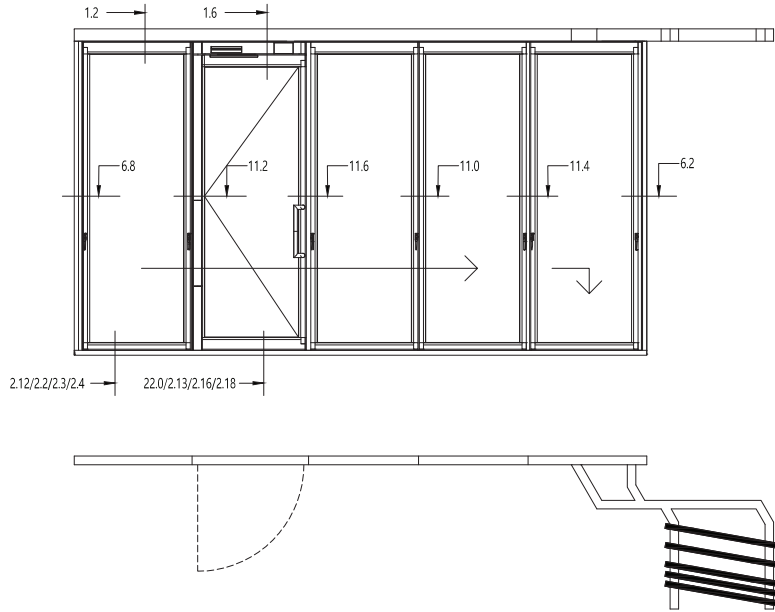

Concept N

Parallel remote stacking. See Concepts B, L, and M for variations.

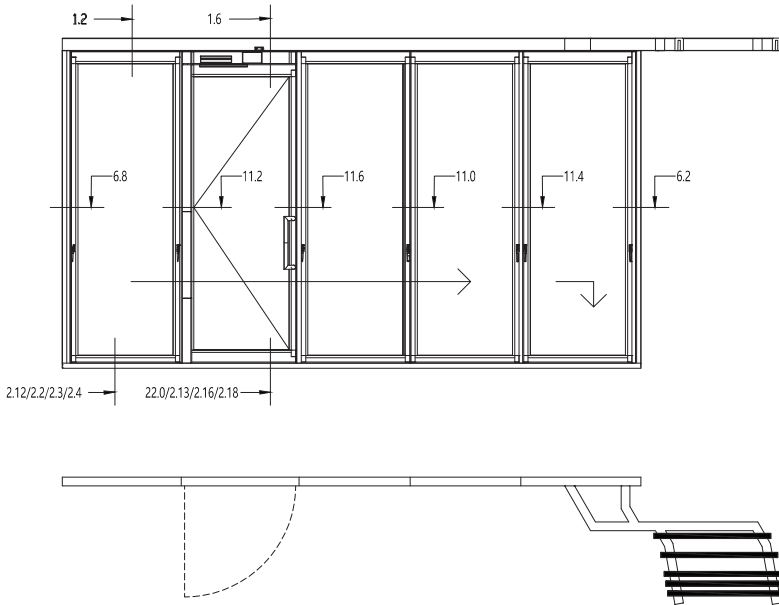

Concept O

Perpendicular stacking in opening with separate stacking track for the first panel. See Concept A for variation.

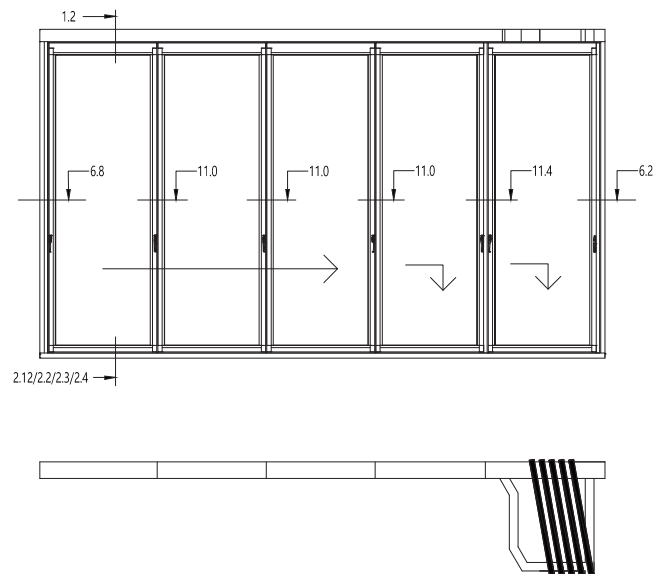

Single Track Sliding Door / Window Combination in One Unit - Without a Fixed Post Separating the Doors from the Windows (NanaWall Kitchen Transition)

The Single Track Sliding Door / Window combination opens wide, seamlessly turning a kitchen into an indoor / outdoor space. It can also be used in other types of applications. If needed, NanaWall Systems can provide a 3D Conceptual Drawing to help in the design / development process. Please note that below are examples with just three of the HSW stacking concepts. Door / Window combinations are also possible with other stacking concepts.

Please note some limitations as follows:

1. Is only possible with certain configurations and sills.
2. Lower corner where window meets door will not be as weather resistant as compared to a unit with all panels equal in height.
3. Handle heights of the door unit and window unit may be different.

Elevations looking from Inside.

Concept B-DW

Door / Window Combination Unit with remote parallel stacking.

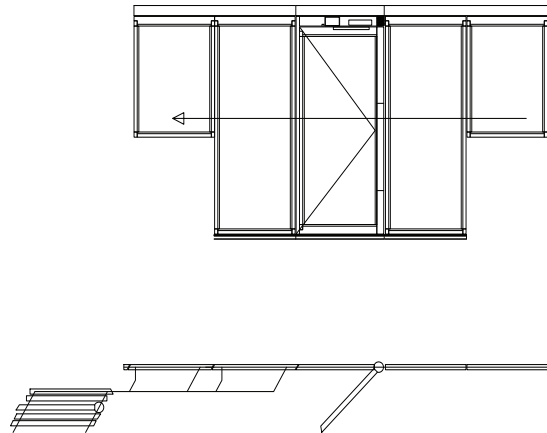

Concept J-DW

Door / Window Combination Unit with parallel stacking within the opening with end swing panel.

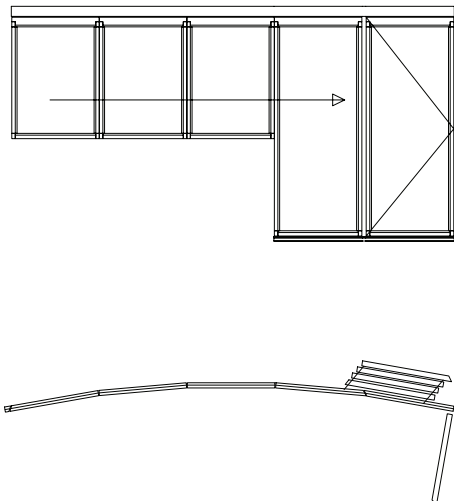

Concept O-DW

Door / Window Combination Unit with perpendicular stacking within the opening with separate stacking track for the first panel.

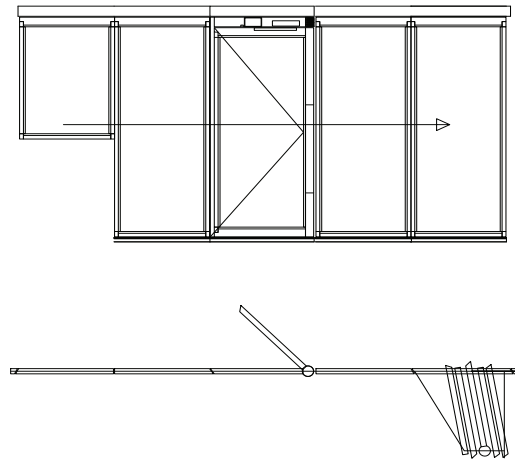

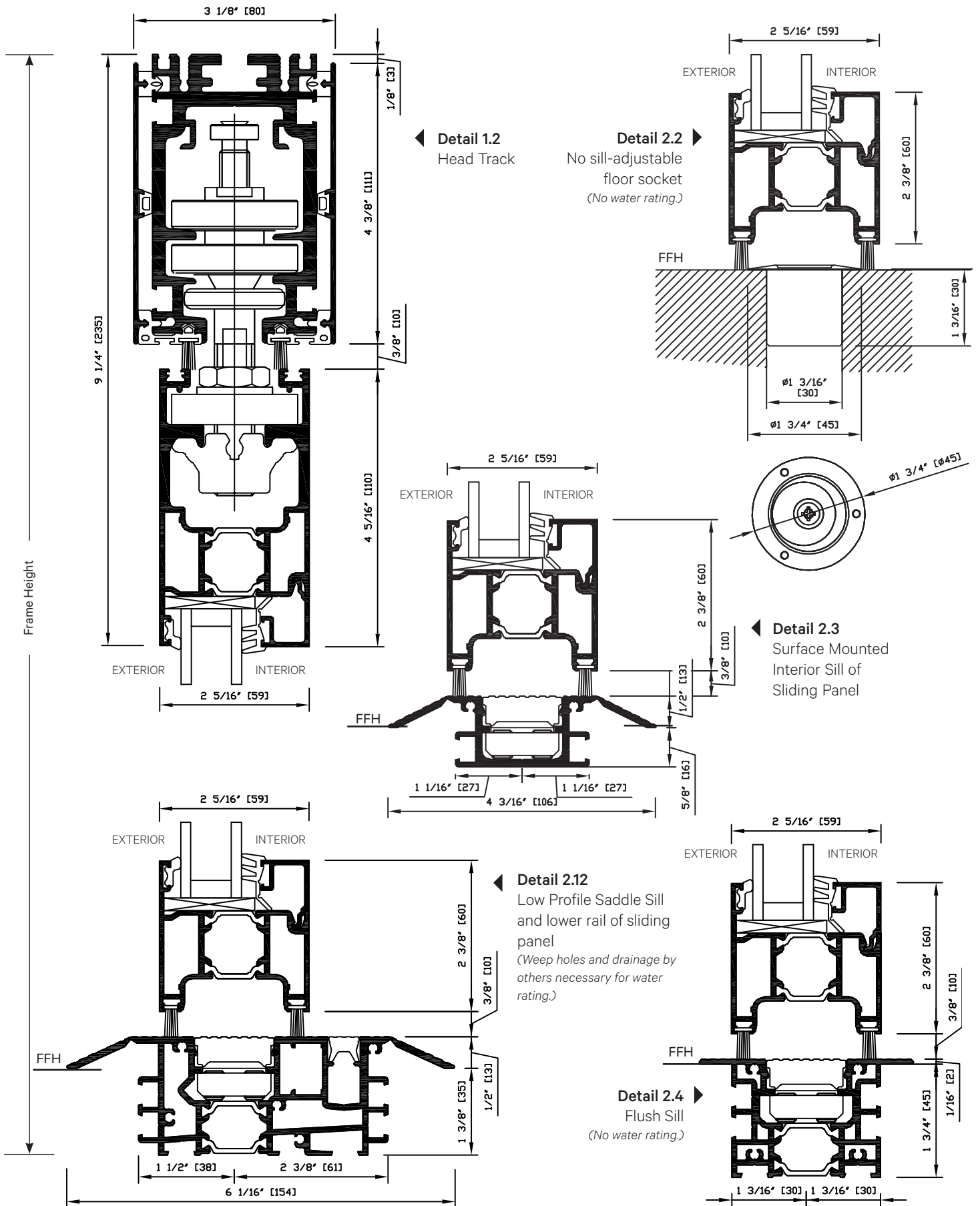

Detail 1.6 Head Track of Incorporated Swing Panel

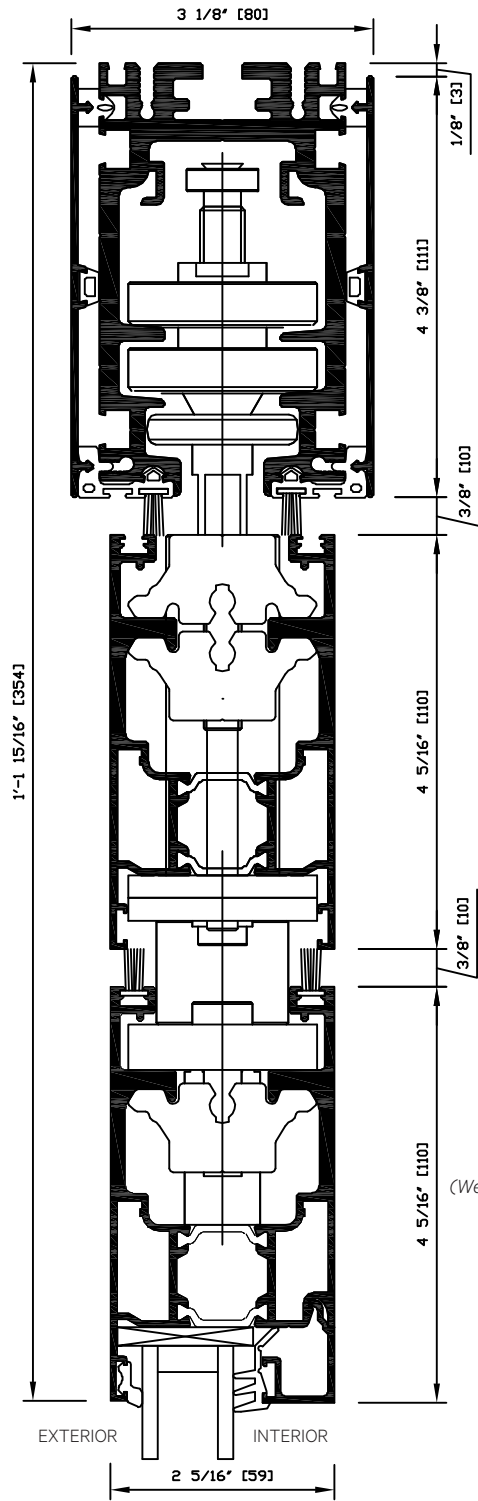

Detail 2.16 ▶
No Sill - adjustable
Floor Socket
(No water rating.)

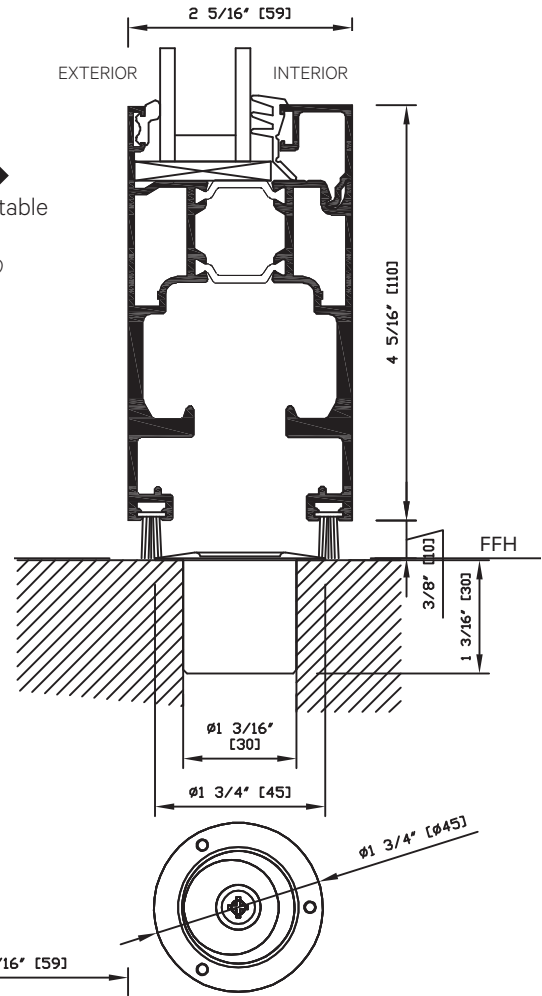

Detail 22.0 ▶
Low Profile Saddle
Sill and Lower Rail
of Incorporated
Swing Panel
(Weep holes and drainage
by others necessary
for water rating.)

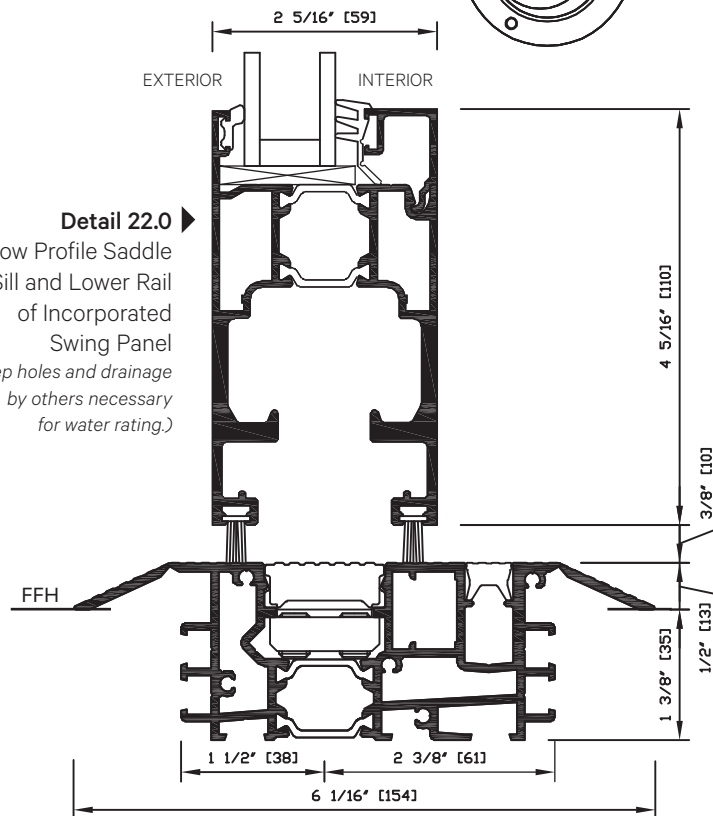

Vertical Sections for Sliding Panel with Incorporated Swing Panel

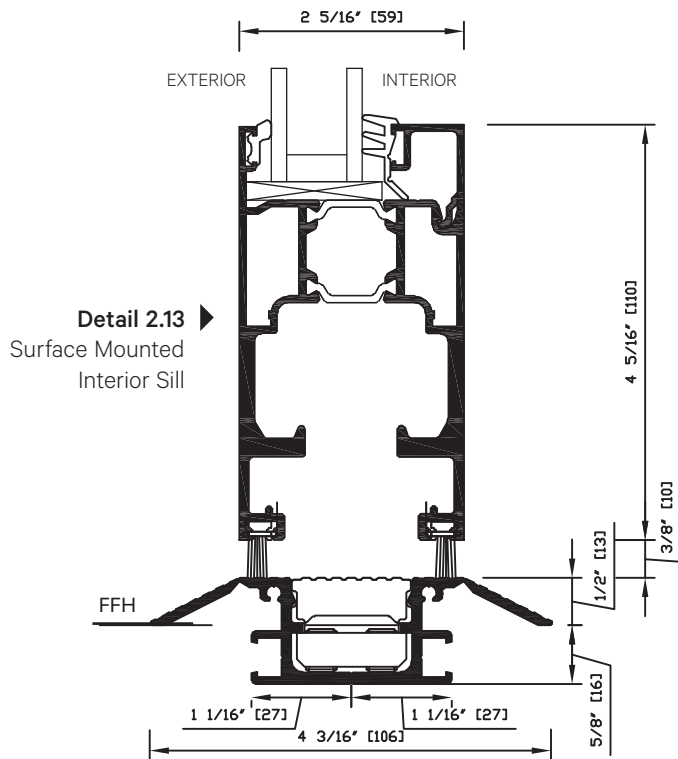
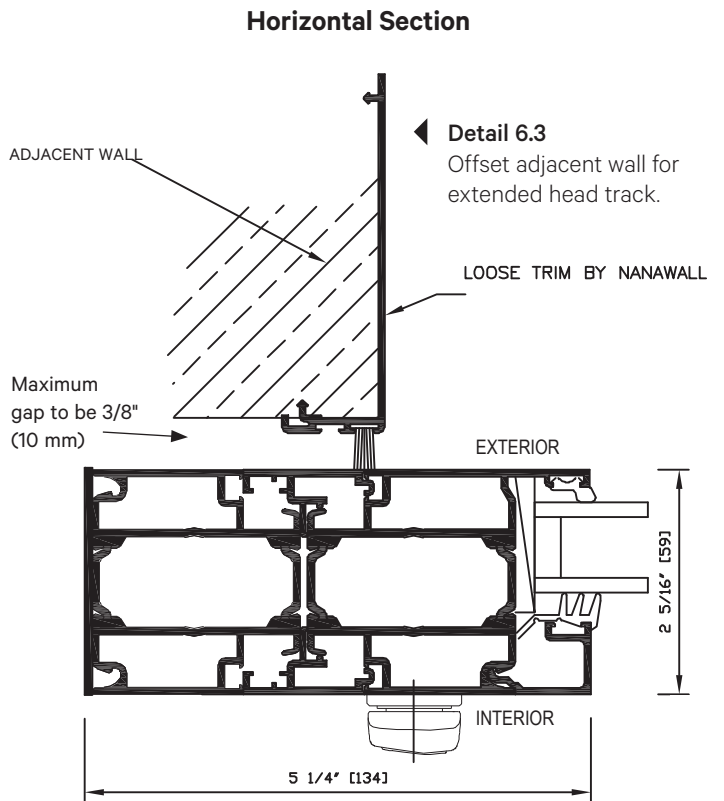
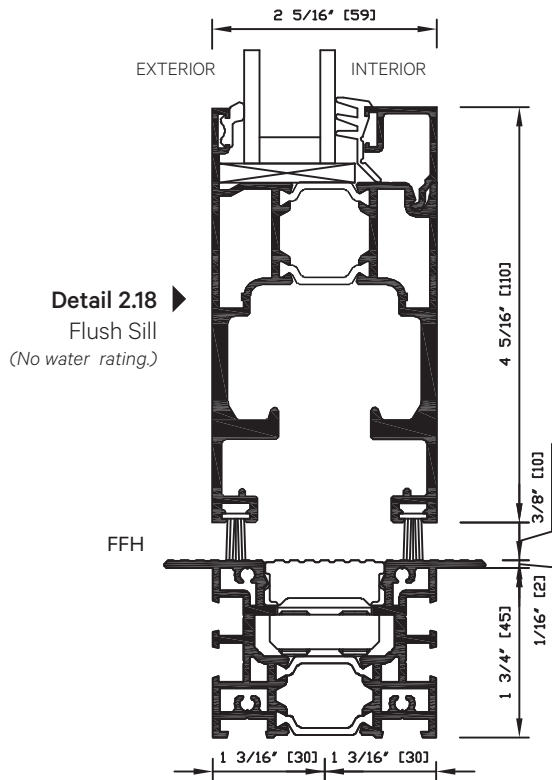

Detail 11.2
Sliding Panel meeting with hinged side of incorporated swing panel

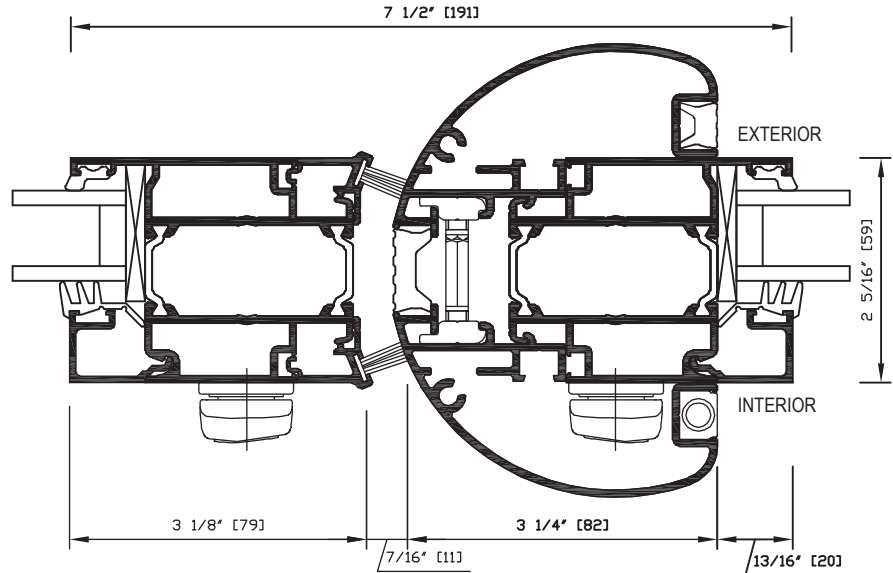

Detail 11.6
Strike side of swing panel meeting sliding panel or strike sides of a pair of swing panels meeting

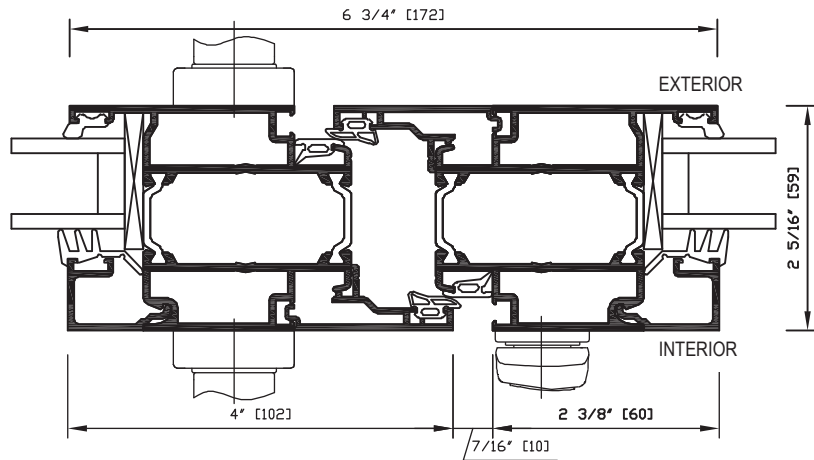

Detail 35.0
Two Sliding Panels meet at segmented angle (90° to 180°)

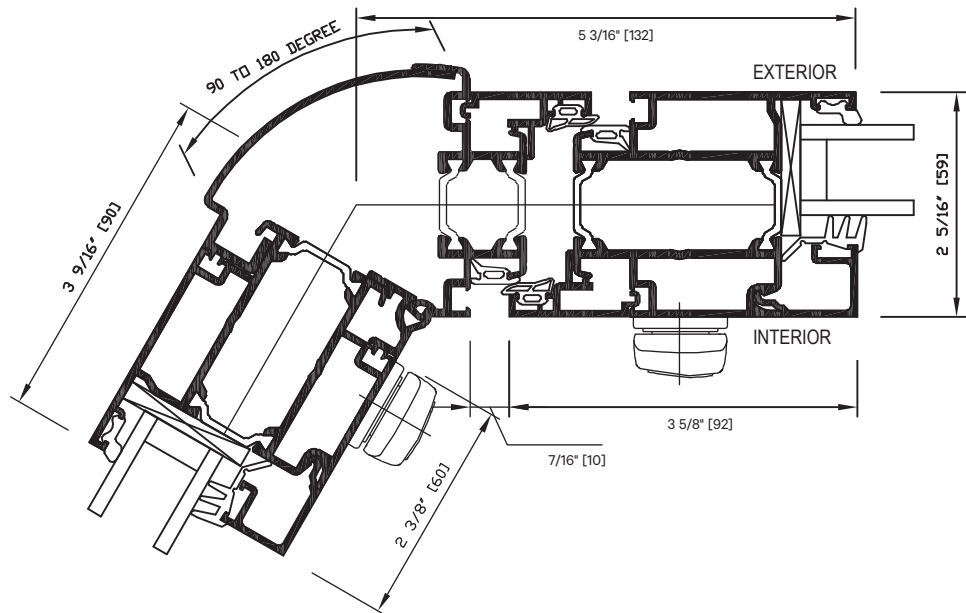

Detail 6.6

Hinge side of incorporated swing panel meeting side jamb

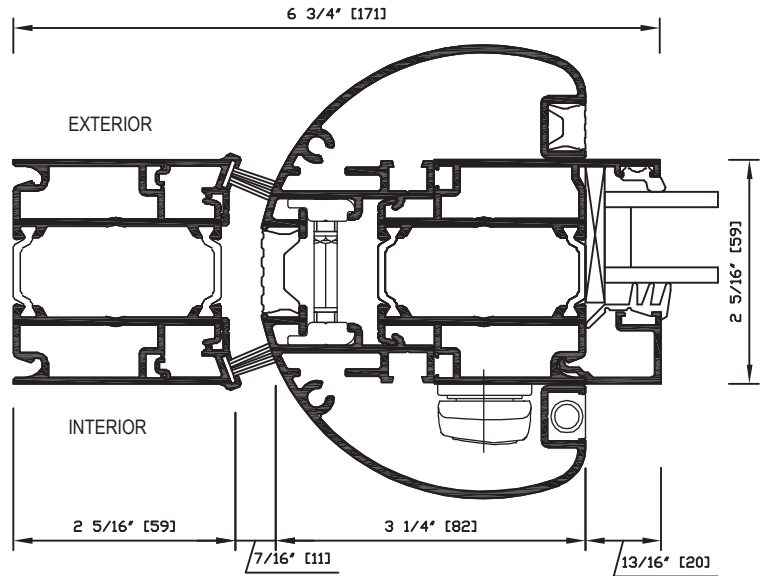

Detail 35.8

Sliding Panel meeting strike side of incorporated swing panel at segmented angle (90° to 180°). Any angle between 90° and 180° is possible.

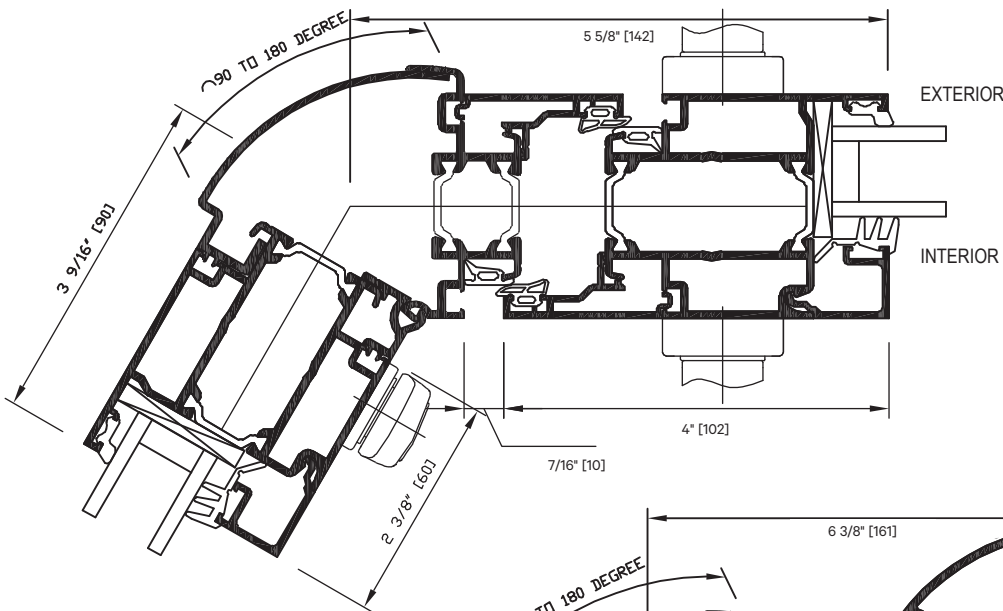

Detail 35.4

Sliding Panel meeting hinge side of incorporated swing panel at segmented angle (90° to 180°). Any angle between 90° and 180° is possible.

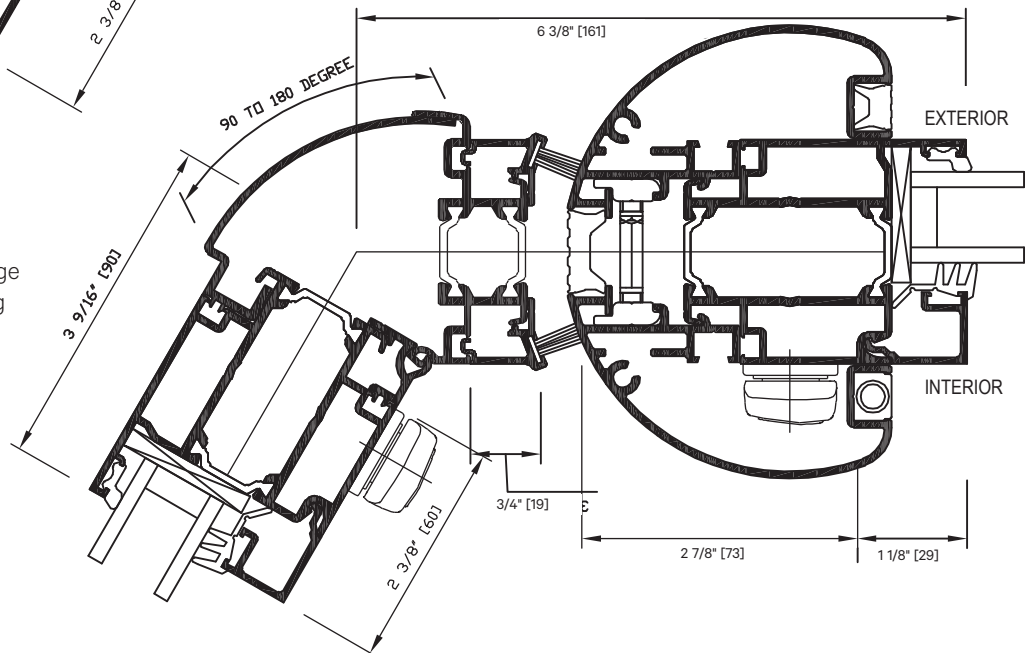

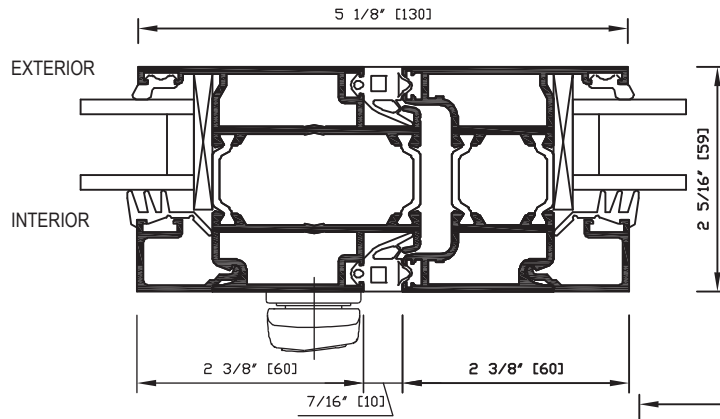

◀ **Detail 11.0**
Two Sliding Panels

Detail 11.4 ▶
Meeting of 2 panels
with locking
on both panels

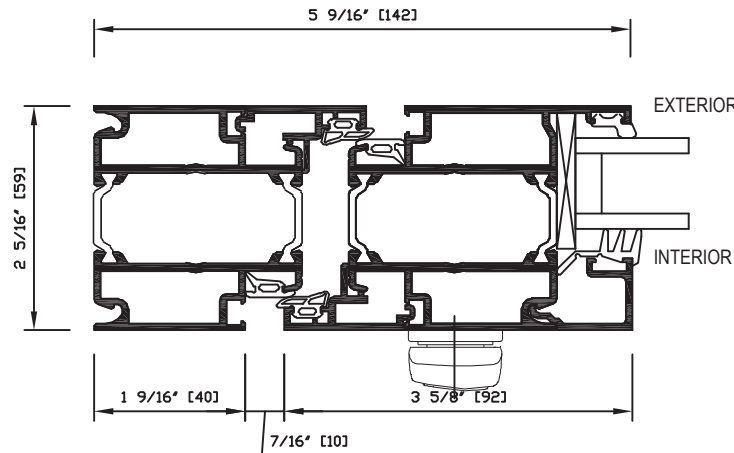
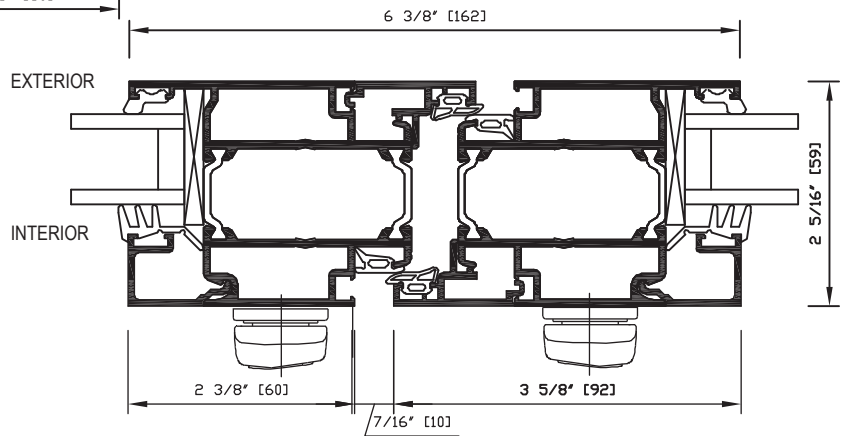

◀ **Detail 6.2**
Side jamb meeting panel.

Detail 6.4 ▶
End Swing Panel
hinged to a side
jamb.

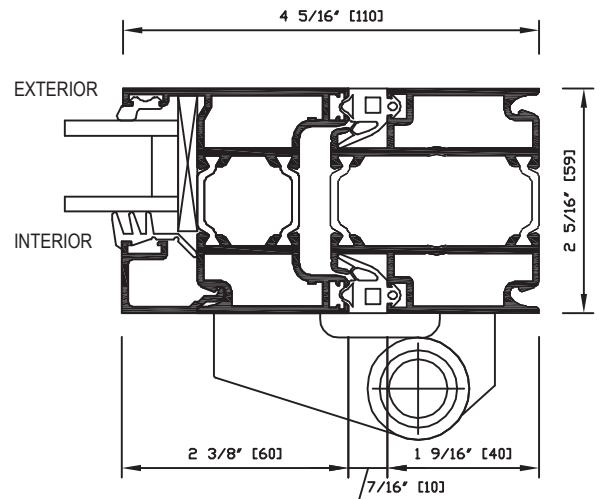

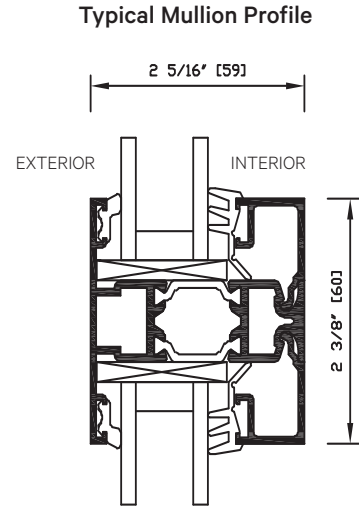
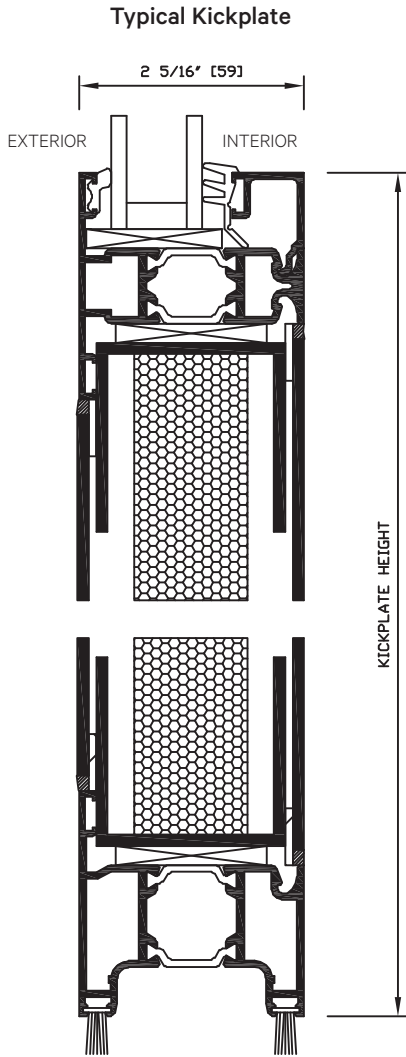

Detail 6.2
Typical Panel Profile with Single Glazing

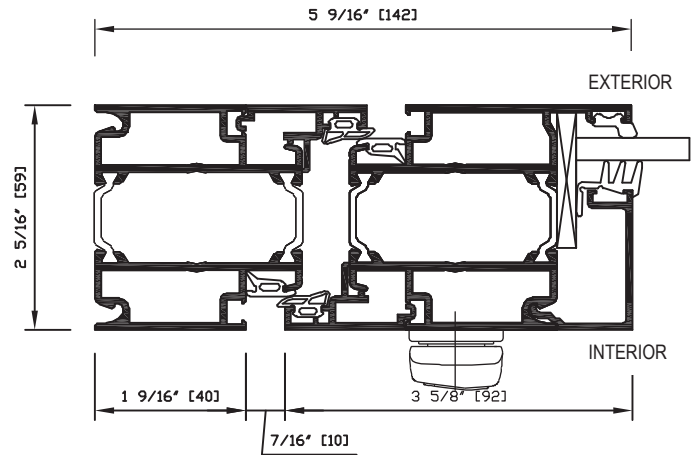

Typical Simulated Divided Lites Muntins with Spacer Between Insulated Glass (SDL)

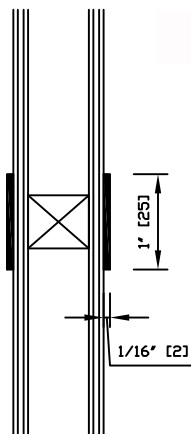

Detail 6.2 Typical Panel Profile with Triple Insulated Glazing

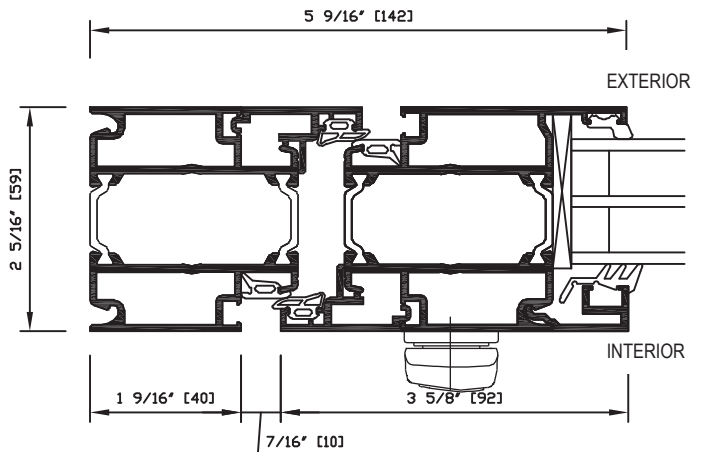

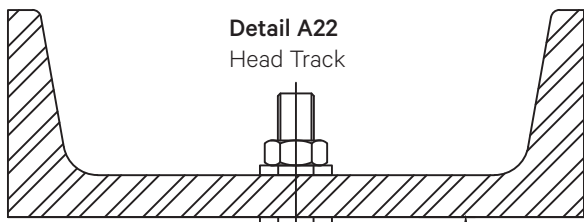

1 9/16"
[40MM]

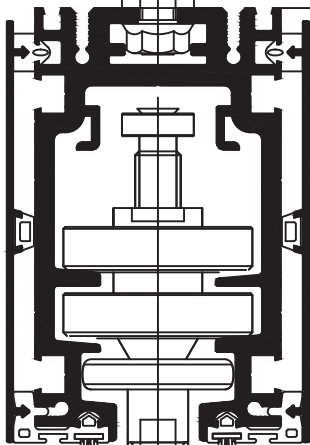

EXTERIOR

INTERIOR

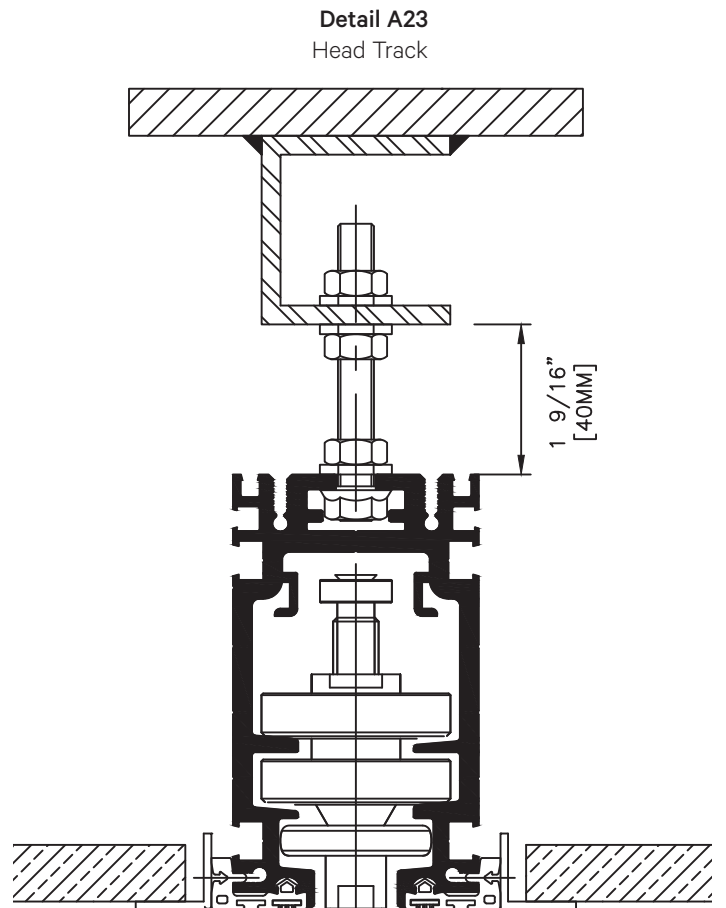

1 9/16"
[40MM]

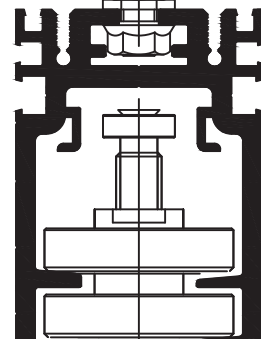

EXTERIOR

INTERIOR

EXTERIOR

INTERIOR

Panel Hinged at Right Side Jamb
(Inward Opening)

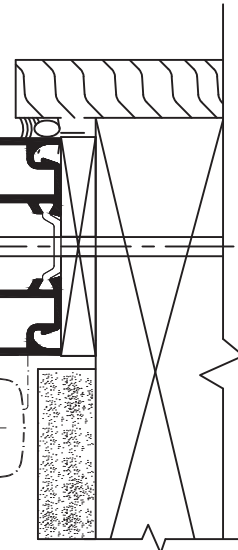

See Installation
Notes on Page 26

Detail A24

Head Track

(This detail is not recommended for larger openings or larger panels in which case the adjustable bolts in Details A22 and A23 make adjustments easier.)

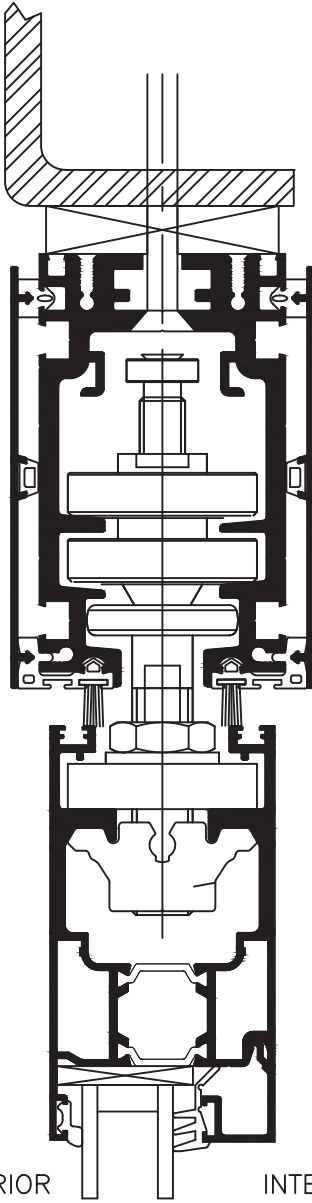

Detail A25 Head track recessed

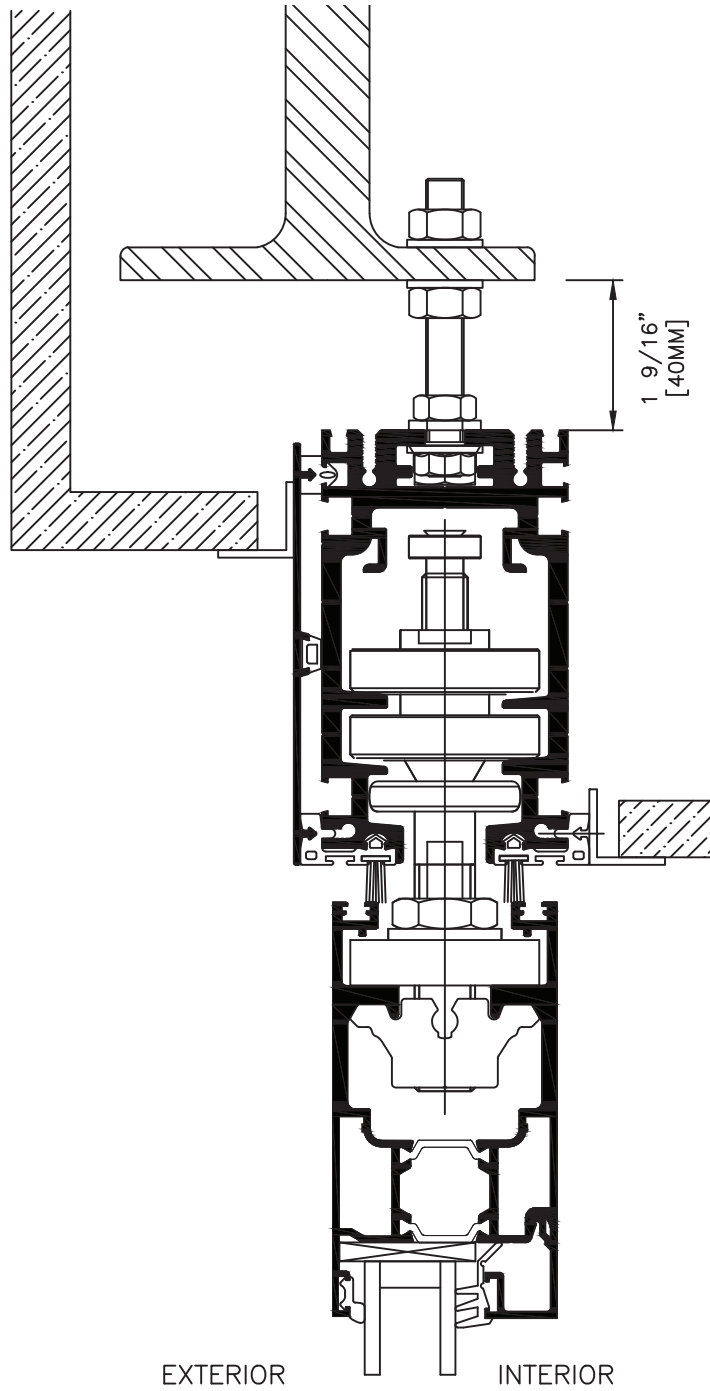

See Installation Notes on Next Page.

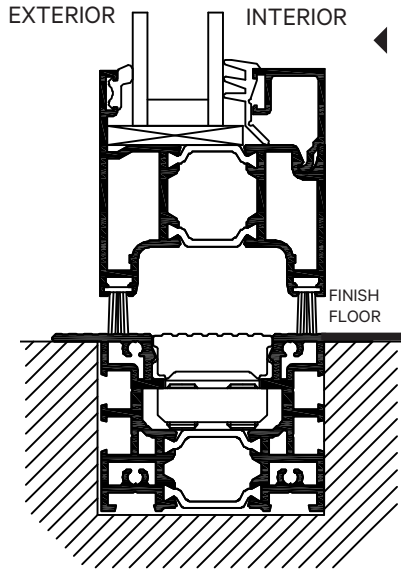

Detail 20
Flush Sill (No water rating.)

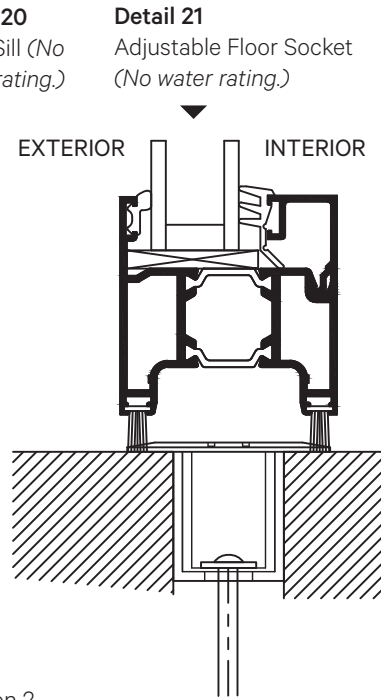

Detail 21
Adjustable Floor Socket (No water rating.)

Detail 22.2

Low Profile Saddle Sill - Option 2

(If no water rating needed. See Detail 22.1 if water rating is needed.)

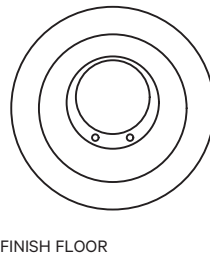
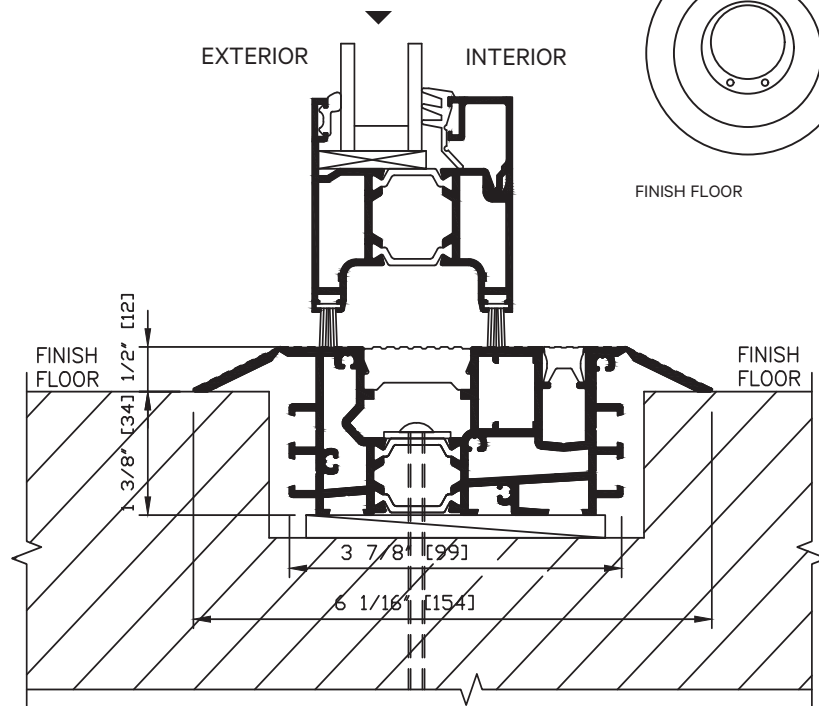

INSTALLATION NOTES

Suggested Typical Installation drawings shown are very general and may not be suitable for any particular installation. Product placement, fasteners, flashing, waterproofing, sealant, trim and other details for specific surrounding conditions must be properly designed and provided by others.

INSTALLATION CONSIDERATIONS

The approximate weight of a panel with single glazing is up to 5.25 lbs/ft² (25 kg/m²) (3/8" or 10 mm), double and triple glazing up to 8.25 lbs/ft² (40 kgs/m²) (5/8" or 16 mm net thick glass) respectively. The maximum vertical structural deflection of the header should be the lesser of L/720 of the span and 1/4" (6 mm) under full live and dead loads. The structural support for lateral loads must also be provided. See "Pre-Installation Preparation and Installation Guidelines" in the General Introduction. An owner's manual with installation instructions is available upon request. **NOTE:** Overhead structural steel support must be provided for the entire length of the track and stacking bays.

It is recommended that all building dead loads be applied to the header prior to installing the NanaWall. If so and if a reasonable amount of time has been allowed for the effect of this dead load on the header, then only the building's live load can be used to meet the above requirements of L/720 or 1/4" (6 mm). If not, both the dead and live loads need to be considered.

Detail 23 ▶

Surface Mounted Interior Sill

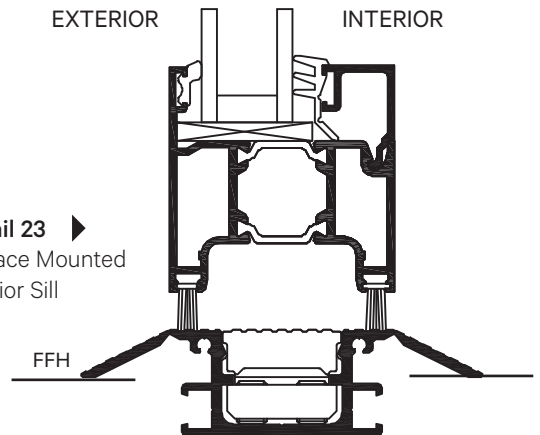

Detail 22.1

Low Profile Saddle Sill - Option 1

(Weep holes as shown below and drainage by others necessary for water rating as lab tested)

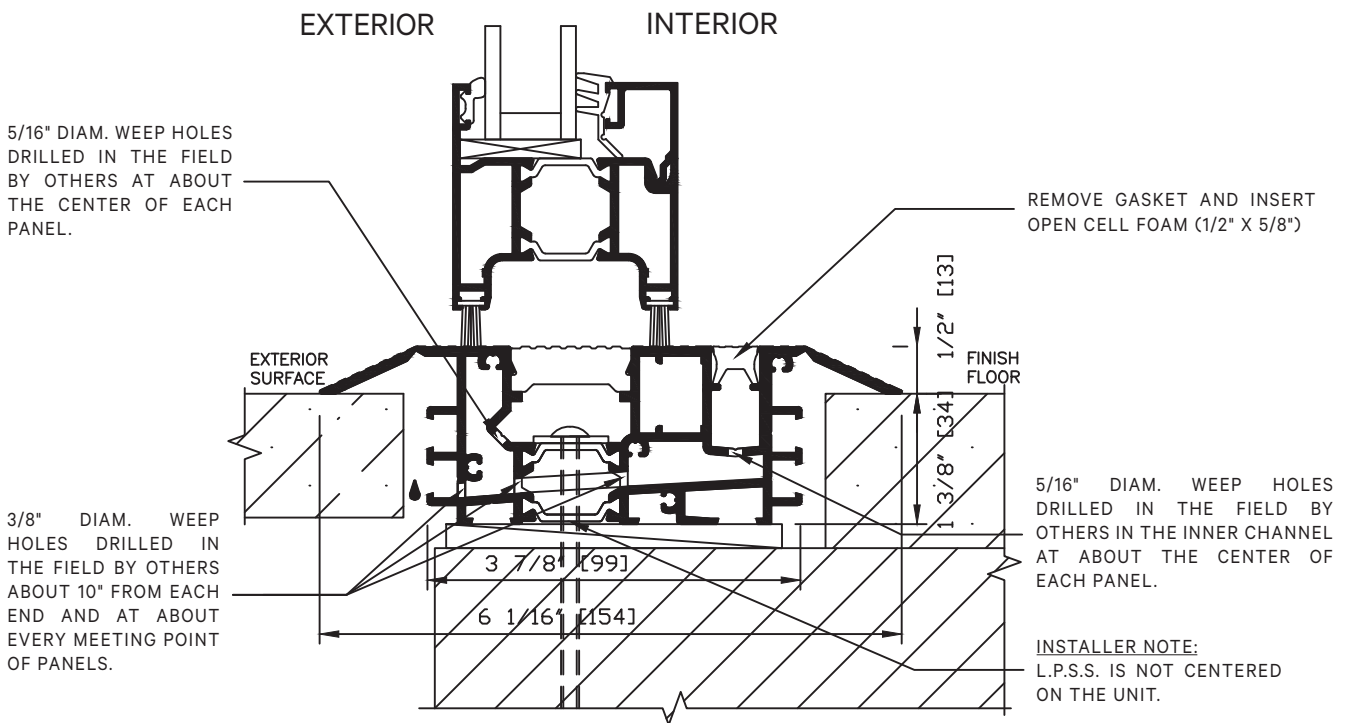

NOTE:
MAKE SURE THAT ANY FASTENER HOLES AND EACH END OF THE SILL ARE SEALED PROPERLY. FROM THE FRONT FACE OF THE SILL, DRILL HOLES ALL THE WAY TO THE BACK AS SHOWN AT A SLIGHT ANGLE UPWARD TO NOT PUNCTURE THE SILL BOTTOM EXTRUSION.

BESIDES PROPER WATERPROOFING OF THE JOB SPECIFIC SURROUNDING CONDITIONS, ESPECIALLY PROPER FLASHING UNDER THE SILL AS A WATER BARRIER, DETAILS OF THE MANAGEMENT OF WATER EXITING THE WEEP HOLES MUST BE DESIGNED AND PROPERLY INSTALLED BY OTHERS.