



# Owner's Manual

## NanaWall HSW66

### Wood Framed Single Track Sliding System

This Owner's Manual contains instructions on the installation, operation, maintenance and warranty of the NanaWall HSW66 Wood Framed Single Track Sliding System. This manual is to be used by the installer for installation and is to be kept by the Owner for reference. Replacement parts can be ordered directly through NanaWall Systems.

If a screen unit is ordered, separate instructions are provided in the package with the screen unit. See also screen installation considerations on page 6.

# Installation Instructions

The installation of the HSW66 System requires a working knowledge and experience in the use of tools, equipment and methods necessary for the installation of doors, windows, storefronts and/or partitions. This practice assumes a familiarity with preparing a proper and structurally sound opening, proper structural support for stacking bays, proper anchorage, waterproofing, caulking and sealing and assumes an understanding of the fundamentals of building construction that affect the installation of large horizontal single track sliding systems. A crew of at least 2 persons is needed. These systems can be heavy. Use safe lifting techniques to avoid injury and product damage.

**Highly recommended is using a NanaWall-trained independent installer, if available, or, at least, an installer who has some experience in installing NanaWall systems.**

For all projects in Florida and/or higher windload areas (DP of greater than +/-20 psf), the stricter of these instructions and FL product approval #FL14820 Evaluation Report and Installation Drawings should be followed.

**IMPORTANT: READ COMPLETE INSTRUCTIONS BEFORE BEGINNING INSTALLATION. INSTALL AS RECOMMENDED; OTHERWISE, THE UNIT MAY NOT FUNCTION PROPERLY AND ANY WARRANTY, WRITTEN OR IMPLIED, WILL BE VOID.**

## CAUTION:

As regulations governing the use of glazed windows, doors, storefronts and/or partitions vary widely, it is the responsibility of the building owner, architect, contractor or installer to insure that products selected conform to all applicable codes and regulations, including federal, state and local. NanaWall Systems, Inc. can assume no

obligation or responsibility whatsoever for failure of the building owner, architect, contractor or installer to comply with all applicable laws and ordinances and safety and building codes.

The HSW66 system is shipped with all necessary components. However, **not included** are screws, bolts, shims, etc. to anchor the unit to the opening. The frame is shipped knocked down and needs to be assembled. Panels are pre-assembled with glass (most cases), ready to be attached to the installed frame. In most cases, all rollers, hinges, weather stripping, multiple locking and flat handles are pre- attached to the panels and frame components.

## DESCRIPTION OF SUPPLIED PARTS

First look for an envelope in the shipment, which contains drawings of the elevation and the layout of the unit. This information together with the product drawings provided by NanaWall at the time of order will be needed for a successful installation. As there is **no "standard" configuration** for HSW66 units, see Diagram 1 and 2 for an example to illustrate the installation process. Diagram 1 show the elevation and layout of an Example with a 4 Panel Unit. Some items may not be applicable for your unit. Inspect the elevation drawing, indicating size, configuration and labeling of the unit ordered.

Check all parts carefully before assembly. Depending on the unit ordered, some of these parts may already be pre-installed on the panels. Check that the sizes of the frame components and panels match with what was ordered.

The elevation drawing shows the sequence and number of panels, which depends on the unit ordered. **The drawing is always viewed from the inside.** The panels are pre-assembled with two upper carriers for each sliding panel and with flat handles for the standard locking mechanism. **The sequence of labeling of panels starts from the left looking from inside with the left most panel labeled Panel 1.**

DIAGRAM 1: EXAMPLE WITH A 4 PANEL UNIT

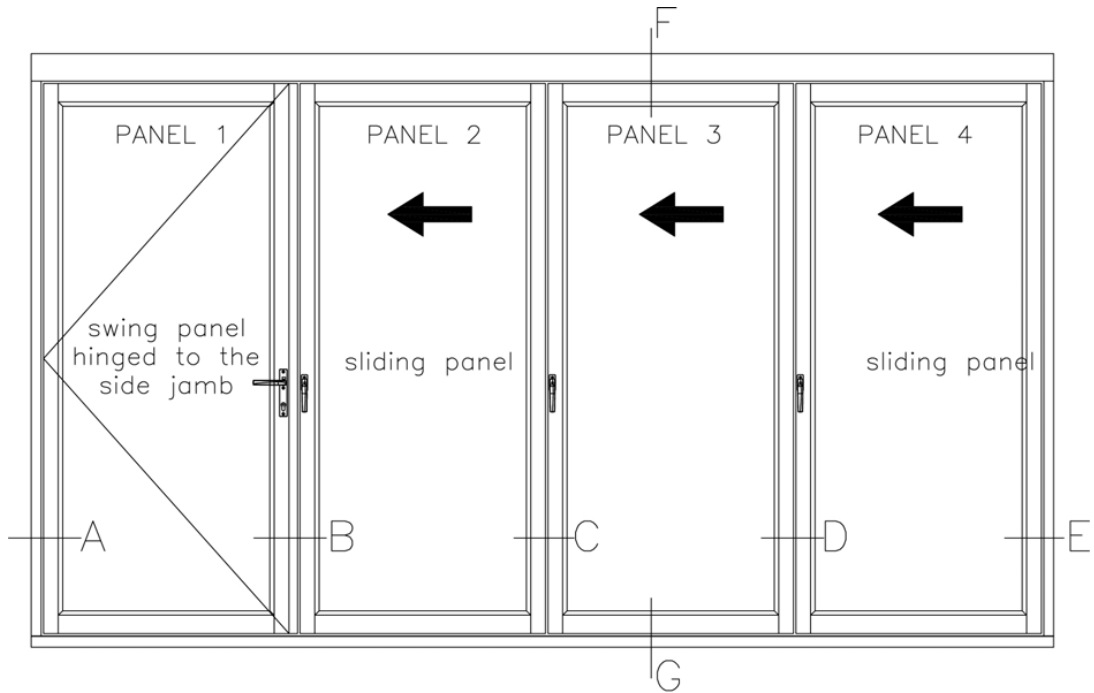

ALL PANELS IN CLOSED POSITION

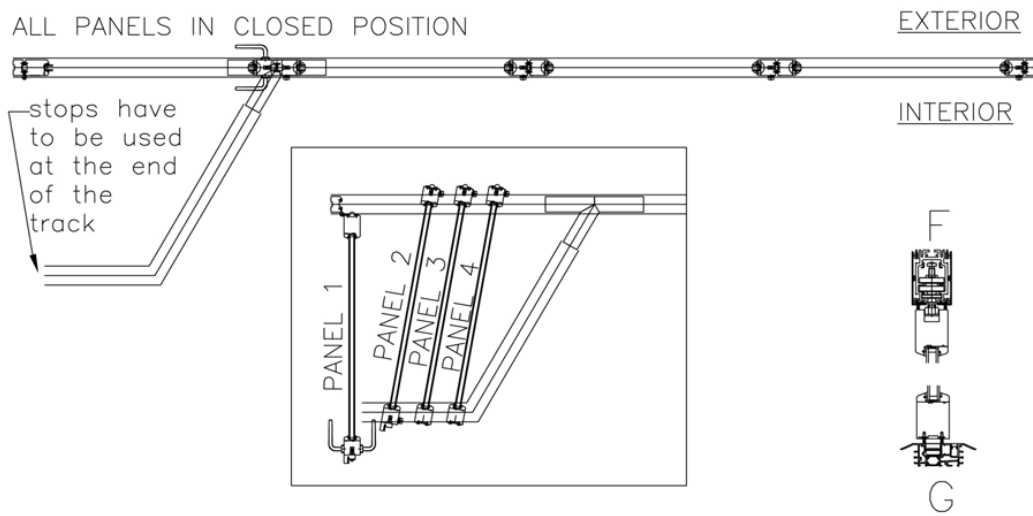

SEQUENCE OF PROFILES

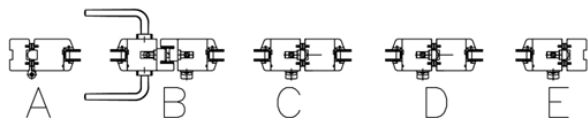

Other components include:

- For swing panels, mortise locksets and/or deadbolts as per order are pre-installed.
- Lever handles, other handles or other entry hardware as ordered may not be pre-attached to the panels and will be in the hardware box or shipped separately.
- For swing panels, hinge pins with washers – one for each set of hinges. Please note that the hinge pins may vary in size depending on the connection.
- Left side jamb, labeled L, and right side jamb, labeled R (may not be needed for certain configurations).
- The layout drawing of your unit shows the upper track components consisting of the head track in the opening, the stacking route(s) and the stacking bay(s), how they are labeled and how they have to be connected. The same information for the sill segments is provided, if a unit with a sill was chosen. The joints for the segments are indicated and necessary connectors and set screws for connecting different upper track and sill pieces are pre-attached to one of the two segments to be connected.
- The location of the access slots in the head track to insert the rollers on panels is indicated on the layout drawing. There is also a label on the upper track on the exact location.
- The ends of the stacking bay are covered with plates and have stoppers installed. The stoppers have to remain in place otherwise the panels may slide off the upper track.
- For units with a sill, receivers for the locking mechanisms on the panels are inserted in the sill. If the sill is straight, then all of them could be found at one end. If the sill is segmented, then the necessary number of locking receivers can be found at one end of each segment. A roll of sill gasket is provided with

the correct overall length that is to be cut on site to be inserted in the channel between locking receivers after the locking receivers are placed in the proper position to receive the locking mechanisms.

- For units with NO SILL, adjustable floor sockets are supplied with additional installation information.

## HANDLING OF COMPONENTS

1. Upon receipt, inspect the shipment to ensure it is in good condition.
2. Make sure that all components and hardware, which might be shipped separately does not get lost.
3. Store in a clean and dry location and protect against defacement or damage, especially to the edges of panels.
4. Wood components should not be subject to extreme or rapid changes in heat or humidity, such as forced heating to dry out a building.
5. **All wood surfaces including all edges (top, bottom and sides) should be completely sealed and finished promptly**

## PREPARATION OF THE OPENING AND SUPPORT STRUCTURE ABOVE

Make rough opening about 3/4" wider than the outside unit frame width. The height of the rough opening relative to the unit frame height depends on the installation detail chosen after accounting for the recessing of the sill and the space above the head jamb needed for an adjustable anchorage mechanism or appropriate shim space. Shim space should not be more than 3/4" for projects with design pressures of less than 25 psf and not be more than 3/8" for project with design pressures of more than 25 psf. See Diagram 3 for Suggested Typical Installation Details. It is important

that the opening be the correct size.

Product performance, including air infiltration, water penetration, structural loading and forced entry and operation, depends on having the gap between the bottom of the panel and the top of the sill (or on a unit with no sill, but floor sockets, then the top of the finish floor) be 10 mm (about 3/8”).

Note that the outside frame height is measured from the bottom of the sill and not from the finish floor. If a unit with no sill is provided, the frame height is measured from the top of the finish floor.

The track length and layout have been supplied based on the configuration and sizes chosen and approved. Please refer to the layout drawing of your particular HSW66 project for the correct location of the support structure for the support of the head track at the opening, stacking route and stacking bay. It is important that the system is properly supported at the top and at the proper locations.

**IMPORTANT:** Any application should take into consideration the following:

1. As the HSW system is a top-hung system, it is essential that a proper substrate with the proper size and thickness be used as the support structure not only as support for the head track in the opening but support of the head track at all locations including the stacking bay and stacking route.
2. The structural integrity of the support structure is critical for proper operation. **Vertical deflection of the header under full live and dead loads should be the lesser of  $L/720$ th of the span and 1/4”.** Structural support for lateral loads (both windload and when the panels are stacked open) must also be provided.

3. A qualified engineer or architect should be used to determine the proper construction details and super structure to be used in your particular application.
4. **THE ROUGH OPENING SHOULD BE LEVEL, PLUMB AND SQUARE AT ALL POINTS. THERE SHOULD BE NO UNEVENNESS OR BOWING. MAKE SURE THAT THE HEADER IS NOT TILTED OR TWISTED. THERE SHOULD BE NO BUMPS ON THE FLOOR. THE SIDES SHOULD BE IN THE SAME VERTICAL PLANE AND NOT OFFSET OF EACH OTHER. A TRANSIT/ LASER AND OTHER SIMILAR PRECISE MEASURING EQUIPMENT SHOULD BE USED. YOU NEED TO ADJUST THE FLOOR AT THE OPENING TO MAKE IT ABSOLUTELY LEVEL.**
5. With the low profile saddle sill and the flush sill, if concrete is to be poured after the installation of the unit, the sill has to be securely attached to the construction. If the sill is to be cast in concrete, then an expansion gap with appropriate material has to be created next to the sill.
6. **IMPORTANT:** If planning to cut or drill into post tensioned concrete, a structural engineer should be consulted and his directions followed.
7. With a low profile saddle sill, some resistance to water infiltration may be achieved by installing drain connections to the outside. Ask NanaWall for details.

**If any anchorage or drain connection holes are made through these drain channels, make sure that they are properly sealed to prevent any water leakage. The open ends of these drain channels at each end of the sill should also be properly sealed including all areas where the sill parts are joined together.** Alternative anchoring systems for the sill are using L brackets attached to both sides of the sill.

8. For a unit **with floor sockets** and no sill, the finish floor will need to be perfectly level with no unevenness. Floor sockets will need to be installed at precise locations after all panels are installed and final adjustments are made. See under D: LOCKING RECEIVER OR SOCKET INSTALLATION. The following points should be considered for the installation of floor sockets in concrete slabs and wood. The substrate should be a minimum of 4" thick. The embedment of the sockets into the concrete or wood should be a minimum of 1". The clear edge distance in concrete or wood should be a minimum of 1", when the sockets embedment is 2". If the socket embedment is 1", the clear edge distance should be a minimum of 2".
9. Installations into heavy gage all metal studs must have wood backing.
10. For better performance and protection, any exterior single track sliding system should be installed under an overhang or with other similar protection.
11. **For better performance it is strongly recommended that all dead loads such as upper levels, roof, etc. be constructed and reasonable time for it has been allowed to settle before a unit is installed.**

Properly flash and waterproof around the perimeter of the opening, especially at the sill. Make sure you seek proper professional advice for the appropriate construction needed for your particular application. Do not install unit in structures that do not allow for proper management/drainage of moisture. Peel and stick or ice shield should be used on all bottom seals.

To avoid future problems, do not install your unit until the rough opening and the support structure have been correctly prepared.

### **INSTALLATION CONSIDERATIONS IF THE SCREEN CLASSIC/ONE IS TO BE INSTALLED FOR THE NANAWALL UNIT**

1. There must be an adequate frame by others at the top and sides to which the Screen Classic/ONE is to be attached. Although there is not much weight or load from the Screen Classic/ONE, the frame must not sag or deflect.
2. The bottom rail would need to be attached to the top of the finish floor. The installation of the Screen Classic/ONE may need to be delayed until the finish floor is installed.
3. If the finish floor is higher than the bottom of the NanaWall sill, the height of the Screen Classic/ONE will need to be shorter than the height of the NanaWall unit to allow for the difference in height between the bottom of the NanaWall unit and the finish floor.
4. To allow for stacking of the Screen Classic/ONE beyond the NanaWall opening, the width of the Screen Classic/ONE will need to be wider.
5. If the width of the Screen Classic/ONE is the same as the NanaWall unit and if the header and wall are wide enough, they can be used as the frame for the Screen Classic/ONE. If not, a separate frame will be needed. It could be attached to the header and wall.
6. Please note that if a separate frame for the Screen Classic/ONE is made, please make sure that there are no gaps between the frame and wall that will allow any bugs to pass through.
7. **Sufficient distance (a minimum of 2 ½") must be allowed between the Screen Classic/ONE and NanaWall units to allow clearance for any handles on**

the units. The Screen Classic/ONE must also clear the sill of the NanaWall unit.

8. Please see the separate Installation Manual of the Screen Classic/ONE.

## WOOD FINISHING AND MAINTENANCE RECOMMENDATIONS

NanaWall wood framed systems are shipped with a factory applied layer of a waterborn translucent coat of sand sealer or primer, which is an acrylic-copolymer-dispersion from Sikkens ([www.nam.sikkens.com](http://www.nam.sikkens.com)). NanaWall aluminum clad wood framed systems are shipped with a similar additional coat. These factory applied coatings are not a sufficient and adequate protection from the elements and at least two coats of a final finish need to be applied in the field.

**IMPORTANT:** Immediately upon receipt of the unit and prior to installation and exterior exposure to weather elements, all wood surfaces including all edges (top, bottom and sides) should be completely sealed and must be protected with a good quality finish. Before installation, keep the units in a dry and clean location, store and stack them properly to avoid twisting or warping of the panels and frame components.

To complete the wood surface treatment use compatible finish material. If you think the product that you are intending to use is not compatible, then completely remove all pre-applied coats by chemical stripping (please follow the direction of the product) or by sanding off. Do not use power wash or excessive water. Then apply a good quality sealer or primer and continue applying the necessary coats as recommended by the product you have chosen.

### CAUTION:

Not all available paints and stains, nor the customer's specific application requirements can be evaluated. Your local paint professional should know of suitable finish systems that give satisfactory results in your region. It is highly recommended that top quality finishes be selected, and the directions of the products be followed explicitly.

In general, the surface must be prepared by cleaning off dust and any debris. With 180-220 grit sandpaper, sand lightly and thoroughly all surfaces to be painted. Do not use steel wool or silicon carbide type sandpapers. Then clean the surfaces before applying paint, etc. For best performance, a minimum of two topcoats should be applied.

**Always make sure that you apply the coatings on a hidden area before finishing the whole unit to make sure you are satisfied with the results.**

Ensure not to apply the coating material on to hardware, gaskets, glass, sealant or aluminum surfaces to maintain proper product performance.

All damages or scratches during installation on the surface coating should be immediately touched up.

### WOOD SIMULATED DIVIDED LITES (SDL)

It is recommended that after completing the surface treatment of the SDL and after allowing for adequate drying time, to seal the gaps between the SDL and glass with a durable weather resistant caulking material, which is compatible with the surface treatment material.

### MAINTENANCE OF WOOD UNITS

As a general guideline it is recommended that every 1/2 year or earlier, to inspect visually the surface and if necessary re-finish in the same manner as per instructions above. The timeframe may vary on weathering, exposure conditions and altitude. Whenever damage is visual, it should be repaired immediately.

**PREPARATION OF THE SUPPORT STRUCTURE ABOVE**

Instructions for anchoring the head track with the adjustable anchorage assembly as shown in Details 1 or 2 in Diagram 3.

1. Anchorage of the upper track should be made with Series 300 stainless steel threaded rods with diameter of 3/8" with nuts and washers to match that are not smaller than shown in Diagram 2. In the groove that is at the top of the upper track, a typical standard nut with dimensions that fits in the groove (not to exceed 11/16" (17.5 mm) in width and 7/16" (11 mm) in height) should be used. Min. yield strength of the rods must be 50 ksi and min. ultimate tensile strength must be 100 ksi. As shown in Diagram 2, the maximum distance between the top of the upper track and the header should not be more than 1-9/16".

Please see Diagram 5 for proper spacing of the threaded rods in the opening. The proper spacing depends on the the design wind load pressures and the panel height.

The spacing of the threaded rods in the stacking bay should be every 4" and in the stacking route every about 18". Please see Diagram 4.

**DIAGRAM 2: ADJUSTABLE ROD ANCHORAGE SYSTEM DETAIL**

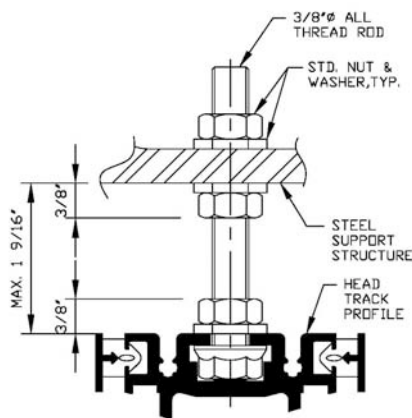

2. Please note that the holes in the support structure have to be drilled before the frame is set in the opening. If steel is to be used, it is recommended that all anchorage holes in the steel support structure be prepared by the steel supplier before installation of the steel structure. Please make sure that the structural integrity of the steel is still intact.
3. Determine the location of all anchorage points on the support structure. Make sure the points chosen correspond to where the center of the upper track is to be placed in relation to the support structure as shown in any detail drawings provided by the architect or owner.
4. As the nuts to be placed in the upper track groove can only be placed along the length of the profile and since some tolerance in the drilling of the holes in the support structure must be allowed, it is recommended that oblong holes be made as shown in Diagram 4.

For anchoring the head track with screws through the head track as shown in Detail 3 in Diagram 3, please see Step A4. Do not install your unit until the support structure has been correctly prepared.

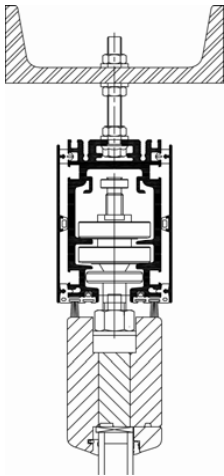

**DIAGRAM 3: HSW66 SUGGESTED TYPICAL INSTALLATION DETAILS**

Suggested Typical Installation drawings shown are very general and may not be suitable for any particular installation. Product placement, fasteners, flashing, waterproofing, sealant, trim and other details for specific surrounding conditions must be properly designed and provided by others.

Drawings not to scale.  
Details shown are subject to change without notice.

**Detail 1:** HEAD JAMB with a adjustable rod anchorage system.



**Detail 2:** HEAD JAMB with adjustable rod anchorage system and steel "C" channel.

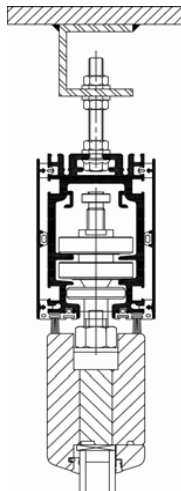

**Detail 3:** HEAD JAMB with hard plastic shims between head jamb and header. (This detail is not recommended for larger openings or larger panels in which the adjustable rods make adjustment easier.)

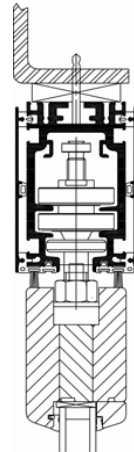

**Detail 4:** FLUSH SILL (no rating against wind driven rain)

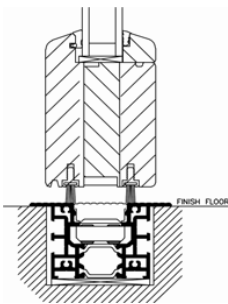

**Detail 5:** LOW PROFILE SADDLE SILL (for some resistance against wind driven rain, drain connection by others necessary)\*

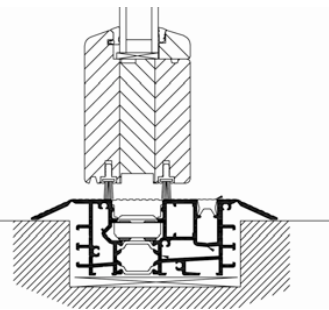

**Detail 6:** ADJUSTABLE FLOOR SOCKET (no rating against wind driven rain)

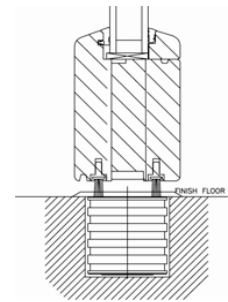

**Detail 7:** SIDE JAMB MEETING SLIDING PANEL

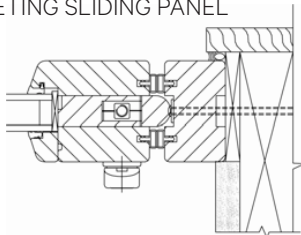

**Detail 8:** PANEL HINGED AT SIDE JAMB

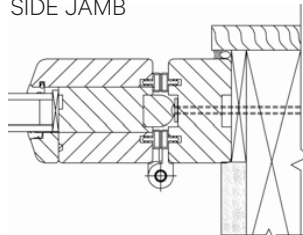

\*Generally as follows:

1. Remove the gasket covering the inner channel
2. Provide necessary weep holes at the bottom of channels and on the outside face of the sill.
3. Make necessary drain connections
4. Ask NanaWall for a detailed drawing

**DIAGRAM 4: VIEW FROM THE TOP OF A TYPICAL STEEL SUPPORT STRUCTURE**

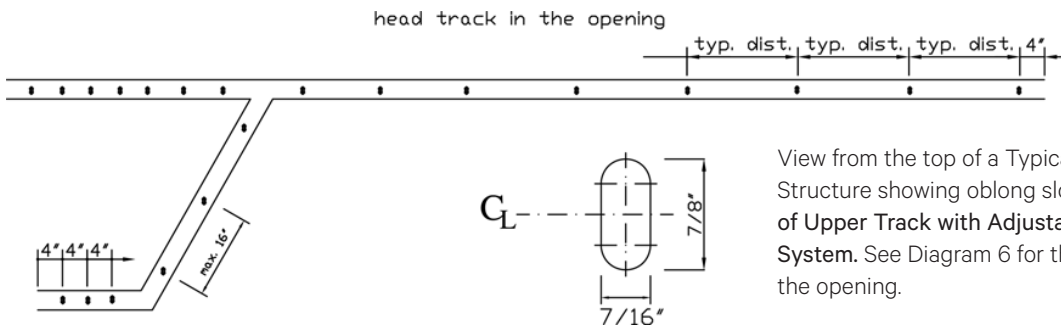

View from the top of a Typical Steel Support Structure showing oblong slots for Anchorage of Upper Track with Adjustable Rod Anchorage System. See Diagram 6 for the correct spacing in the opening.

**A. FRAME ASSEMBLY AND INSTALLATION**

Since there can be an infinite number of variations of stacking options and configurations, it is not possible to have step by step specific instructions that will apply to all units installed. Below are general instructions that may not exactly apply to your particular unit. Please refer to the architectural drawings, product drawings or layout diagrams for your specific project.

**!** The key to having a properly installed and operating HSW66 system is to install a perfectly level upper track at the correct height from the finish floor and having the upper track precisely aligned to the lower track.

**Step A1**

Look for the labels on the different upper track segments and set them on the floor as per the layout drawing/ cutting list of the head track profile SL5-60-20.

**Step A2**

For the upper track segments to be joined together, if the aluminum cover profile SL5-60-21 with or without a wood fascia was provided, remove them from both sides. Make sure they are marked, so they roller access slot can be re-attached to the correct upper track later.

Find the roller access slots on the upper track through which the carriers on each panel will be inserted. A label

shows the exact location. It should be a cut in the track about 2-3" wide. To open the slot, first pry open the upper track cover, then loosen the set screws on the connector piece and move it to one side. Depending on the unit ordered, roller access could instead be from the ends of the head track in the stacking bay.

**ILL. 1: CONNECTION OF HEAD TRACK PROFILE SL5-60-20**

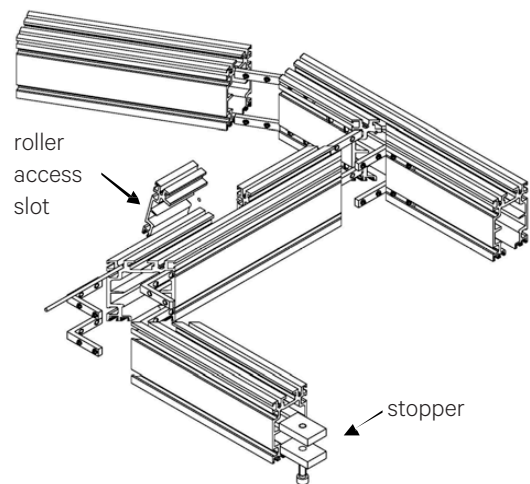

**DIAGRAM 6:  
SPACING FOR STAINLESS STEEL THREADED  
RODS ADJUSTABLE ROD ANCHORAGE SYSTEM  
AT UPPER TRACK**

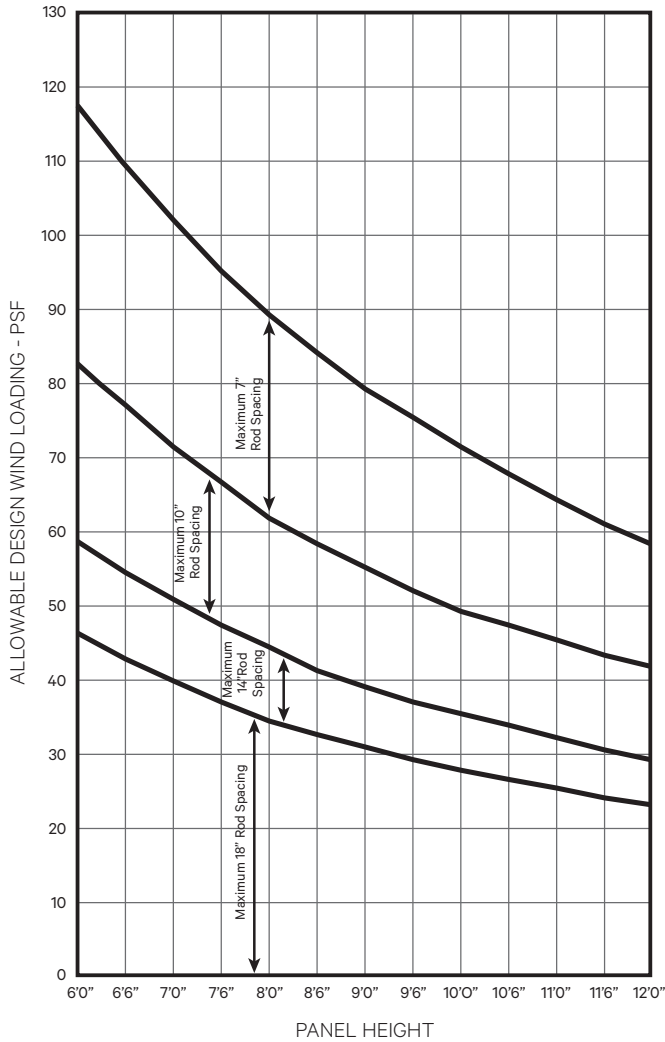

**DIAGRAM 7:  
SPACING FOR INSTALLATION FASTENERS  
DIRECTLY INTO MASONRY BLOCKS AND  
CONCRETE**

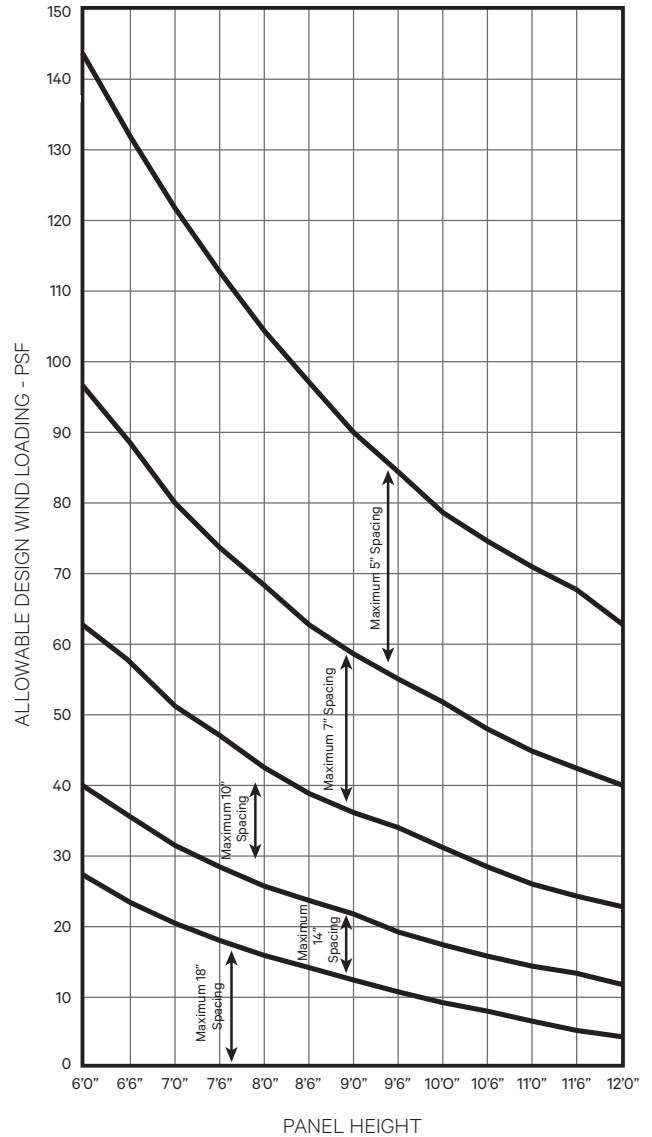

**NOTES**

1. Treated rod material to be Series 300 stainless steel with FY = 50 ksi minimum and Fu = 100 ksi minimum.
2. Nuts and washers to be stainless steel, compatible with rod material.
3. Rod diameter to be 3/8".
4. Rod exposed length between the top of the head jamb and the header to be a maximum of 1 9/16".

**DIAGRAM 8:  
SPACING FOR INSTALLATION FASTENERS  
DIRECTLY INTO WOOD**

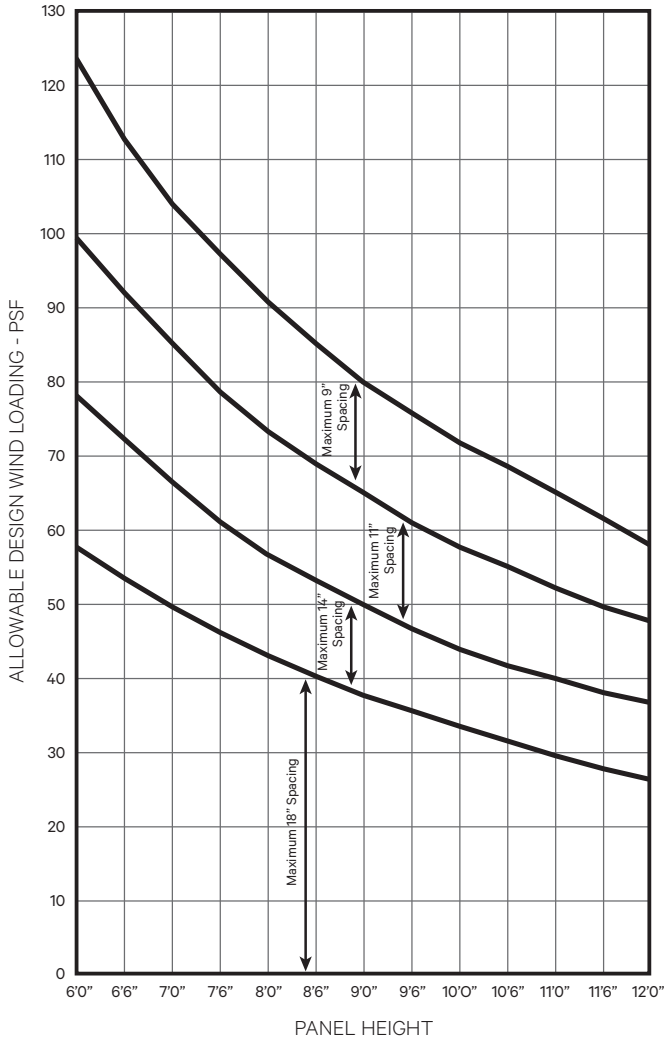

**DIAGRAM 9:  
SPACING FOR INSTALLATION FASTENERS  
DIRECTLY INTO STEEL (14 GAGE MINIMUM)**

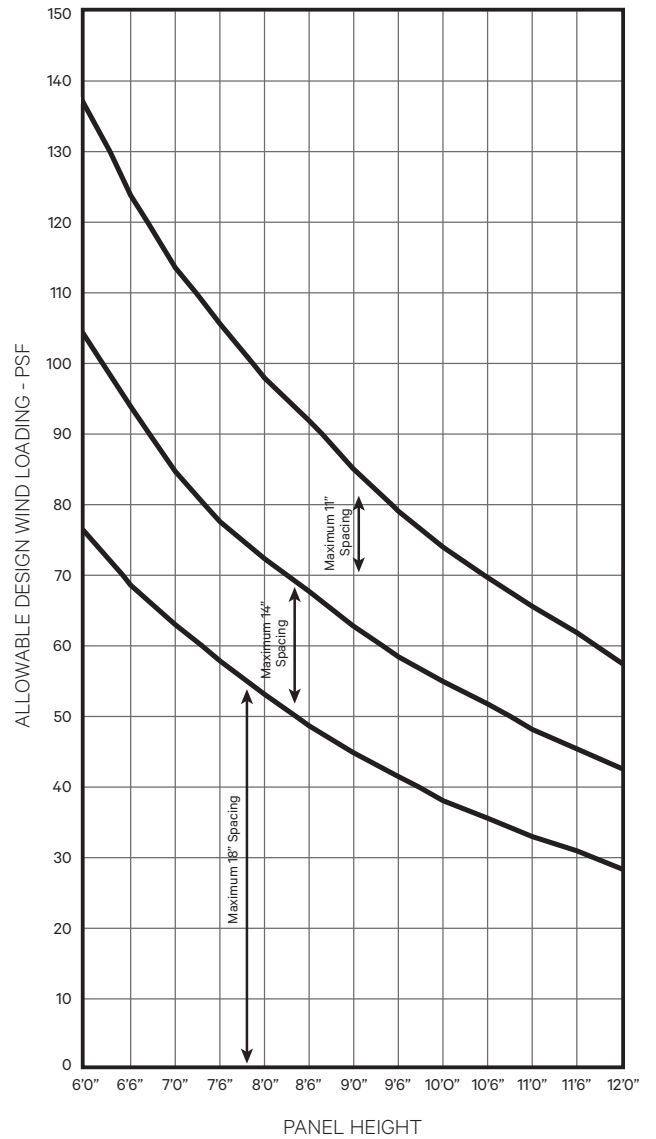

**Step A3**

Attach as many of the upper track pieces together that could be supported and installed easily as one piece. Use the connectors and set screws provided. See Illustration 1. Make sure that the correct angles between segments are maintained.

**Step A4**

For anchoring the head track with screws through the head track as shown in Detail 3 in Diagram 3, pre-drill anchorage holes in the head track. Please see Diagrams 6, 7 and 8 for correct fastener spacing in the support structure within the opening. The spacing depends on the substrate material, the project design wind load pressures, and the panel height.

The spacing of anchorage devices in the stacking bay should be every 4" and in the stacking route every about 18". Please see Diagram 4.

Use appropriate screws or other equivalent anchorage devices depending on the adjacent substrate material and construction. Make sure they are corrosion resistant and that the screw head is small enough to fit inside the slot in the middle of the head track; otherwise, it will interfere with the carriers. Anchorage devices should penetrate or hold sufficiently to the opening to withstand necessary structural loading. Generally, for wood frame, use #14 (1/4" diameter) wood screws with 2-1/2" minimum embedment, for concrete with a minimum compressive strength of 2,000 psi use 1/4" diameter ITW Tapcons (concrete screws) with 1-1/4" min. embedment and min. edge distance of 1 1/2", for masonry use 1/4" diameter ITW Tapcons (masonry screws) with 1-1/4" embedment and min. edge distance of 2", for light gage steel substrates with a minimum of 14 gage (0.075" thick) use 1/4" diameter type 300 stainless steel self drilling screws and for structural steel substrates thicker than 1/4", use 1/4" diameter SAE Grade 2 bolts with holes that are predrilled. Another option in structural steel substrates is to use

type 300 stainless steel self drilling screws with small pilot holes that are predrilled.

**Step A5**

For all anchorage options, set the assembled part of the upper track into the rough opening at the proper position relative to the super structure and the finish floor.

**Step A6**

Support the upper track temporarily in a safe manner, for example, construction posts or with straps/ropes tied around the header.

**Step A7**

If the adjustable rod anchorage system is used, then loosely attach the threaded rods with all necessary washers and nuts to the oblong holes in the support structure. Anchor the upper track to the support structure by screwing the threaded rods into the nuts, which are in the groove on top of the head track. Lock them safely with nuts and washers on the top of the head track profile.

For anchorage with screws through the upper track, place hard plastic horseshoe shims tightly at every fixing point between the upper track and the header. Anchor the head track with appropriate screws through the pre-drilled holes.

**Step A8**

Assemble and install other segments of the upper track in a similar manner.

Make certain that the angles between different upper track components are exact.

If the stacking bay has parallel legs, make sure that the legs are exactly parallel. The aluminum plate provided to connect the ends help to insure this.

**IMPORTANT:** Adjust each anchorage point as needed to make the upper track absolutely level and plumb. Use a transit/laser and other similar precise measuring equipment to make these determinations.

**Step A9**

If there is a sill provided for the unit, the first step of assembling the sill will be to look for the labels on the different sill segments and set them on the floor as per the layout drawing.

**Step A10**

Starting at about 4" from each edge, drill holes for anchorage devices to connect the sill to the opening at the same spacing that is used for the head track as described in Step A4 above. Use appropriate screws and anchorage devices as described in Step A4 above.

**Step A11**

Attach as many of the sill pieces together that could be supported and installed easily as one piece. Use the connectors and set screws provided. Make sure that the correct angles between segments are maintained.

**Step A12**

Set sill in place; make sure it is in the correct position and is plumb and aligned with the upper track. Make sure that the correct height between the sill and the head track is maintained.

Shim the sill as needed with hard plastic horseshoe shims located at the pre-drilled holes to make sure it is absolutely level. If there are bumps or unevenness in the floor, they would need to be evened out so that the height for the unit remains the same. Use hard plastic horseshoe shims only.

Anchor the sill through the pre-drilled holes and shims. Penetration should be as described in Step A4. Make sure that all holes drilled through the sill are properly sealed with for example silicone underneath and around the screws.

**If a unit is supplied with NO SILL, do not make any socket holes in the floor yet!**

**Step A13**

Installing the **side jambs**; pre-drill holes for the anchorage devices to connect the side jamb to the opening at the same spacing that is used for the head track as described in **Step A4** above. Use appropriate screws and anchorage devices as described in **Step A4** above.

**Step A14**

Set the side jamb in place and align with the sill. See Illustration 2. Support them temporarily with clamps.

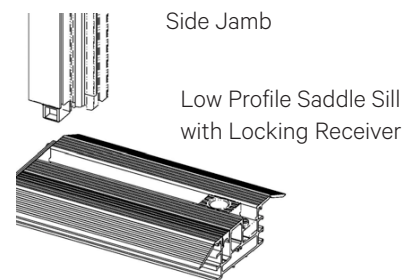
**ILL. 2:****CONNECTION OF SIDE JAMB AND SILL****Step A15**

Place hard plastic horseshoe type shims tightly at every anchorage point between the side jamb and the wall to make the side jamb absolutely square and straight. Anchor the side jambs through the pre-drilled holes and shims.

**IMPORTANT:** Make sure no shims are forced to ensure that the frame sections are not bowed. Check frame constantly to be certain that it is level, plumb and square. A transit/laser and other similar precise measuring equipment should be used to make these determinations.

Make sure that all surfaces of the upper and lower tracks are clean and free of any debris, especially, cuttings from drilled holes.

## B. PANEL INSTALLATION

As there can be many possible configurations, panel installation will vary with each unit. Below are general guidelines. Look for the glass stops to determine the interior side of a panel.

### Step B1

Looking at the elevation drawing, if there is a swing panel attached to the side jamb, align the hinge components and install the panel with the hinge pins.

### Step B2

Check all the carriers on all the panels. Make sure all the locking nuts are securely tight. Do not make any adjustments on the carriers.

### Step B3

Hang panels not attached to a side jamb by inserting the carriers on each panel into the carrier access slots in the upper track in the proper sequence.

### Step B4

Install additional panels in the same manner.

### Step B5

For SwingSlide units, after installing all the sliding panels, engage the locking points on the panel adjacent to the swing panel. The locking operator is located on the edge of the panel. Align the hinge components of this panel and the swing panel and install the hinge pins.

### Step B6

For SwingSlide units, attach the panel catch to the swing panel stile with the handle and the catch counter-part to the opposite stile of the adjacent panel. Follow the specific instructions that are on the sheet in the panel catch kit.

**IMPORTANT:** The purpose of this is that the swing panel should always be opened and engaged into the panel catch before the panels are to be stacked open.

**CAUTION!** For SwingSlide units, the swing panel should not disengage from the panel catch engaging it with the adjacent panel unless all sliding panels are properly closed and all locking points engaged, especially the locking through the concealed operator at the side of the panel adjacent to the swing panel. Otherwise, the swing panel will not be stable and can be damaged. When sliding the panels into the stacking bay, the first step should be opening the swing panel and engaging it into the panel catch with the adjacent panel.



## C. GAPS AND ADJUSTMENT

After inserting and sliding all panels in the closed position, check if all panels are vertically straight. Between panels there should be an even gap of 10 mm (about 3/8") from top to bottom. Any problems may be due to the side jambs not being plumb or the head track not being absolutely level. A difference of 1/16" or less in the level of the head track between the two corners of a panel can cause a 1/4" shift of the panel from the vertical position – enough for a panel not to close properly.

The horizontal spacing between the upper track and the top of a panel and between the bottom of a panel and sill or finish floor (if there is no sill) should be 10 mm (about 3/8").

**If the gaps are not correct, then adjust the side jambs or upper track. The upper track has to be perfectly level. UNDER NO CIRCUMSTANCES SHOULD THE CARRIERS/ROLLERS BE ADJUSTED.**

## D. LOCKING RECEIVER OR SOCKET INSTALLATION

For units **with a sill**, move all the locking receivers so they are in the correct position below the locking rods. Tighten the screws. Close and lock all the panels. Move and adjust the locations of the locking receivers as needed.

For units with no sill, holes in the floor for the sockets have to be made at exact precise spots. There is no second chance if the hole location is off. Once a panel is in the correct position, turn the handle cautiously and mark the correct locking spot on the floor before drilling. Follow the separate installation instructions that are provided with the floor sockets.

## E. FINAL STEPS

### Step E1

Close and lock all panels into position.

### Step E2

Check all vertical and horizontal joints and adjust them as described under section C: GAPS AND ADJUSTMENT. Move and adjust the locking receiver or floor sockets as needed.

### Step E3

Attach handles and other hardware that have not been pre-attached. Attach the profile cylinder (if any) to the locking gear by inserting it into the lock hole and attaching the set screw through the screw hole on the gear located at the edge of the panel. Cut the set screw, if needed, so it is not longer than 1-1/2".

### Step E4

Check that the system operates and functions properly. Open and close all the swing panels. For SwingSlide units, before sliding the panels open, make sure that the swing panels are opened and engaged into the panel catches. See **CAUTION** in Section C above.

The panels should move easily in the opening and should stack smoothly in the stacking bay. Check to see if all upper track components are properly installed. Check if all angles are correct. Each leg of the stacking bay track should be equidistant at all points. Spray the carriers as needed with the lubricant provided or use Teflon spray for smooth movement. When opening or closing, all shoot bolts should engage smoothly.

### Step E5

Re-attach the aluminum cover profiles on the upper track and wood fascia, if any.

### Step E6

For a unit with a sill, measure and cut to the proper lengths the gasket to be installed in the channel to cover the space between the locking receivers. For a SwingSlide unit, no gaskets should be placed where it would interfere with the pins at the bottom of some panels.

### Step E7

Correct any problems before finish trimming. While finishing trim and eventually dropping the ceiling pay attention to roller access locations. The head track should not be subject to any loads from suspended ceilings, etc.

### Step E8

Apply a thick bead of exterior grade sealant with a backer rod if needed on the joint between the sill and floor on both sides along the length of the sill. Do similar for the gaps between the head jamb and side jambs with the opening.

### Step E9

Finish any waterproofing, flashing, trim and sealant needed around the perimeter of the opening.

### Step E10

**IMPORTANT:** If any weep holes were installed in the sill by others, then make sure that they are not blocked.



**PROTECTION OF UNIT DURING  
CONSTRUCTION PHASE**

It is important that during the construction phase the unit be kept closed, covered and protected from damage. During this phase, a unit is often subject to the most extreme conditions from all types of construction operations that can permanently damage and destroy it. A unit can be damaged by cement splatter, tar, paint, weld splatter, falling objects, construction dust, sand blasting, etc. All temptations to use the large opening of an installed system for easy ingress and egress by tradesmen should be resisted.

# Operation And Maintenance Of NanaWall Products

## OPERATION OF A NANAWALL HSW - SINGLE TRACK SLIDING SYSTEM

For opening and closing the single track sliding system, please observe the special notes on the following pages in as far as they relate to your unit.



**When operating the system similar to any other door, please do not place your fingers between the panels/pivot points.**

Only properly trained personnel should operate the unit.  
No children should operate the unit.

Do not force the system if not operating properly. Please have it repaired as soon as possible by a qualified technician.

Secure panels when in the open position to prevent uncontrolled movement, especially in windy conditions, that might cause damage and injury.

Be sure not to operate the doors in high wind conditions.

It is highly recommended that if not used, the NanaWall unit be kept closed as much as possible. When closed, please engage all locking mechanisms fully. This will provide best security, weather resistance and resistance against warpage.

The correct sequence of opening and closing of panels is dependent on the configuration ordered. Panels must be opened and closed in the right order.

### Opening and Closing a Unit

1. For opening, if there are any incorporated swing panels (HSW60), convert the incorporated swing

panels to sliding panels as per instructions on the next page.

**IMPORTANT:** Correct procedure must be followed.

2. For Swing/Slide units (HSW66), open the swing panels first.

**IMPORTANT:** The swing panels must be opened all the way and **must** engage them into the panel catch on the adjacent panels.

3. If there are swing panels or wiggle panels attached to the side jamb (not incorporated swing panels), open these panels first.
4. Disengage the locking points on all the other panels.
5. Note that there is a carrier at each upper corner of a sliding panel. Look at the head track within the opening and note the switches that lead the head track from the main opening to the stacking bay. Guide the closest carrier of a panel through the appropriate switch and slide that panel into the stacking bay. **Attention: Move only one panel at a time.**
6. Similarly, slide all the remaining panels through the appropriate switch into the stacking bay.
7. In most cases, panels can be pushed in place with one hand pushing on a stile. Move evenly and keep panels as vertical as possible and push into the stacking bay. **Do not force. Avoid any pendulum movements, otherwise rollers may get damaged.**
8. If there is more than one stacking bay, please be sure the panels are stacked in the correct stacking bay.

9. For closing, proceed with the sliding of the panels in reverse order. To pull the panels from the stacking bay, you will need to pull the stiles of the panel. Move evenly and keep panels as vertical as possible. Avoid any pendulum movements.
10. Make sure each panel is placed in its proper position in the opening.
11. Engage all the locking points. Do not force any locking point.
12. Convert the incorporated swing panels (HSW60) from sliding panels to swing panels as per instructions below.
13. For SwingSlide units (HSW66), the swing panel should not be disengaged from the panel catch engaging it with the adjacent panel until all sliding panels are properly closed and all locking points engaged, especially the locking through the concealed operator at the side of the panel adjacent to the swing panel.

#### Conversion of an Incorporated Swing Panel from a Sliding Panel to a Swing Panel

1. When the unit is closed by moving all panels into the proper position in the opening, make sure all the locking points on every panel are properly engaged, especially the locking points on the incorporated swing panels. The flat handle to engage the lower locking point on the incorporated swing panel is found behind the circular pocket on the stile on the pivot side. Turn this handle 180 degrees.

**IMPORTANT:** The lower locking point on the pivot side of an incorporated swing panel has to be secured to the locking receiver in the sill or socket in the floor before the incorporated swing panel can function properly. Otherwise, it will not be stable and can fall and hurt somebody.

2. Using the crank handle found in the circular pocket on the stile on the pivot side, turn the slot in the Conversion Box located on the upper arm of the top rail so the upper arm engages to the head track and disengages from the top rail to release the swing panel. Stow the crank handle in the circular pocket.
3. The incorporated swing panel can now be used as a regular swing door with appropriate hardware.

#### Conversion of an Incorporated Swing Panel from a Swing Panel to a Sliding Panel

1. Close the swing panel.
2. Using the crank handle found in the circular pocket on the stile on the pivot side, turn the slot in the Conversion Box located on the upper arm of the top rail so the upper arm disengages from the head track and engages to the top rail. Stow the crank handle back into the circular pocket.
3. Turn the flat handle found behind the circular pocket on the stile on the pivot side to disengage the lower locking point.
4. The incorporate swing panel can now slide away just like all the other panels.

**OPERATING THE SL-MULTIPOINT LOCKING ON THE PRIMARY SWING PANEL(S)**

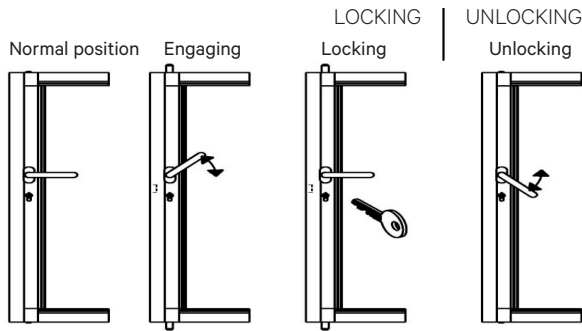

**Disengaging locking points**  
 (Note that this is not one motion operation. Key or thumbturn must be unlocked first.)



Be sure to check that the door is locked.  
 The door is locked, when the handle cannot be depressed.

**Engaging the locking points and locking**

- Turn handle up about 45° to engage the locking points. Then let it move back into its normal position.
- Only now can it be locked with a key on the outside or a thumb turn on the inside.

**Unlock and disengaging the locking points**

- Unlock the lock with key or thumb turn.
- By operating the door handle downwards, the locking points at the top and the bottom are disengaged.

## RECOMMENDED MAINTENANCE OF NANAWALL PRODUCTS

### Some General Considerations on all Projects:

1. It is important that the product is properly installed. A poorly installed unit will not function properly. This will cause more abnormal force or stress on the components and will lead to premature failure. When operating the unit, the panels should generally be able to be moved easily by one person (except when there are very large panels or when there are more than 6 panels folding to one side). All locking points should engage smoothly. There should be no rubbing on the floor and no binding. When the unit is closed, the reveal between panels and head jamb and between panels and sill should be consistent. There should be no daylight seen from the inside. Please have all problems corrected as soon as possible by a qualified technician.
2. From time to time, due to building movement or settlement, a unit may need to be adjusted by a qualified technician to compensate for any building change.
3. It is important that a unit is operated properly. Locking points should be gently opened and closed and not forced. Panels should be opened and closed in the proper manner and sequence. See the Operation section for proper operation.
4. Periodically check for worn or damaged components and replace as soon as possible. A unit with nonworking components will subject the other components to increased stress and lead to premature failure. A unit with worn or damaged components will compromise the performance level expected for air and water infiltration, structural loading and forced entry.
5. Periodically, inspect the sealant/caulking on the exterior perimeter of the unit. It is extremely important that the sealant/caulking remains intact and in good condition. Trim off any old, loose caulking and seal any gaps with a good quality caulk.
6. Check that all weep holes are clean and clear of any obstructions. Remove debris and other foreign bodies which have dropped into the tracks in the head jamb and sill immediately to prevent damaging the running carriages and guide trolleys (if any). Keep the sockets in the track or floor free from dirt and small stones. Clean all components as needed with soft cloths and acid-free household cleaners. Never use aggressive cleaning agents or abrasive cleaning wipes. Check gaskets for proper seating and condition. Remove dust and any deposits from these gaskets.
7. The finished aluminum or wood surface needs periodic cleaning and maintenance. Its appearance may be marred by harsh chemicals, abuse or neglect. Frequency of cleaning depends on exposure and needs. For aluminum surfaces, generally warm soapy water should be sufficient. Stubborn stains and deposits may be removed with mineral spirits. For wood surfaces, superficial surface dirt can be removed by washing with water and a soft-bristled, long-handled brush. Heavier accumulations can be removed with a mild solution of household detergent. For all surfaces, aggressive alkaline or acid cleaners should not be used. Excessive abrasive rubbing should be avoided. Sealants and weather stripping may be affected by strong organic solvents. Superficial damage to the aluminum surface must be touched up immediately with proper touch up paint.
8. If it is a wood product, periodically repaint or re-stain the wood as needed. Exposure to the environment will break down the finish and compromise its protective features if not refinished. See Finishing Recommendations in the Owner's Manual of the wood systems.

9. All hardware, hinges and handles should be periodically cleaned with a soft cloth and mild cleanser. Excessive abrasive rubbing should be avoided. Please note that oil rubbed brass is a finish that will develop its own unique patina over time.
10. About every six months, apply lubricant to all the hinges and Teflon spray to the top carriers and guiding pins (if any).

### **SOME SPECIFIC SUGGESTED MAINTENANCE FOR COASTAL SALT WATER AND OTHER EXTREME ENVIRONMENTS**

Please note that the environment within one mile of a sea coast can be extremely corrosive. Products installed in this environment will typically deteriorate sooner than products installed in a less severe environment.

1. Open and close completely a unit at least once a week and inspect all surfaces.
  - a. Salt and other corrosive or abrasive materials such as sand must not be allowed to build up on any surfaces, including all hardware and sill.
  - b. The sill and head jamb tracks should be free from all dirt and debris.
  - c. There should be no standing water in the track in the sill.
  - d. All hardware should be intact and operating properly.
2. All surfaces must be cleaned with a mild detergent soap and fresh water at least every month and more frequently if necessary.
  - a. After washing, the surface should be rinsed thoroughly with clean water and allowed to dry.
  - b. For cleaning, do not use abrasive household

cleaners or materials like steel wool or hard brushes that can wear and harm finishes.

- c. Any glass cleaner used should not be allowed to run down on any other surface.
3. Any breaches in the paint coating, such as scratches, chips or areas of abrasion, must be repaired immediately.
4. Every 3 months, thoroughly clean and dry all upper and lower rollers and all hinges. Liberally apply lubricant such as Teflon spray (no grease) on the wheels and bearings of the rollers. Oil all hinges including the hinge pin with light weight lubricating oil or Teflon spray.
5. As with any painted surface exposed to corrosive environments, every 6 months apply a wax to the outside of the painted panel and painted track. If the system includes corner connections make sure the wax penetrates the connection joints.

### **CLEANING AND CARE OF STAINLESS STEEL HARDWARE ON NANAWALL PRODUCTS**

Stainless steel is an inherently corrosion resistant material, but some routine maintenance and cleaning is needed to keep surfaces in good condition so that the aesthetic appearance and corrosion resistance are not compromised.

#### **Initial Cleaning**

It would be best to protect all stainless steel hardware in the construction phase so that there is no damage. However, if there has been exposure, the following is recommended:

Mortar and cement splashes can be treated with a solution containing a small amount of phosphoric acid or a proprietary stainless steel cleaner with phosphoric acid. Rinse with water (preferably deionised water) and dry.

Never allow mortar removers or diluted hydrochloric acid to be used on stainless steel.

Iron particles picked up from tools or from contact with structural steel, etc. must be removed immediately. Steel dust particles created during operations such as welding, cutting, drilling and grinding of carbon steel will rust quickly and must be removed.

At an early stage, light deposits can be removed mechanically using nylon scouring pads, such as those used in the kitchen. Alternatively the contamination can be removed with a proprietary stainless steel cleaner containing phosphoric acid.

### **Maintenance Cleaning**

Stainless steel may be exposed to a wide range of aggressive environments such as coastal salt water, industrial pollutants, salt spray from road de-icing salt and atmospheric dirt. All cause brown staining to appear. During routine cleaning of at least every month and more frequently if necessary, all accumulations of airborne contaminants, such as airborne chlorides, salt or sulfur oxides, should be removed. In less aggressive environments, cleaning can be less frequent, such as every 3-6 months. Also finger marks should be routinely removed.

To remove fingerprints and other marks, soapy water or a mild detergent are usually safe and successful.

For more stubborn stains, mild household cream cleansers should be effective. This should also be suitable for cleaning off watermarks and light discoloration. After cleaning, remove the residues with deionised water and dry to avoid streaking and water marks.

Nylon pads can be used (such as those from 3M). When using nylon pads make sure you follow the original grain of the stainless steel surface. Maintain rubbing in a

straight line or the surface will appear scratched rather than grained. DO NOT use cleaning steel wool, wire brushes, metal scouring pads, hard scrapers or knives as the underlying stainless steel surface may become scratched or unwanted contaminants may be deposited on the surface of the stainless steel. To avoid "cross contamination" from iron particles, ensure that cleaning utensils have not been used to clean other types of steel.

Alternatively, use a proprietary stainless steel cleaner containing phosphoric acid to remove contamination, rinse with deionised water and dry. It is advisable that the entire surface is treated so that a patchy appearance is avoided.

Cleaners that should not be used on stainless steel include chloride-containing cleansers, especially those containing hydrochloric acid, hypochlorite bleaches and silver cleaners.

## GLASS INSTALLATION AND GLAZING

This section applies only if you need to install glass for any reason or if glass setting blocks need to be adjusted. Proper glass installation is critical, as, with the NanaWall single track sliding system, glass is a structural part of the panel.

Glass stops and glazing gasket are to be used for “dry” glazing of each panel. Also needed are setting blocks. **Use glass setting blocks with varying thickness made from hard plastic. Rubber setting blocks are not acceptable.** Width of setting blocks should be at least 1/8” wider than the glass thickness and 1/16” to 1/8” less than the width of the glazing pocket. Setting blocks should be about 4” long.

Glass, with appropriate dimensions, thickness and specifications will be needed. Depending on the model, widths of all glass panels may not be equal. Ask NanaWall for the glass dimensions. Please note that glass is required to be fully tempered unless the unit is a window placed above a certain height from the floor. Check with all applicable codes and regulations.

Float glass, including the glass components of insulated glass, shall meet the current requirements of ASTM C 1306 “Standard Specifications for Flat Glass” for quality, thickness and dimensional tolerances. Tempered float glass shall meet the current requirements of ASTM C 1048 “Standard Specifications for Heat-Treated Flat Glass - Kind HS, Kind FT Coated and Uncoated Glass.” All tempered glass shall have a permanent logo, which signifies Safety Commission 16 CFR-1201 and the safety glass test requirements of ANSI Z 97.1 (current editions). Insulating Glass shall meet the requirements of ASTM E 774, Class A, B or C.

Although glass installation with the “dry” glazing system is relatively straight forward, it is recommended that an experienced glazing contractor be used.

It is **very important** that the bracing direction and placement of glass setting blocks be correct. Setting blocks for swing panels are to be placed only at one set of opposite diagonal corners whereas setting blocks for individual sliding panels are placed at all four corners. For swing panels, setting blocks are placed at the upper corner on the side where the handle is and at the lower corner on the side where the hinges are. If not correctly braced, the unit will not operate properly. See Diagram 1 for an example with a typical 4 panel unit.

Follow all proper applicable glass installation and glazing techniques as recommended in the Flat Glass Marketing Association (FGMA) “Glazing Manual” and “Sealant Manual”. Always use suction cups to shift glass within an opening. It would be best to install the glass on the panels before they are installed in the opening. Panels can be laid flat on sawhorses. If the panels are already installed, they can still be glazed.

1. Close all panels and secure them with the multiple lock bolts. Start with a panel on one side.
2. Remove all glass stops on the panel. Be sure to protect the finish.
3. Measure both the vertical and horizontal dimensions of the glass and the panel opening. Subtract the vertical glass size from the vertical panel opening size. Divide the difference by two. This will give the nominal thickness of the setting block to use at the top and bottom rails. Several setting blocks of different thickness may need to be combined to obtain the desired thickness. Do the same for the horizontal dimension to obtain the thickness of the setting block to use at the stiles.
4. If it is a swing panel, place a setting block (or combination of setting blocks with desired thickness) on the bottom rail of the panel opening such that it is about 2” from the bottom corner that is on the same side as the hinges.



Carefully place the glass in the opening, making sure it rests on the setting block. With insulated glass, make sure that both inner and outer panes are supported evenly.

Place a second setting block in the same corner as the first, but in the vertical direction along the stile such that its edge is about 2" above the corner.

Place the third setting block in the upper diagonal corner vertically on the opposite stile in the same manner. Then place the last setting block for a swing panel on the upper rail on the same corner as the other upper setting block. To get a proper fit, shift the glass weight by lifting the glass panel up with a plastic pry bar at the lower corner below the upper setting block. These setting blocks should all fit snugly but should not be forced. Adjust the thickness of the glass setting blocks such that the panel is slightly out of square. The upper corner with the setting blocks should be about 1/16" to 1/8" higher than the other corner.

5. For an individual sliding panel, place setting blocks on the bottom rail about 2" from the bottom of each corner. Carefully place the glass in the opening, making sure it rests on the setting block. With insulated glass, make sure that both inner and outer panes are supported evenly.

Then place setting blocks in these corners in the vertical direction along the stile such that its edge is about 2" above the corner, proceed in the same manner on both upper vertical corners. For an individual sliding panel, place setting blocks on both corners of the upper rail.

**If necessary, apply a little adhesive that is non-damaging to the glass edge seals such as Dow Corning 791 silicone, to keep the vertical setting blocks from slipping. Make sure that the drainage in the panel is**

**not obstructed by adhesive or glass setting blocks. If the panels are large (over 8 feet tall), additional setting blocks are needed midpoint on the stiles, especially on a swing panel. Ensure that these blocks have the correct thickness and the vertical stiles are still parallel and not bowed.**

6. For aluminum systems insert the glass stops so that they snap into the panel profile. For wood systems insert the glass stop firmly into position, so they are flush with the panel. Nail to the inner side of the panel with small finish nails. Start with the top and bottom stops and then the sides.
7. Insert the glazing gasket in the space between the glass and the glass stop. First, cut the gasket to a length a little longer than the actual length of the glass stop because gasket material may shrink at low temperatures. Do not stretch or pull the gasket in any manner. If necessary, use soapy water to lubricate the gasket to make insertion easier.
8. Make sure that the stops are locked firmly and securely into position and are flush with the rest of the panel profile.
9. After installing the panels, assuming that the head jamb and sill are level, check to see if the gap between the panel and head jamb and panel and sill is even across the width of the panel. With the glass weight, the out of square swing panels should become almost even. If they remain slightly higher in the upper corner with the setting blocks it is okay. If not, then the lower and upper setting blocks thickness need to be adjusted. Panels have to be braced correctly for proper operation.

**DIAGRAM 1: EXAMPLE WITH A TYPICAL 4 PANEL UNIT**

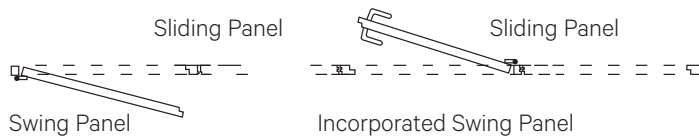
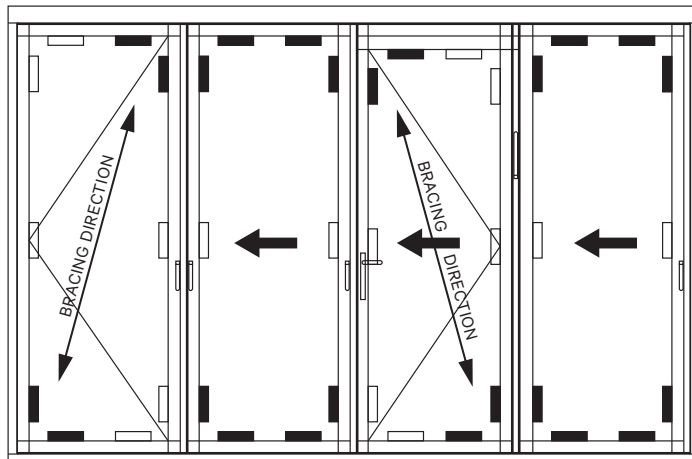

- Setting blocks for tension
- Setting blocks to keep distance

# NanaWall Limited Warranty

---

NanaWall is pleased to provide the following product warranty for the owner of the property within which NanaWall products have been installed, subject to all terms and conditions stated herein.

## TEN YEAR COVERAGE

**Insulated Glass.** The insulated glass provided by NanaWall is warranted to be free from a permanent material obstruction of vision due to a premature failure of the glass seal for 10 years from the date of delivery (“Delivery”). Exception: for zero by NanaWall, please see Five Year Coverage.

**Powder Coat or Baked on Fluoropolymer Surface Finish of Aluminum Profiles.** Powder coat or baked on fluoropolymer surface finish of aluminum profile is warranted to perform for a period of 10 years from Delivery as an Effective Surface Material (ESM). ESM means: (1) free from substantial cracking, chipping or peeling due to the deterioration of the finish, exclusive of mechanical damage; (2) free from chalking in excess of a numerical rating of 8 as per ASTM D 659; and (3) free from fading or color changes in excess of 5 NBS units as per ASTM D 2244. Because surfaces may not be equally exposed to the sun and elements, NanaWall makes no warranty with respect to the uniformity of fading.

**Rollers.** The rollers in NanaWall product are warranted to be free of manufacturing defects in material and workmanship that significantly impair proper operation and function for 10 years from Delivery.

**Wood and Other Remaining Components.** Where product is installed by a NanaWall Certified Installer, all remaining components of NanaWall products not otherwise addressed in this Warranty are warranted against defects in materials and workmanship that substantially impair operation and function for a period of 10 years from Delivery. This includes, but is not limited to, wood frame components, hinges, handles, locking mechanisms, tracks, and weather-stripping.

## FIVE YEAR COVERAGE

**Laminated Glass.** The laminated glass in NanaWall products is warranted to perform for five (5) years from Delivery against a permanent material obstruction of vision due to premature delamination.

**Wood and Other Remaining Components.** In the event that product is not installed by a NanaWall Certified Installer, the coverage period for Wood and Remaining Components addressed above is reduced to five (5) years from Delivery.

**Insulated Glass for zero by NanaWall.** The insulated glass provided for zero by NanaWall is warranted to be free from a permanent material obstruction of vision due to a premature failure of the glass seal for five (5) years from the date of Delivery.

## THREE YEAR COVERAGE

**Anodized Surface Finish of Aluminum Profiles.** Anodized surface finish of aluminum profile is warranted to perform for a period of three (3) years from Delivery as an Effective Surfacing Material.

## ONE YEAR COVERAGE

**NanaWall Shades, Screen ONE, Screen Classic, and Other Screens Sold by NanaWall.** All screens, excluding the screen mesh, are warranted to be free of manufacturing defects in material and workmanship for a period of one (1) year from Delivery.

## WHAT NANAWALL WILL DO

NanaWall shall have no obligation to respond under this Warranty until receipt of proper notice of a claim during the warranty period and an opportunity to respond. Upon proper notice and confirmation by NanaWall of a condition covered under this Warranty, NanaWall shall respond in its sole discretion and in a timely manner as follows:

**Glass.** NanaWall shall (1) ship a replacement glass unit to the location of original product delivery or (2) refund the original purchase price of the glass paid by NanaWall.

**Surface Finishes of Aluminum Products.** NanaWall shall (1) assume reasonable costs to restore the finish on non-compliant (non-ESM) materials using standard commercial refinishing techniques; (2) ship replacement parts to the location of original product delivery; or (3) refund the original purchase price of the non-compliant product.

**Rollers.** NanaWall shall ship replacement rollers to the location of original product delivery.

**Screens.** NanaWall shall (1) ship replacement screen product to the location of original product delivery; (2) repair any screen without charge; or (3) refund the original purchase price of the screen.

For covered product conditions not specifically addressed above, NanaWall's obligations under this Warranty shall be limited, at its option, to: (1) ship a replacement part or product without charge; (2) ship any replacement part or replacement product in its original stage of fitting and/or finishing as supplied by NanaWall; or (3) refund the original purchase price of the product.

NanaWall will repair or replace only defective parts or components. This Warranty does not cover labor costs to install a replacement part or product, or cost to repair or replace surrounding substrates, trim, or other carpentry work. Nor does it cover costs incurred due to delays or other construction costs, costs for late or damaged delivery, loss of time, inconvenience, or loss of use of the product or any parts or components. Any action taken by NanaWall does not create a new warranty or extend the duration of the original product warranty. A failure by NanaWall to enforce a warranty provision shall not constitute a waiver barring subsequent enforcement.

Replacement products will be the closest equivalent current product and may not be an exact match to the original. NanaWall reserves the right to determine whether or not a defect exists and if it is covered under this Warranty. Repair or replacement of warped wood panel or frame can be delayed by up to 12 months from date of claim to allow wood component to adjust to local conditions. If the claim is not covered under this Warranty, NanaWall may charge a fee for on-site product inspections.

## **NOTICE PROCESS**

Written notice of any claim under this Warranty with supporting documents such as photos or videos must be given to Nana Wall Systems, Inc., 100 Meadowcreek Drive, Corte Madera, CA 94925, promptly when discovered. All rights under this Warranty will be waived if there is a failure to notify NanaWall within 30 days of receipt of the product for any defect which an ordinary inspection would reveal, or if there is failure to make a claim within a reasonable time during the warranty period after a hidden defect is discovered.

## **DISCLAIMERS & LIMITATIONS**

Any liability of NanaWall is contingent upon owner fulfilling its notice obligations as stated in this Warranty. Owner shall have no standing to assert a claim absent timely notice to NanaWall and an opportunity to cure. The remedies prescribed in this Warranty are the exclusive and sole remedies available to owner. In no event shall the liability of NanaWall or any seller of NanaWall products arising out of a product defect exceed the price paid for the product.

This Warranty is the sole warranty for NanaWall products. **ALL OTHER WARRANTIES, EXPRESS OR IMPLIED, INCLUDING ANY WARRANTY OF MERCHANTABILITY OR FITNESS FOR A PARTICULAR PURPOSE, ARE DISCLAIMED. NANAWALL SHALL NOT BE LIABLE FOR CONSEQUENTIAL OR INCIDENTAL DAMAGES.** Where disclaimer of implied warranties is prohibited by law, the duration of any implied warranties is limited to the duration of this Warranty. Some states do not allow limitations on how long an implied warranty lasts, so the above limitation may not apply to you. This Warranty gives you specific legal rights, and you may also have other rights which vary from state to state. No one is authorized to make any different or additional warranties.

The warranties detailed in this document are the only statements of the legal responsibility of NanaWall and any seller of NanaWall products with respect to covered NanaWall products manufactured on or after November 30, 2015, sold by NanaWall and installed in the United States (50 states only) or Canada only.

**OTHER WARRANTY LIMITATIONS**

This Warranty does not cover damage or conditions caused in whole or part by:

- Improper selection, application, storage, handling, modification, installation, or waterproofing; Movement of surrounding substrates; Failure to properly install product according to NanaWall's instruction or to integrate product into the structure to prevent water intrusion; Failure to prevent the effects of sheeting rain or water or failure to provide an appropriate flashing system; Failure to meet code or specification requirements.
- Improper finishing, including, but not limited to, not properly finishing all sides of wood products in a timely manner or before exposure to weather, finishing exterior wood in dark colors, or not refinishing periodically; Failure to immediately repair any breaches such as scratches, chips or abrasions in any finish.
- Product installed within close proximity of any coastal area or body of salt water; Filiform corrosion in coastal environments, tarnish, or corrosion to hardware finishes; Product installed in other harsh or corrosive environments, including near swimming pools or where subjected to harsh chemicals such as road salt, solvents, acid, brick or mortar wash, or cleaning chemicals.
- Normal weathering, wear and tear; Discoloration of finish; Failure to follow the NanaWall operation and maintenance instructions; Failure to operate the product for more than one month; Failure to clean and maintain aluminum surfaces in accordance with AAMA 609 and 610 or not maintaining adequate cleaning records.
- Imperfections in glass that do not affect the product's structural integrity or obscure vision and cannot be detected from within 10 feet as per ASTM C 1036; Accidental or spontaneous glass breakage; Glass breakage due to thermal stresses; Film applied to the glass surface; Industry accepted bow, warp or distortion in glass and minor variations in glass color; Glass not installed as per NanaWall's instructions.
- Variations in wood grain or color; Warp within the allowable warp tolerance for wood panels per ANSI/WDMA I.S. 6-A-01; Warpage on wood panels caused by leaving panels in the open position exposed to the elements or not engaging the locking points properly when in the closed position; Resin bleeding from wood panels.
- Panel shrinkage or expansion caused by change in weather; Expansion of aluminum units in dark colors caused by direct exposure to sunlight.
- Acts of God, falling objects, fire, accidents, external forces, or other conditions beyond NanaWall's control.
- The amount of argon or other gas remaining in insulated glass at any time after manufacture; Condensation, frost or mold caused by high interior relative humidity.
- Performance of product in conformance to any published NanaWall testing results in terms of air and water infiltration and structural loading. These results measure the performance of a single sample of the product of a certain size and configuration. Performance in the field may change over time depending upon the conditions of handling, installation, use, and maintenance.
- Products or components not supplied by NanaWall; Products that have not been paid for in full; Products ordered in larger sizes or special configurations beyond NanaWall's published specifications.

# NanaWall Warranty Registration

Must be filled out and returned to the address printed at the bottom of this form within 30 days from date of purchase of the NanaWall in order for the limited warranty to become effective.

**NANAWALL ORDER #** \_\_\_\_\_ **PROJECT NAME** \_\_\_\_\_

Date of Purchase \_\_\_\_\_ Purchaser Name \_\_\_\_\_

## PROPERTY OWNER

Name \_\_\_\_\_ Address \_\_\_\_\_

Telephone \_\_\_\_\_ E-mail \_\_\_\_\_

Project Address (if different from above) \_\_\_\_\_

## INSTALLATION

Installer Name \_\_\_\_\_ Address \_\_\_\_\_

Telephone \_\_\_\_\_ E-mail \_\_\_\_\_

Type of project  new residential  restaurant  shopping mall  
 residential remodel  office building  other \_\_\_\_\_

Architect Name \_\_\_\_\_ Address \_\_\_\_\_

1. Is the installation complete?  yes If yes, date completed \_\_\_\_\_

no If no, date scheduled \_\_\_\_\_

2. Have you been shown how to operate your new NanaWall?  yes Is operation satisfying?  yes  no

no Why not? \_\_\_\_\_

Signature \_\_\_\_\_ Date \_\_\_\_\_