



Owner's Manual

NanaWall WD65

Wood Framed Top-Hung Folding System

This Owner's Manual contains instructions on the installation, operation, maintenance and warranty of the NanaWall WD65 Wood Framed Top-Hung Folding System. This manual is to be used by the installer for installation and is to be kept by the Owner for reference. Replacement parts can be ordered directly through NanaWall Systems.

Installation Instructions

The installation of the WD65 System requires a working knowledge and experience in the use of tools, equipment, and methods necessary for the installation of aluminum doors, windows, storefronts, and/or partitions. This practice assumes a familiarity with preparing a proper and structurally sound opening, proper anchorage, waterproofing, caulking, and sealing and assumes an understanding of the fundamentals of building construction that affect the installation of large door systems.

Highly recommended is using an independent NanaWall Certified Installer, if available, or, at least, an installer who has some experience in installing NanaWall systems.

IMPORTANT: READ COMPLETE INSTRUCTIONS BEFORE BEGINNING INSTALLATION. INSTALL AS RECOMMENDED; OTHERWISE, THE UNIT MAY NOT FUNCTION PROPERLY AND ANY WARRANTY, WRITTEN OR IMPLIED, WILL BE VOID.

CAUTION:

As regulations governing the use of glazed windows, doors, storefronts, and/or partitions vary widely, it is the responsibility of the building owner, architect, contractor, or installer to insure that products selected conform to all applicable codes and regulations, including federal, state, and local. NanaWall Systems, Inc. can assume no obligation or responsibility whatsoever for failure of the building owner, architect, contractor, or installer to comply with all applicable laws and ordinances and safety and building codes.

The WD65 system is shipped with all necessary components. However, not included are screws, bolts, shims, etc. to anchor the unit to the rough opening.

The frame is shipped knocked down and needs to be assembled. Panels are pre-assembled with or without glass, ready to be attached to the installed frame. In most cases, all hinges, weather stripping, multiple locking, and flat handles are pre-attached to the panels and frame components.

DESCRIPTION OF SUPPLIED PARTS

Check all parts carefully before assembly. Depending on the model, some of these parts may already be pre-installed on the panels. Check that the sizes of the frame components and panels match with what was ordered. In the small cardboard box attached to the frame components that contains hinge pins and various hardware, inspect the elevation drawing, indicating size, configuration, and labeling of the unit ordered. For orders with multiple units, do not mix and match panels and frames, even if two units are exactly the same. Below is a list of supplied parts

Always looking from inside.

- Left side jamb, labeled L, and right side jamb, labeled R.
- Head jamb, labeled O, and sill, labeled U. (In some instances the head jamb and sill may be in segments.)
- Pre-assembled panels: rollers, guides, and locking mechanism with flat handles are installed on the panels. The number of panels depends on the model ordered. **The sequence of labeling of panels starts from the left with the left most panel labeled Panel 1.** If supplied unglazed, panels have to be glazed before being installed in the opening. See Appendix A: Glass Installation and Glazing.
- A certain amount of hinge pins and set screw to secure the hinge pins.

- Lever handles, other handles or other entry hardware as ordered. These may be pre-attached to the panels.
- Panel holder – one for each swing door not attached to a side jamb.

HANDLING OF COMPONENTS

1. Upon receipt, inspect the shipment to ensure it is in good condition.
2. Make sure that the small cardboard box with the hinge pins and other hardware does not get lost.
3. Store in a clean and dry location and protect against defacement or damage, especially to the edges of panels.
4. Wood components should not be subject to extreme or rapid changes in heat or humidity, such as forced heating to dry out a building.
5. **All wood surfaces including all edges (top, bottom and sides) should be completely sealed and finished promptly.**

PREPARATION OF THE ROUGH OPENING

For necessary clearance and adjustment space, make rough opening about 3/4" wider and 3/8"- 1" higher than the outside frame size of the unit ordered (check to comply with applicable codes for maximum shim space allowed, especially in high windload areas). It is important that the opening be the correct size. Note that the outside frame height of the unit ordered is measured from the bottom of the sill and not from the finished floor. Allowance must be made in height for the portion of the sill that is below the measured opening.

IMPORTANT: Because of the large opening sizes and the weight and movement of the panels, any application should take into consideration the following:

1. The structural integrity of the header is critical for proper operation. Vertical deflection of the header under full live and dead loads should be the lesser of $L/720$ th of the span and 1/4". Structural support for lateral loads (both windload and when the panels are stacked open) must also be provided.
2. A qualified engineer or architect should be used to determine the proper construction details and header to be used in your particular application.
3. **THE ROUGH OPENING SHOULD BE LEVEL, PLUMB AND SQUARE AT ALL POINTS. THERE SHOULD BE NO UNEVENNESS OR BOWING. MAKE SURE THAT THE HEADER IS NOT TILTED OR TWISTED. THERE SHOULD BE NO BUMPS ON THE FLOOR. THE SIDES SHOULD BE IN THE SAME VERTICAL PLANE AND NOT OFFSET OF EACH OTHER. A TRANSIT AND OTHER SIMILAR PRECISE MEASURING EQUIPMENT SHOULD BE USED.**
4. With a recessed sill, if concrete is to be poured after the installation of the unit, the sill has to be securely attached to the construction. If the sill is to be cast in concrete, then an expansion gap with appropriate material has to be created next to the sill.
5. With a low profile saddle sill, some resistance to water infiltration may be achieved by installing drain connections to the outside.

If any anchorage or drain connection holes are made through these drain channels, make sure that they are properly sealed to prevent any water leakage. The open ends of these drain channels at each end of the sill should also be properly sealed. Alternative anchoring systems for the sill (without using screws through the drain channels) are using L brackets attached to both sides of the sill.

6. For better performance and protection, any exterior folding system should be installed under an overhang or with other similar protection.
7. For better performance it is recommended that all dead loads such as upper levels, roof, etc. be constructed before a unit is installed.

Properly flash and waterproof around the perimeter of the opening, especially at the sill. Make sure you seek proper professional advice for the appropriate construction needed for your particular application. **DO not** install unit in structures that do not allow for proper management/drainage of moisture.

To avoid future problems, do not install your unit until the rough opening has been correctly prepared.

WOOD FINISHING AND MAINTENANCE RECOMMENDATIONS

NanaWall wood framed systems are shipped with a factory applied layer of a water born translucent coat of sand sealer or primer, which is an acrylic-copolymer-dispersion from Sikkens (www.nam.sikkens.com). NanaWall aluminum clad wood framed systems are shipped with a similar additional coat. **These factory applied coatings are not a sufficient and adequate protection from the elements and at least two coats of a final finish need to be applied in the field.**

IMPORTANT: Immediately upon receipt of the unit and prior to installation and exterior exposure to weather elements, all wood surfaces including all edges (top, bottom, and sides) should be completely sealed and must be protected with a good quality finish. *Before installation, keep the units in a dry and clean location, store and stack them properly to avoid twisting or warping of the panels and frame components.*

To complete the wood surface treatment **use compatible finish material**. If you think the product that you are intending to use is not compatible, then completely remove all pre-applied coats by chemical stripping (please follow the direction of the product) or by sanding off. Do not use power wash or excessive water. Then apply a good quality sealer or primer and continue applying the necessary coats as recommended by the product you have chosen.

CAUTION:

Not all available paints and stains, nor the customer's specific application requirements can be evaluated. Your local paint professional should know of suitable finish systems that give satisfactory results in your region. It is

highly recommended that top quality finishes be selected, and the directions of the products be followed explicitly.

In general, the surface must be prepared by cleaning off dust and any debris. With 180-220 grit sandpaper, sand lightly and thoroughly all surfaces to be painted. Do not use steel wool or silicon carbide type sandpapers. Then clean the surfaces before applying paint, etc.

For best performance, a minimum of two topcoats should be applied.

Always make sure that you apply the coatings on a hidden area before finishing the whole unit to make sure you are satisfied with the results.

Ensure not to apply the coating material on to hardware, gaskets, glass, sealant, or aluminum surfaces to maintain proper product performance.

All damages or scratches during installation on the surface coating should be immediately touched up.

WOOD SIMULATED DIVIDED LITES (SDL)

It is recommend that after completing the surface treatment of the SDL and after allowing for adequate drying time, to seal the gaps between the SDL and glass with a durable weather resistant caulking material, which is compatible with the surface treatment material.

MAINTENANCE OF WOOD UNITS

As a general guideline it is recommended that every 1/2 year or earlier, to inspect visually the surface and if necessary re-finish in the same manner as per instructions above . The timeframe may vary on weathering, exposure conditions and altitude. Whenever damage is visual, it should be repaired immediately.

UNIT INSTALLATION

The Installation of the folding unit is described in the following categories:

- A. FRAME ASSEMBLY AND INSTALLATION
- B. PANELS AND FOLDING HARDWARE INSTALLATION
- C. FINAL STEPS

A. FRAME ASSEMBLY AND INSTALLATION

It might be easier to drill the holes as described in Step A6 before assembling the frame.

Step A1

Lay the four frame components flat on the floor and align the ends to be joined. *If the head jamb and sill regarding their length provided in segments, then connect them first. If a unit has angle changes in the floor plan, then separate information will be supplied.* Make sure that the frame components are in the correct positions. The frame should be labeled U for sill, O for head jamb, and looking from inside, R for right side jamb and L for left side jamb. Note: If there are no weep holes in the sill, please check whether such holes are required and drill them if necessary. Please be careful to avoid scratching or damaging the components.

DIAGRAM 1: WD65 EXAMPLE OF A 3 PANEL UNIT INWARDS OPENING.

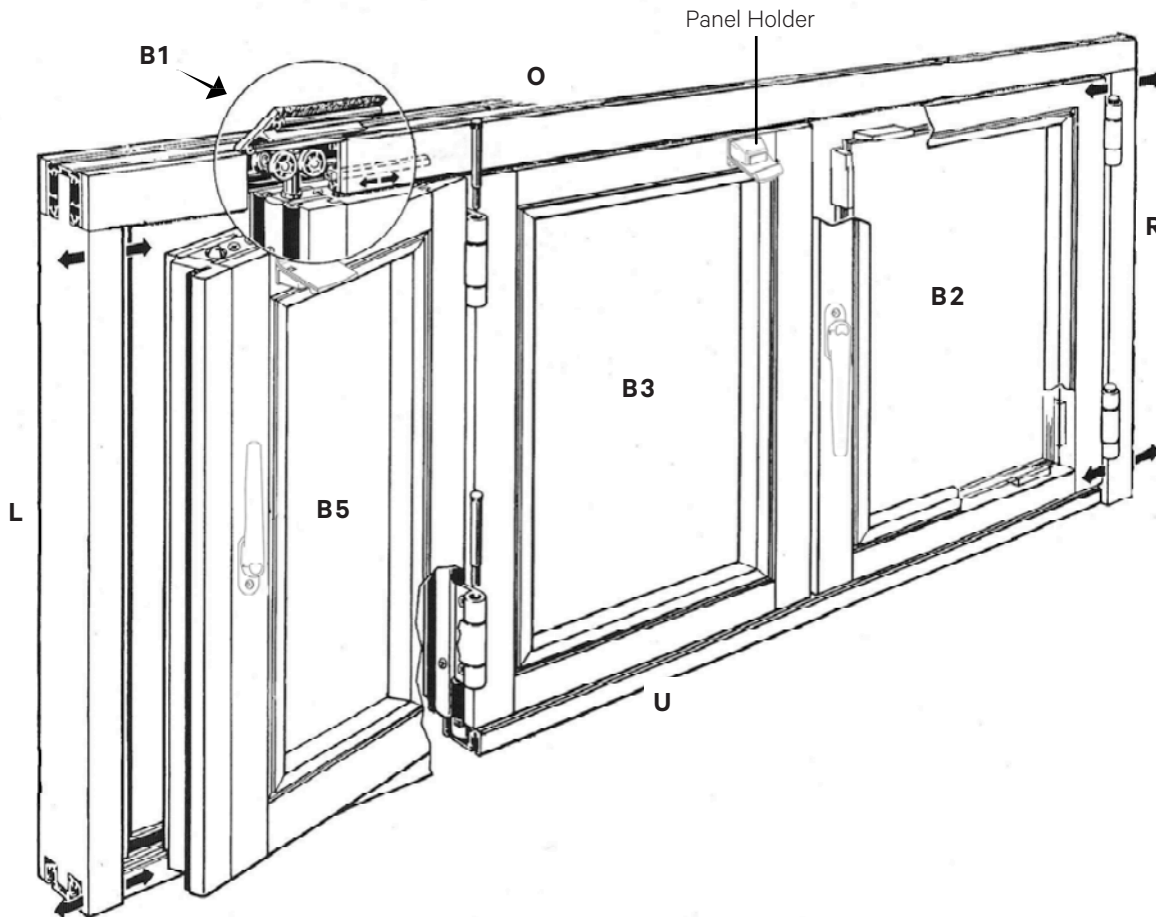

Step A2

Assemble all frame parts as shown in **Diagram 1**. Do not apply sealant to the corner joints yet.

Step A3

Do not screw the vertical side jambs to the head track nor the sill. It has to be possible to slide the side jamb inwards or outwards for adjustment.

Step A4

Be sure that appropriate flashing around the perimeter of the opening is installed. Set the assembled frame into the rough opening at the proper position relative to the header. Make sure the direction is correct with respect to inward or outward opening.

See **Diagram 2** for Suggested Installation Details. Please note that these are suggestions only and that these may not be suitable in all applications.

Step A5

Temporarily secure the frame to the rough opening with clamps.

Step A6

Looking on a standard installation, which is limited to areas with a basic wind speed of not more than 90 mph, in a low rise building (max. 60 feet roof height), Exposures B or C and a non critical status. Fasteners locations should start about 4" from the interior edge, drill holes for the anchorage devices to connect the frame to the opening at a spacing of not more than every 16" along the head jamb and the sill. On the head jamb and sill an additional fastener should be placed at the meeting point of panels in the closed position and anchorage points every 4" in the stacking area on either side. The spacing of the side jamb should be about 14" starting at the bottom, using an extra screw at the top. **For installation that are beyond the above limitations, a structural engineer should be consulted for specific fastening requirements.**

Use appropriate screws or other equivalent anchorage devices depending on the adjacent substrate material and construction. Make sure they are corrosion resistant. Anchorage devices should penetrate or hold sufficiently to the opening to withstand necessary structural loading. Generally, for wood frame use #14 (1/4" diameter) wood screws with 2-1/2" minimum embedment, for concrete with a minimum compressive strength of 3,200 psi use 3/16" diameter ITW Tapcons (concrete screws) with 1-1/4" min. embedment. For masonry use 1/4" diameter ITW Tapcons (masonry screws) with 1-1/4" embedment. Standard installation into light gage steel substrates with a minimum of 18 gage (0.0451" thick) should have 1/4" diameter type 410 stainless steel self drilling screws. Into structural steel substrates thicker than 1/4" should be pre-drilled and 1/4" diameter SAE Grade 2 bolts can be used. Another option is to use type 410 stainless steel self drilling screws. For this option first drill small pilot holes.

Make sure that the screw head with washer (if any) is small enough to fit inside the slot in the middle of the head jamb and sill; otherwise, it will interfere with the rolling of the running carriages.

Anchor through the center of the groove but make sure the screw or bolt head with washer bears on the aluminum. To maintain the thermal break, use PVC or nylon washers so that the screw heads do not bridge the aluminum.

Make sure that the frame is level, plumb and square at all points. There should be no unevenness or bowing. If, for any reason, the floor is not level, shim with plastic horseshoe shims to the highest point of the floor, provided there is still enough clearance at the top. Place plastic, horseshoe type shims tightly at every fixing point between the frame profile and rough opening. **Use hard plastic horseshoe shims only.**

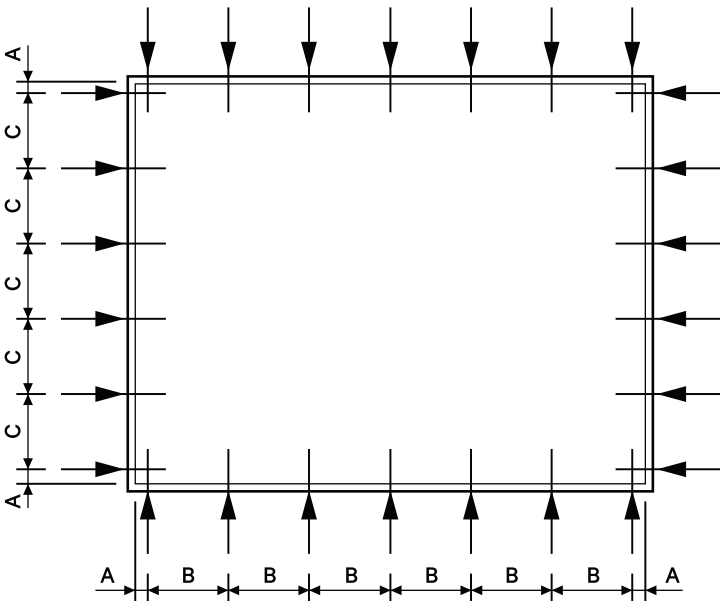

DIAGRAM 3:
SUGGESTED FRAME FASTENING POINTS

- A = About 4" from the interior edge.
- B = Distance about 16", except at the stacking area on one or both sides where spacing should be about 4". Plus extra screws at meeting point of panels.
- C = Distance about 14" from the bottom using extra screw at top.

Step A7

Anchor the sill to the sub floor in correct relation to the finish floor. Make sure that the sill is not tilted or twisted. Make sure that all holes drilled through the sill are properly sealed with silicone underneath and around the screws.

All weep holes in the sill are not to be obstructed.

Make any necessary adjustments to level, plumb, and square before proceeding on.

Step A8

Anchor the side jambs to studs or walls in the same manner. Make sure that the jambs are plumb and straight.

Step A9

Anchor the head jamb through the pre-drilled holes and shims. Make sure that the head jamb is level.

IMPORTANT: Make sure no shims are forced to ensure that frame sections are not bowed. Check frame constantly to be certain that it is level, plumb and square. A transit and other similar precise measuring equipment should be used to make these determinations.

Step A10

IMPORTANT: Make sure that all the surfaces of the upper and lower tracks are clean and free of any debris, especially, cuttings from drilled holes.

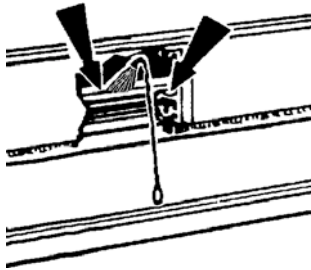

DIAGRAM 2: WD65 SUGGESTED TYPICAL INSTALLATION

Suggested Typical Installation drawings shown are very general and may not be suitable for any particular installation. Product placement, fasteners, flashing, waterproofing, sealant, trim, and other details for specific surrounding conditions must be properly designed and provided by others.

Drawings not to scale. Details shown are subject to change without notice.

Note: Contact us for detailed information.

INWARD AND OUTWARD OPENING DETAILS

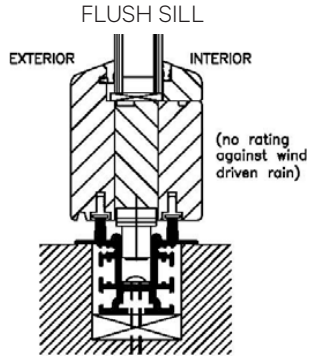
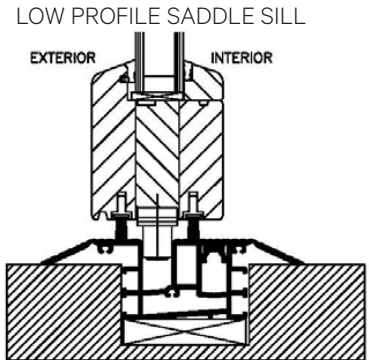
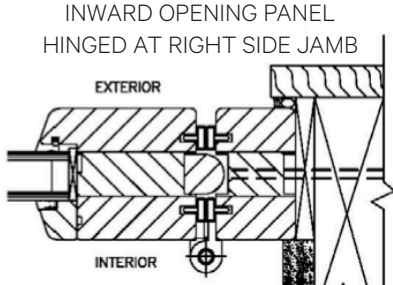
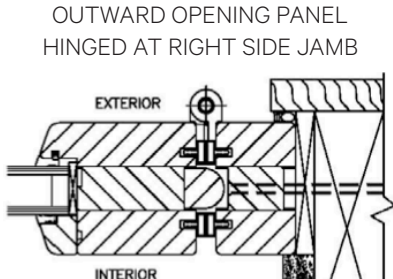
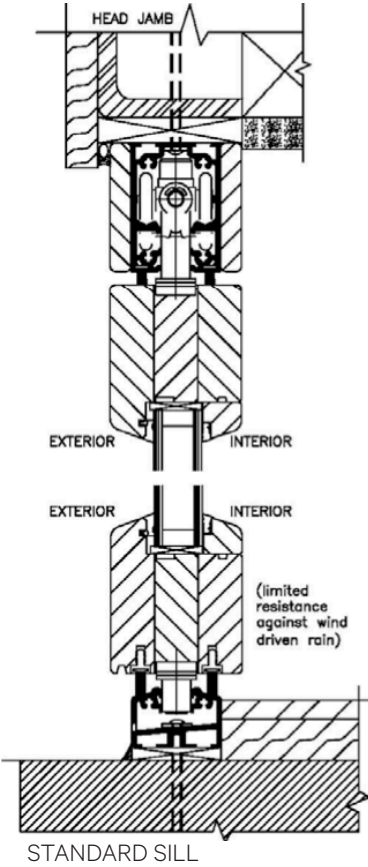

LOW PROFILE SADDLE SILL
For some level of water resistance, recommend the following by others:

1. Remove the gasket covering inner water channel.
2. Provide necessary weepholes at bottom of channel and an outside face of sill.

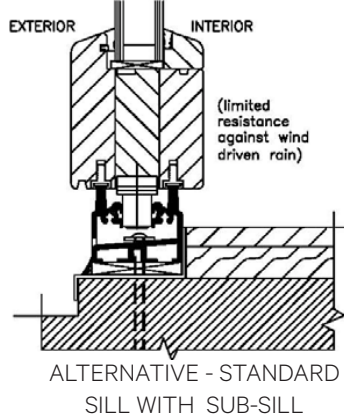

To adjust for difference in floor levels, sill flange is bendable or removable (in the field).

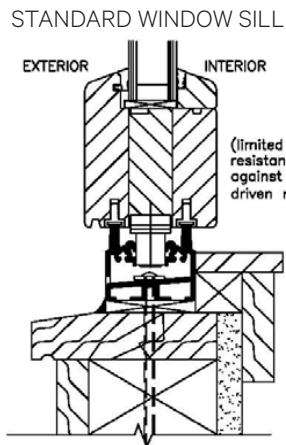
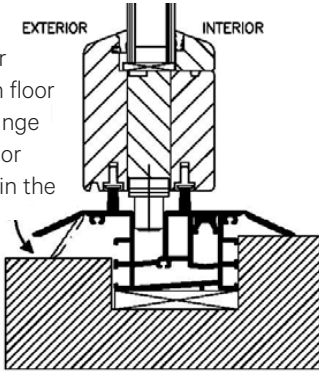

B. PANELS AND FOLDING HARDWARE INSTALLATION

IMPORTANT: Look for glass stops to determine the interior side of a panel.

Step B1

Looking at the elevation drawing, note where the installation slot in the head jamb is located. The slot can be accessed by the removal of the approx. 12" small piece of wood trim on the head track. Reach into the track to slide the rod and open the plate. **See Diagram 1.**

Step B2

Start with the panel furthest away from the slot. If it is to be hinged off the side jamb, align the hinges and insert the proper hinge pins.

Do not force any hinge pins and do not hammer them all the way in, let the knurling stick out.

If it is part of unhinged paired panels not hinged to the side jamb, set lower guide that is pre-attached to the bottom of the panel, in the lower track. Insert the upper running carriage roller that is pre-attached on top of the panel, through the slot in the head jamb.

Step B3

Again, looking at the elevation drawing, attach the next panel needed to create a folding pair. Set the guide in the lower track and insert the roller through the slot in the head track. Slide the panel and align the hinges with the first panel. Insert the hinge pins to create a folding pair. If necessary, place temporary blocks under the panels to assist in keeping the panels in a steady position.

After installation of each panel, check to make sure that the panel is vertically straight.

Step B4

If there are additional panels to be attached to the folding pair, close the pair by turning the handle 180°.

Step B5

Attach additional panels in the same manner.

C. FINAL STEPS

Step C1

Attach handles and other hardware that have not been pre-attached. Attach the profile cylinder (if any) to the locking gear by inserting it into the lock hole and attaching the set screw through the screw hole on the gear located at the edge of the panel. Cut the set screw, if needed, so it is not longer than 1-1/2" to 2" depending on locking type.

Step C2

IMPORTANT: For swing panels not attached to a side jamb, attach the panel holder to the top of the upper rail of the adjacent panel. See Diagram 1. Follow the specific instructions that are on the sheet in the panel catch kit. The purpose of this is that the swing panel should always be opened and engaged into the panel holder before the folding panels are to be opened.

Step C3

Close and lock all panels into position.

Step C4

Check all horizontal joints:

Make sure the head jamb and sill are still level. Then along the entire width of the opening, check the spacing between the sill and each panel and the spacing between the head jamb and each panel. Both spaces should be about 5/16" along the entire length of the unit.

Check especially to see if the upper corner of a panel where the running carriage is located is not higher than the other corner of the panel. If it is slightly lower (not more than 1/16"), it is okay. **Proper spacing is critical for proper operation of the unit.**

Step C5

Check all vertical joints:

Make sure that the side jambs are still vertically straight. All vertical spacing between side jamb & panel rebate and the join where swing panel meet swing panel should be 5/16", spacing between panel and panel should be 3/8".

Step C6

Adjustments can be made by sliding the vertical jamb. See Diagram 1.

Step C7

Check that the system operates and functions properly. The panels should be able to be moved easily by one person without much effort (for not more than 6 panels to one side) when opening or closing and all shoot bolts should engage smoothly. If the panels do not move easily or a lot of effort is needed, the indication is that the unit is not properly installed. Correct any problems before finish trimming.

Step C8

Install the hinge pins complete. Again check the operation.

Step C9

Seal the joints [A] on the exterior between the vertical jamb and the sill with exterior grade sealant. Therefore lift the gasket and reinstall and glue it afterwards. Also fill the space [B] underneath the vertical frame and the sill with A exterior grade sealant generous to avoid water leakage into the wall and to protect the wood.

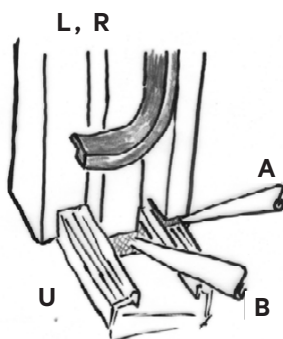
**Step C10**

Apply a thick bead of exterior grade sealant with a backer rod if needed on the joint between the sill and sub floor on both sides along the length of the sill. Do similar for the gaps between the head jamb and side jambs with the opening.

Step C11

For added security on an outward opening unit, on all panels with hinges on the outside, place 2 additional hinges just adjacent to the top and bottom existing hinges on each panel, so the hinge pins on the existing hinges cannot be easily removed.

Step C12

Finish any waterproofing, flashing, trim and sealant needed around the perimeter of the opening. Make sure to leave the installation slot accessible for future maintenance and adjustment.

IMPORTANT: Make sure any weep holes in the sill are not blocked.

Step C13

To prevent uncontrolled movement of the panels when in open position, place appropriate door holder by others as needed.

PROTECTION OF UNIT DURING CONSTRUCTION PHASE

It is important that during the construction phase the unit be kept closed, covered and protected from damage. During this phase, a unit is often subject to the most extreme conditions from all types of construction operations that can permanently damage and destroy it. A unit can be damaged by cement splatter, tar, paint, weld splatter, falling objects, construction dust, sand blasting, etc. All temptations to use the large opening of an installed system for easy ingress and egress by tradesmen should be resisted.

Operation And Maintenance Of NanaWall Products

OPERATION OF A NANAWALL FOLDING UNIT

For opening and closing the folding system, please observe the special notes on the following pages in as far as they relate to your folding system.



When operating the folding system similar to any other door, please do not place your fingers between the panels/pivot points. You may hurt them!

Do not have anyone not properly trained on operation and children operate the unit.

Do not force the system if not operating properly. Please have it repaired as soon as possible by a qualified technician.

Anchor panels when in the open position to prevent uncontrolled movement, especially in windy conditions, that might cause damage and injury.

It is highly recommended that if not used, the NanaWall folding unit be kept closed as much as possible, in order to provide best security and weather resistance. When closed, please engage all locking mechanisms fully.

The correct sequence of opening and closing of panels is dependent on the configuration ordered. Panels must be opened and closed in the right order.

With a Swing Panel Attached to a Folding Pair

1. Open the swing panel a full 180° and connect to the panel catch on the adjacent panel.
2. Disengage the locking points on all the other panels.
3. Slide folding panels, starting with the pair adjacent to the swing panel.

For closing, proceed in reverse order.

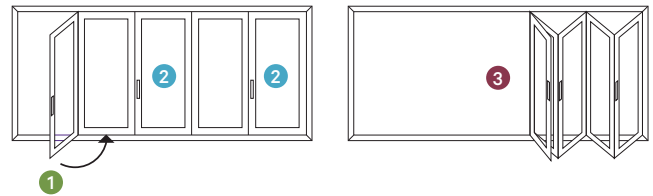

Without a Swing Panel

1. Disengage locking points on primary opening panel pair and fold it slightly.
2. Do the same with any adjacent panel pair.
3. Slide folding panels completely to the side.

For closing, proceed in reverse order.

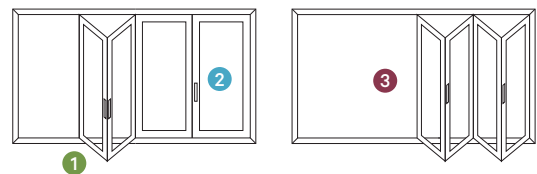

With Unhinged Paired Panels and No Swing Panel

1. Disengage locking points on primary opening panel pair and fold it slightly.
2. Do the same with any adjacent panel pair (s).
3. Slide folding panels into desired stacking position.

For closing, proceed in reverse order.

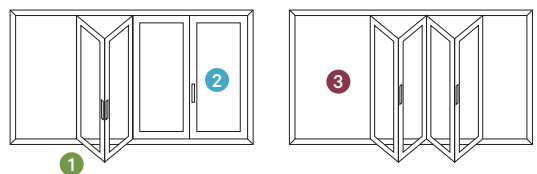

OPERATING THE SL-MULTIPOINT LOCKING ON THE PRIMARY SWING PANEL

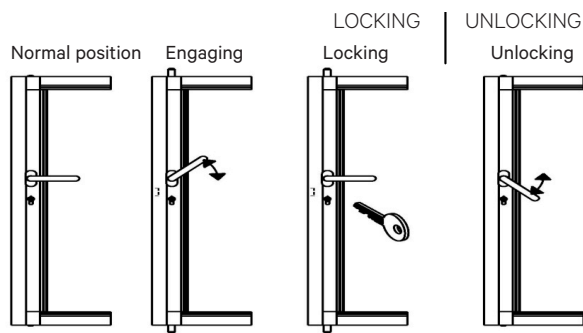

Disengaging locking points
(Note that this is not one motion operation. Key or thumbturn must be unlocked first.)



Be sure to check that the door is locked.
The door is locked, when the handle cannot be depressed.

Engaging the locking points and locking

- Turn handle up about 45° to engage the locking points. Then let it move back into its normal position.
- Only now can it be locked with a key on the outside or a thumb turn on the inside.

Unlock and disengaging the locking points

- Unlock the lock with key or thumb turn.
- By operating the door handle downwards, the locking points at the top and the bottom are disengaged.

RECOMMENDED MAINTENANCE OF NANAWALL PRODUCTS

Some General Considerations on all Projects:

1. It is important that the product is installed correctly. A poorly installed unit will not function properly. This will cause more abnormal force or stress on the components and will lead to premature failure. When operating the unit, the panels should generally be able to be moved easily by one person (except when there are very large panels or when there are more than 6 panels folding to one side). All locking points should engage smoothly. There should be no rubbing on the floor and no binding. When the unit is closed, the reveal between panels and head jamb and between panels and sill should be consistent. There should be no daylight seen from the inside. Please have all problems corrected as soon as possible by a qualified technician.
2. From time to time, due to building movement or settlement, a unit may need to be adjusted by a qualified technician to compensate for any building change.
3. It is important that a unit is operated properly. Locking points should be gently opened and closed and not forced. Panels should be opened and closed in the proper manner and sequence. See the Operation section for proper operation.
4. Periodically check for worn or damaged components and replace as soon as possible. A unit with nonworking components will subject the other components to increased stress and lead to premature failure. A unit with worn or damaged components will compromise the performance level expected for air and water infiltration, structural loading and forced entry.
5. Periodically, inspect the sealant/caulking on the exterior perimeter of the unit. It is extremely important that the sealant/caulking remains intact and in good condition. Trim off any old, loose caulking and seal any gaps with a good quality caulk.
6. Check that all weep holes are clean and clear of any obstructions. Remove debris and other foreign bodies which have dropped into the tracks in the head jamb and sill immediately to prevent damaging the running carriages and guide trolleys. Clean all components as needed.

Check gaskets for proper seating and condition. Remove dust and any deposits from these gaskets.
7. The finished aluminum or wood surface needs periodic cleaning and maintenance. Its appearance may be marred by harsh chemicals, abuse or neglect. Frequency of cleaning depends on exposure and needs. For aluminum surfaces, generally warm soapy water should be sufficient. Stubborn stains and deposits may be removed with mineral spirits. For wood surfaces, superficial surface dirt can be removed by washing with water and a soft-bristled, long-handled brush. Heavier accumulations can be removed with a mild solution of household detergent. For all surfaces, aggressive alkaline or acid cleaners should not be used. Excessive abrasive rubbing should be avoided. Sealants and weather stripping may be affected by strong organic solvents. Superficial damage to the aluminum surface must be touched up immediately with proper touch up paint.
8. If it is a wood product, the surface should be visually inspected every six months or earlier, depending on the exposure of the NanaWall unit. Periodically repaint or restain the wood as needed. Exposure to the environment will break down the finish and compromise its protective features if not refinished.

See Finishing Recommendations in the Owner's Manual of the wood systems.

9. All hardware, hinges and handles should be periodically cleaned with a soft cloth and mild cleanser. Excessive abrasive rubbing should be avoided. Please note that oil rubbed brass is a finish that will develop its own unique patina over time.
10. About every six months, apply lubricant to all the hinges and Teflon spray to the running carriages and guiding trolleys.

SOME SPECIFIC SUGGESTED MAINTENANCE FOR COASTAL SALT WATER AND OTHER EXTREME ENVIRONMENTS:

Please note that the environment within one mile of a sea coast can be extremely corrosive. Products installed in this environment will typically deteriorate sooner than products installed in a less severe environment.

1. Open and close completely a unit at least once a week and inspect all surfaces.
 - a. Salt and other corrosive or abrasive materials such as sand must not be allowed to build up on any surfaces, including all hardware and sill.
 - b. The sill and head jamb tracks should be free from all dirt and debris.
 - c. There should be no standing water in the track in the sill.
 - d. All hardware should be intact and operating properly.
 2. All surfaces must be cleaned with a mild detergent soap and fresh water at least every month and more frequently if necessary.
 3. Any breaches in the paint coating, such as scratches, chips or areas of abrasion, must be repaired immediately.
 4. Every 3 months, thoroughly clean and dry all upper and lower rollers and all hinges. Liberally apply lubricant such as Teflon spray (no grease) on the wheels and bearings of the rollers. Oil all hinges including the hinge pin with light weight lubricating oil or Teflon spray.
 5. As with any painted surface exposed to corrosive environments, every 6 months apply a wax to the outside of the painted panel and painted track. If the system includes corner connections make sure the wax penetrates the connection joints.
- a. After washing, the surface should be rinsed thoroughly with clean water and allowed to dry.
 - b. For cleaning, do not use abrasive household cleaners or materials like steel wool or hard brushes that can wear and harm finishes.
 - c. Any glass cleaner used should not be allowed to run down on any other surface.

GLASS INSTALLATION AND GLAZING

This section applies only if you need to install glass for any reason or if glass setting blocks need to be adjusted. Proper glass installation is critical, as, with the NanaWall folding system, glass is a structural part of the panel.

Glass stops and glazing gasket are to be used for “dry” glazing of each panel. Also needed are setting blocks. Use glass setting blocks with varying thickness made from hard plastic. Rubber setting blocks are not acceptable. Width of setting blocks should be at least 1/8" wider than the glass thickness and 1/16" to 1/8" less than the width of the glazing pocket.

Glass, with appropriate dimensions, thickness and specifications will be needed. Depending on the model, widths of all glass panels may not be equal. Please note that glass is required to be fully tempered unless the unit is a window placed above a certain height from the floor. Check with all applicable codes and regulations.

Float glass, including the glass components of insulated glass, shall meet the current requirements of ASTM C 1306 “Standard Specifications for Flat Glass” for quality, thickness and dimensional tolerances. Tempered float glass shall meet the current requirements of ASTM C 1048 “Standard Specifications for Heat-Treated Flat Glass - Kind HS, Kind FT Coated and Uncoated Glass.” All tempered glass shall have a permanent logo, which signifies Safety Commission 16 CFR-1201 and the safety glass test requirements of ANSI Z 97.1 (current editions). Insulating Glass shall meet the requirements of ASTM E 774, Class A, B or C.

Although glass installation with the “dry” glazing system is relatively straight forward, it is recommended that an experienced glazing contractor be used.

It is **very important** that the bracing direction and placement of glass setting blocks on opposite diagonal corners be correct. Setting blocks are to be placed only at opposite diagonal corners with corners alternating with each succeeding panel. This is necessary for the stability and balance of the panels when in operation. If not correctly braced, the unit will not operate properly.

The general rules for bracing are as follows:

- For a panel attached to a side jamb, the lower brace should be at the lower corner closest to the side.
- For a panel with a running carriage, the lower brace should be on the lower corner that is on the same side as the running carriage.
- For a swing panel, the lower brace should be at the lower corner away from the stile with the locking hardware. See Diagram 1 for an example of setting block locations.

Follow all proper applicable glass installation and glazing techniques as recommended in the Flat Glass Marketing Association (FGMA) “Glazing Manual” and “Sealant Manual”. Always use suction cups to shift glass within an opening. It would be best to install the glass on the panels before they are installed in the opening. Panels can be laid flat on sawhorses. If the panels are already installed, they can still be glazed.

1. Close all panels and secure them with the multiple point lock bolts. Start with a panel that is attached to a side jamb or, in the case of unhinged pairs, closest to a side jamb.
2. Remove all glass stops on the panel. Be sure to protect the finish.

3. Measure both the vertical and horizontal dimensions of the glass and the panel opening. Subtract the vertical glass size from the vertical panel opening size. Divide the difference by two. This will give the nominal thickness of the setting block to use at the top and bottom rails. Several setting blocks of different thickness may need to be combined to obtain the desired thickness. Do the same for the horizontal dimension to obtain the thickness of the setting block to use at the stiles.
4. Place a setting block (or combination of setting blocks with desired thickness) on the bottom rail of the panel opening such that it is about 2" from the bottom corner as determined by the bracing rules above.
5. Carefully place the glass in the opening, making sure it rests on the setting block. With insulated glass, make sure that both inner and outer panes are supported evenly.
6. Place a second setting block in the same corner as the first setting block, but in the vertical direction along the stile such that it is about 2" above the corner.
7. Place another setting block in the upper diagonal corner vertically on the opposite stile in the same manner. If necessary, apply a little adhesive that is non-damaging to the glass edge seals such as Dow Corning 791 silicone, to keep the vertical setting blocks from slipping.
8. Place the last setting block on the upper rail on the same corner as the other upper setting block. To get

a proper fit, shift the glass weight by lifting the panel up with a plastic pry bar at the lower corner below the upper setting block. These setting blocks should all fit snugly but should not be forced. Adjust the thickness of the glass setting blocks such that the panel is slightly out of square. The upper corner with the setting blocks should be about 1/16" higher than the other corner.

If the panels are large, additional setting blocks may be needed midpoint on the stiles, especially on a swing panel.

9. For aluminum systems insert the glass stops so that they snap into the panel profile. For wood systems insert the glass stop firmly into position, so they are flush with the panel. Nail to the inner side of the panel with small finish nails. Start with the top and bottom stops and then the sides.
10. Insert the glazing gasket in the space between the glass and the glass stop. First, cut the gasket to a length a little longer than the actual length of the glass stop because gasket material may shrink at low temperatures. Do not stretch or pull the gasket in any manner. If necessary, use soapy water to lubricate the gasket to make insertion easier.
11. Make sure that the stops are locked firmly and securely into position and are flush with the rest of the panel profile.
12. Repeat Steps 2 to 12 for each of the other panels. Setting blocks for each succeeding panel must be placed at diagonally opposite corners in the proper sequence as set forth in Step 1. See Diagram 1 for an example of a three panel unit.

13. After installing the panels, assuming that the head jamb and sill are level, check to see if the gap between the panel and head jamb and panel and sill is even across the width of the panel. With the glass weight, the out of square panels should become almost even. If they remain slightly higher in the upper corner with the setting blocks it is okay. If not, then the lower and upper setting blocks thickness need to be adjusted. Panels have to be braced correctly for proper operation.

DIAGRAM 1:

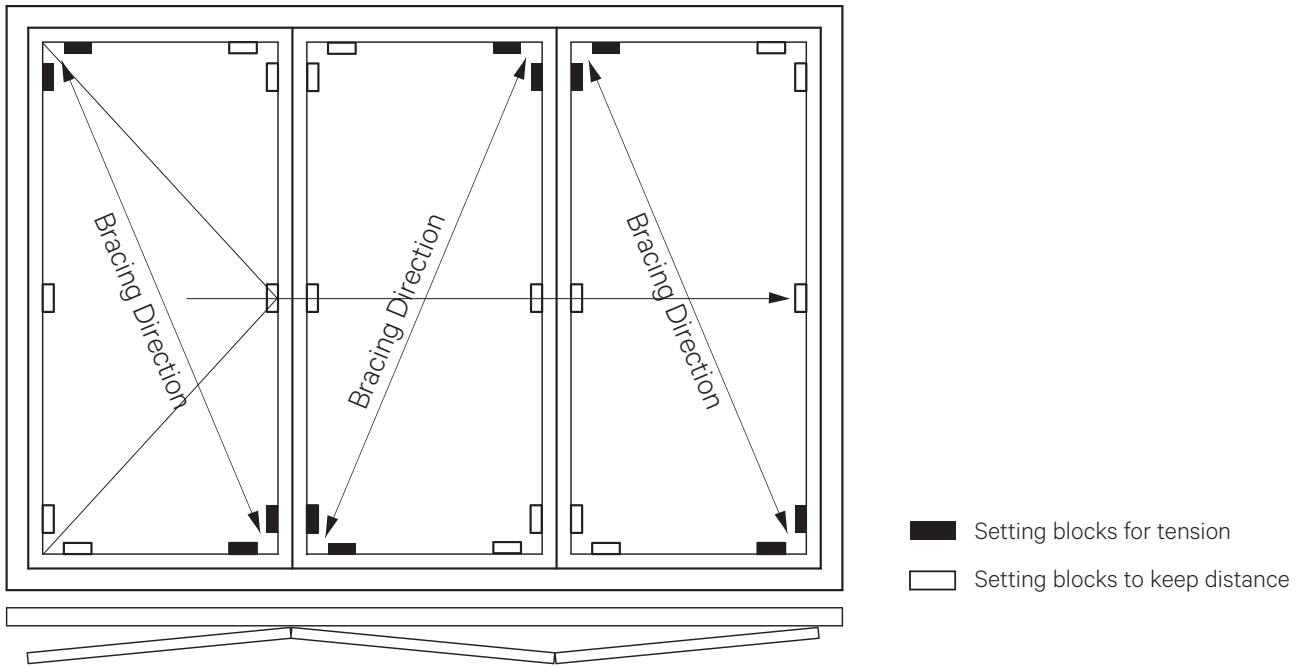

NanaWall Limited Warranty

NanaWall is pleased to provide the following warranty to the owner of NanaWall products, including the initial purchaser and all subsequent owners (“Owner”), subject to all terms and conditions stated herein. This Warranty supersedes all previous product warranties and is the exclusive statement of all commitments and rights of NanaWall with respect to its products sold on or after May 1, 2023, to be installed in the United States (excluding territories) or Canada.

NanaWall shall have no obligation to respond under this Warranty until receipt of proper notice of a claim and an opportunity to respond. Upon notice and confirmation by NanaWall of a condition covered under this Warranty, NanaWall will respond in good faith and in a timely manner as follows:

TEN YEAR COVERAGE.

For ten (10) years from the date of delivery by NanaWall (“Delivery”), NanaWall will respond as follows:

Insulated Glass. For an insulated glass unit with a permanent material obstruction of vision due to a premature failure of the glass seal, NanaWall will ship a replacement glass unit or panel.

Exception: insulated glass units for cero® are covered for five (5) years from Delivery.

Powder Coat or Baked-on Fluoropolymer Surface Finish of Aluminum Profiles. For powder coat or baked-on fluoropolymer surface finish not functioning as an Effective Surface Material (“ESM”*), NanaWall will, at its option, (1) assume reasonable costs to restore the finish using standard commercial refinishing techniques or (2) ship replacement parts. Uneven fading is not a covered condition due to environmental variables.

Exception: Products installed within two (2) miles of any coastal area or body of salt water or other harsh or corrosive environments or chemicals (“Harsh Environments”) are covered for one (1) year from Delivery, provided that the instructions in Specific Suggested Maintenance For Coastal Salt Water and Other Extreme Environments included in the Owner’s Manual for each Product and is available for review on NanaWall’s website, is properly implemented and documented.

**An ESM is a finish without (1) substantial cracking, chipping, or peeling due to the deterioration of the finish (exclusive of mechanical damage); (2) chalking in excess of a numerical rating of 8 as per ASTM D 659; or (3) fading or color changes in excess of 5 NBS units as per ASTM D 2244.*

Rollers. For a roller with material or workmanship issues that significantly impair proper operation and function, NanaWall will ship a replacement roller.

Wood and Other Remaining Components (for product installed by an independent NanaWall Certified Installer or Approved Installer*). For all remaining components of NanaWall products not otherwise addressed herein with a material or workmanship issue that substantially impairs operation and function, NanaWall will, at its option, (1) ship a replacement part or product or (2) ship any replacement part or replacement product in the same stage of fitting and/or finishing as originally supplied by NanaWall. This includes wood frame components, hinges, handles, locking mechanisms, tracks, beads, and weather-stripping.

FIVE YEAR COVERAGE.

For five (5) years from Delivery, NanaWall will respond as follows:

Laminated Glass. For a laminated glass unit with permanent material obstruction of vision due to premature delamination, NanaWall will ship a replacement glass unit or panel.

Wood and Other Remaining Components (for product NOT installed by an independent NanaWall Certified Installer or Approved Installer*). For all remaining components of NanaWall products not otherwise addressed herein with a material or workmanship issue that substantially impairs operation and function, NanaWall will ship a replacement part or product without charge in the same stage of fitting and/or finishing as originally supplied by NanaWall. This includes wood frame components, hinges, handles, locking mechanisms, tracks, and weather-stripping.

THREE YEAR COVERAGE.

For three (3) years from Delivery, NanaWall will respond as follows:

Anodized Surface Finish of Aluminum Profiles. For anodized surface finish of aluminum profile not functioning as an ESM,* NanaWall will, at its option, (1) assume reasonable costs to restore the finish on a non-compliant (non-ESM) material using standard commercial refinishing techniques or (2) ship replacement parts.

Exception: Products installed in Harsh Environments are not covered.

ONE YEAR COVERAGE.

For one (1) year from Delivery, NanaWall will respond as follows:

Screens. For a screen part (excluding the screen mesh) with a material or workmanship issue that substantially impairs the function of the screen, NanaWall will, at its option, (1) ship a replacement screen or (2) upon return by owner, repair the screen without charge.

ADDITIONAL SERVICE INFORMATION

This Warranty does not cover labor costs to remove existing parts or products, install a replacement part or product, costs to finish wood products, or the cost to repair or replace surrounding substrates, trim, or other work. Nor does it cover costs incurred due to delays or other construction costs, costs for late or damaged delivery, loss of revenue, loss of time, liquidated damages, inconvenience, or loss of use of the product or any parts or components. NanaWall reserves the right to determine whether or not a covered condition exists. If the claim is not covered under this Warranty, NanaWall may charge and collect a fee for on-site product inspections.

Any replacement part or product will be shipped to the location of original product delivery by NanaWall. Replacement products will be the closest equivalent current product and may not be an exact match to the original. Any replacement parts or any repairs are warranted for the remainder of the original limited warranty period. If providing a replacement part or product is not commercially practicable, NanaWall may elect to refund the purchase price of the affected product in full satisfaction of its obligations.

Wood. Wood components must be properly finished on all sides promptly after receipt of unit, before installation, and prior to exposure to weather. Repair or replacement of a warped wood panel or frame can be delayed by up to 12 months from date of claim to allow the wood component to adjust to local environmental conditions.

Glass. Unloading the replacement glass/panel from the delivery truck is the responsibility of the owner. Due to the weight of the product, appropriate manpower and/or equipment will be needed to unload and move the glass/panel to the location for replacement. Depending on the size of the replacement part and interior building dimensions, it may not be possible to transport the glass/panel through the interior of the building. NanaWall is not responsible for any costs associated with moving the replacement glass/panel at the delivery location.

**Whether an installer is a NanaWall Certified Installer or Approved Installer is determined by the installer's status as of the date of delivery. NanaWall maintains information regarding the installers designated as Certified Installers or Approved Installers.*

NOTICE PROCESS

Written notice of any claim under this Warranty with supporting documents such as photos or videos must be given to Nana Wall Systems, Inc. via email to service@nanawall.com or via mail to 100 Meadowcreek Drive, Corte Madera, CA 94925, promptly when discovered. A condition will not be covered under this Warranty if there is a failure to notify NanaWall in writing (1) within 7 days of receipt of the product for any defect which an ordinary inspection would reveal, (2) within a reasonable time during the warranty period after an impairment in operation and use is manifest or a hidden defect is discovered, or (3) for claims first made after expiration of the coverage period outlined in this Warranty.

DISCLAIMERS & LIMITATIONS

Any responsibility of NanaWall is contingent upon owner fulfilling its notice obligations as stated in this Warranty. The owner shall have no standing to assert a claim absent timely notice to NanaWall and an opportunity to cure. The remedies prescribed in this Warranty are the exclusive and sole remedies available to the owner who hereby waives any claim not encompassed herein. This exclusivity and waiver survive expiration of warranty coverages herein. In no event shall the liability of NanaWall or any seller of NanaWall product exceed the price paid for the product.

This Warranty is the sole and exclusive warranty for NanaWall products. **ALL OTHER WARRANTIES, EXPRESS OR IMPLIED, INCLUDING ANY WARRANTY OF MERCHANTABILITY OR FITNESS FOR A PARTICULAR PURPOSE, ARE DISCLAIMED. NANAWALL SHALL NOT BE LIABLE FOR CONSEQUENTIAL OR INCIDENTAL DAMAGES.** Some state and federal laws may not allow disclaimers of implied warranties or exclusions of incidental or consequential damages, so these limitations or exclusions may not apply to you. Where federal law prohibits disclaimer of implied warranties, the duration of any implied warranty is limited to the duration of the relevant coverage period, if less than the statutory limitation period. This Warranty gives you specific legal rights, and you may also have other rights which vary from state to state.

This Warranty may only be modified by a writing signed by an officer of NanaWall. Any action taken by NanaWall does not create a new warranty or extend the duration of the original product warranty. A failure by NanaWall to enforce a warranty provision shall not constitute a waiver barring subsequent enforcement.

EXCLUDED CONDITIONS.

This Warranty does not cover the following conditions, or any damage or issues caused in whole or part by the following:

- Improper product selection, application, storage, handling, modification, or waterproofing; Movement of surrounding substrates, including deflection of the header of more than ¼", or any other stresses on product; Improper installation, flashing, or integration into the structure; Failure to provide an adequate overhang; Failure to prevent the effects of sheeting rain or water; Failure to install proper weep holes in sill where needed, and failure to properly drain water exiting weep holes in the sill; Failure to meet code or specification requirements.
- Finishing by anyone other than NanaWall, including, but not limited to, not properly finishing all sides of wood products promptly after receipt of unit, before installation, and before exposure to weather, finishing exterior wood in dark colors, or not refinishing periodically; Discoloration of finish; Failure to immediately repair any breaches such as scratches, chips, or abrasions in any finish or aluminum profile.
- Condensation, frost, or mold caused by high interior relative humidity; Installation near swimming pools, saunas, hot tubs or other high humidity environments or sources of chlorine; Harsh chemicals such as road salt, solvents, acid, brick or mortar wash, or cleaning chemicals; Corrosion, oxidation, discoloration or tarnish on product installed in Harsh Environments.
- Normal weathering, wear and tear; Failure to follow the NanaWall operation and maintenance instructions; Failure to operate the product for more than one month; Failure to clean and maintain aluminum surfaces in accordance with AAMA 609 and 610 or not maintaining adequate cleaning records.
- Imperfections in glass that do not affect the product's structural integrity or obscure vision and cannot be detected from within 10 feet as per ASTM C 1036; Accidental or spontaneous glass breakage; Glass breakage due to thermal or other stresses, or glass with film or other coatings applied to the surface; Industry accepted bow, warp or distortion in glass and minor variations in glass color; Glass not installed as per NanaWall's instructions.

- Variations in wood grain or color; Warp within the allowable warp tolerance for wood panels per ANSI/WDMA I.S. 6-A-01; Warp that does not affect the normal functioning of the Product; Warpage on wood panels caused by leaving panels in the open position exposed to the elements or not engaging the locking points properly when in the closed position; Resin or sap bleeding from wood panels.
- Panel shrinkage or expansion caused by change in weather; Expansion or bowing of aluminum units caused by exposure to sunlight or caused by temperature difference between interior and exterior panel surfaces.
- Acts of God, falling objects, fire, accidents, external forces, extreme weather events, or other conditions beyond NanaWall's control.
- Gas fill or retention levels in insulated glass units.
- Field testing of Product; Performance of the Product in conformance to any published NanaWall testing results (e.g. air infiltration, water infiltration, structural loading, thermal and sound). Published test results measure the laboratory performance of a single sample of the product of a certain size, sill and configuration that may not be applicable to the Product being field tested. Performance during testing may vary depending upon handling, installation, use, maintenance, and time after installation. Field testing must be in compliance with AAMA 502, including water penetration testing at 2/3 of the pressure of applicable published test results.
- Products or components not supplied by NanaWall; Products that have not been paid for in full; Products ordered in larger sizes or special configurations beyond NanaWall's published specifications. Product with glass that is heavier than NanaWall specifications; Product that has been modified or altered in any manner.

NanaWall Warranty Registration

Must be filled out and returned to Nana Wall Systems, Inc., 100 Meadowcreek Drive, Corte Madera, CA 94925 within 30 days from date of purchase of the NanaWall in order for the limited warranty to become effective.

NANAWALL ORDER # _____

PROJECT NAME _____

Date of Purchase _____

Purchaser Name _____

PROPERTY OWNER

Name _____

Address _____

Telephone _____

E-mail _____

Project Address (if different from above) _____

INSTALLATION

Installer Name _____

Address _____

Telephone _____

E-mail _____

Type of project new residential restaurant shopping mall
 residential remodel office building other _____

Architect Name _____

Address _____

1. Is the installation complete? yes If yes, date completed _____

no If no, date scheduled _____

2. Have you been shown how to yes Is operation satisfying? yes no

operate your new NanaWall? no If no, why not? _____

Print Name _____

Signature _____

Date _____